

1

General information

Introduction

The 4012 and 4016 diesel engines are a family of 12 and 16 cylinder turbocharged diesel engines, designed by Perkins Engines Company Limited, Stafford, a world leader in the design and manufacture of high-performance diesel engines. They form part of the 4000 Series range of engines.

Perkins approved assembly and quality standards, together with the latest technology, have been applied to the manufacture of your engine to give you reliable and economic power.

Read and remember the ["Safety precautions" on page 2](#). They are given for your protection and must be observed at all times.

To ensure that you use the correct information for your specific engine type, refer to ["Engine identification" on page 11](#).

Note: The terms 'left side' and 'right side' apply when the engine is viewed from the flywheel end.

Special tools are required to perform certain operations. A list of those required for the operations described in this handbook is given in ["Service tools" on page 9](#). Reference to the relevant special tools is also made at the beginning of each operation, along with those which are universally available (UA) and any additional specialist supplied equipment (SP) required.

Danger is indicated in the text by two methods:

Warning! *This indicates that there is a possible danger to the person.*

Caution: *This indicates that there is a possible danger to the engine.*

Note: Is used where the information is important, but there is not a danger.

Safety precautions

General

For safe and reliable operation of the engine it is very important that these safety precautions, and those **Warnings** and **Cautions** given throughout this handbook, are observed, and where necessary the special tools indicated are used.

All safety precautions should be read and understood before operating or servicing the engine.

Improper operation or maintenance procedures are dangerous and could result in accidents, injury or death.

The operator should check before beginning an operation that all the basic safety precautions have been carried out to prevent accidents occurring.

You must also refer to the local regulations in the country of use.

Note: Some items only apply to specific applications.

Guards

- Ensure that guards are fitted over exposed rotating parts, hot surfaces, air intakes, belts or live electrical terminals (high and low tension).

Protection equipment

- Ensure that correct protection equipment is worn at all times.
- Always wear protective gloves when using inhibitors or anti-freeze, removing the pressure cap from the radiator or heat exchanger filler, changing the lubricating oil/filter or changing the electrolyte in the battery.
- Always wear ear protection when working in an enclosed engine room.
- Always wear suitable eye protection when using an air pressure line.
- Always wear protective boots when working on the engine.
- Always wear protective headgear when working on or underneath the engine.

Naked flames

- Ensure that no smoking or naked flames are lit when checking battery electrolyte, working in the engine room or when operating or servicing the engine.

Fuel/oil pipes

- Ensure that all pipes are regularly checked for leaks.
- Ensure that all pipes and the surrounding area are regularly checked for spilt oil (and cleaned up where necessary).
- Always apply suitable barrier cream to hands before any work is carried out.

Shutdown equipment

- Always test that the protection system is working correctly.
- When stopping the engine in case of overspeed, high water temperature or low oil pressure should be provided.
- For heat sensors, methane and smoke protectors should be provided (if applicable).
- Always be in a position to stop the engine (even remotely).

Start-up

- When working on the engine always ensure that the battery has been disconnected, and that any other means of accidental start-up has been disabled.
- Never start the engine with the governor linkage disconnected.
- Do not hold the stop lever in the run position when starting the engine.
- Always hold the stop lever in the stop position when cranking only.

Electrical equipment

- Always check that electrics are earthed to local safety standards.
- Always disconnect the electrical supply to the jacket water heater (if fitted) before working on the engine.
- Take care to prevent any danger of electric shock.
- Never re-adjust the settings of electronic equipment without reference to the Workshop Manual.

Freezing or heating components

- Always use heat resistant gloves and use the correct handling equipment.

Exhaust system

- Check the system for leaks.
- Ensure that the engine room is correctly ventilated.
- Check that all the guards are fitted.
- Check that the pipework allows the exhaust gas to escape upwards.
- Check that the pipework is supported.

Stopping the engine

1 Disengage the engine load.

2 Run the engine on NO LOAD for 5 to 7 minutes before stopping.

Note: This will allow the circulating lubricating oil to dissipate heat from the bearings, pistons, etc. It will also allow the turbochargers, which run at a very high speed, to slow down while there is still oil flow through the bearings.

Ensure that the engine is stopped before performing any of the following operations:

- Changing the lubricating oil.
- Filling or topping up the cooling system.
- Beginning any repair work on the engine.
- Adjusting belts (where fitted).
- Adjusting bridge pieces / valve clearance.
- Changing spark plugs.
- Changing air or oil filters.
- Tightening any fixing bolts.

Flammable fluids

- Ensure that these are never stored near the engine.
- Ensure that they are never used near a naked light.

Clothing

- Do not wear loose clothing, ties, jewellery, etc.
- Always wear steel toe cap shoes/boots.
- Always wear the correct head, eye and ear protection.
- Always wear suitable overalls.
- Always replace a spillage contaminated overall immediately.

Lifting heavy components

- Always use the correct lifting equipment.
- Never work alone.
- Always wear a helmet, if the weight is above head height.

De-scaling solution

- Always wear both hand and eye protection when handling.
- Always wear overalls and correct footwear.

Waste disposal

- Do not leave oil covered cloths on or near the engine.
- Do not leave loose items on or near the engine.
- Always provide a fireproof container for oil contaminated cloths.

Note: Most accidents are caused by failure to observe basic safety precautions and can be prevented by recognising potentially dangerous situations before an accident occurs. While there are many potential hazards that can occur during the operation of the engine which cannot be always be anticipated, and thus a warning cannot be included to cover every possible circumstance that might involve a potential hazard, by following these basic principles the danger can be minimised.

How to care for your engine

This handbook has been written to assist you to maintain and operate your engine correctly, and to carry out routine servicing of the engine.

The instructions contained in this handbook will, provided that they are correctly carried out, ensure the safe operation of the equipment.

Before undertaking any work on the engine the relevant chapter in the Workshop Manual should be read and fully understood.

The information contained within this handbook is based on such information as was available at the time of print. In line with Perkins Engines Company Limited, Stafford policy of continual development and improvement that information may change at any time without notice. The engine user should therefore ensure that he has the latest information before starting work.

Users are respectfully advised that it is their responsibility to employ competent persons to operate the equipment in the interest of safety.

Operators who are not equipped to undertake major repairs are urged to consult their Perkins distributor.

When not working on the engine, ensure that all covers, blank flanges, doors, etc., are refitted to openings to prevent the ingress of dirt, etc.

Please quote the engine type and serial number with all your enquiries, see ["Engine identification" on page 11](#).

If any doubt exists regarding the installation, use or application of the engine, the Installation Manual should be consulted. For further advice contact the Applications Department at Perkins Engines Company Limited, Stafford.

To obtain the best performance and the longest life from your engine, you must ensure that the maintenance operations are done at the intervals indicated. Refer to ["Service schedule \(prime and baseload rated engines\)" on page 34](#) or ["Service schedule \(stand-by duty engines\)" on page 37](#). If the engine works in a very dusty environment or other adverse conditions, certain maintenance intervals will have to be reduced.

Oil change intervals may be changed according to operating experience by agreement with Perkins Engines Company Limited, Stafford and subject to oil analysis being carried out at regular intervals.

Ensure that all adjustments and repairs are done by personnel who have had the correct training. Perkins distributors have this type of personnel available. You can also obtain parts and service from your Perkins distributor.

Dangers from used engine oils

Prolonged and repeated contact with mineral oil will result in the removal of natural oils from the skin, leading to dryness, irritation and dermatitis. The oil also contains potentially harmful contaminants which may result in skin cancer.

A suitable means of skin protection and washing facilities should be readily available.

The following is a list of 'Health Protection Precautions', suggested to minimise the danger of contamination.

- 1 Prevent prolonged and repeated contact with used engine oils.
- 2 Wear protective clothing, including impervious gloves where applicable.
- 3 Do not put oily rags into pockets.
- 4 Prevent contaminating clothes, particularly underwear, with oil.
- 5 Overalls must be cleaned regularly. Discard unwashable clothing and oil impregnated footwear.
- 6 First aid treatment should be obtained immediately for open cuts and wounds.
- 7 Apply barrier creams before each period of work to aid the removal of mineral oil from the skin.
- 8 Wash with soap and hot water, or alternatively use a skin cleanser and a nail brush, to ensure that all oil is removed from the skin. Preparations containing lanolin will help replace the natural skin oils which have been removed.
- 9 Do NOT use petrol, kerosene, diesel fuel, thinners or solvents for washing the skin.
- 10 If skin disorder appears, medical advice must be taken.
- 11 Degrease components before handling if practicable.
- 12 Where there is the possibility of eye damage, suitable eye protection or a face shield should be worn. An eye wash facility should be readily available.

Environmental protection

There is legislation to protect the environment from the incorrect disposal of used lubricating oil. To ensure that the environment is protected, consult your Local Authority who can give advice.

Danger from 'fluorosilicone' (Viton) 'O' ring seals

All of the engines 'O' ring seals are made from fluorosilicone material.

It is a safe material under normal conditions of operation, but if it is burned the extremely dangerous hydrofluoric acid is produced.

If it is necessary to come into contact with components which have been burnt, follow the precautions below:

- Allow the components to cool.
- Use Neoprene gloves and a face mask.
- Wash the contaminated area with a calcium hydroxide solution and then with clean water.
- Disposal of gloves and components which are contaminated must be in accordance with local regulations.

Caution: *If there is contamination of the skin or eyes, wash the affected area with a continuous supply of clean water. Obtain immediate medical attention.*

Practical information for cleaning components

Use suitable gloves for protection when components are degreased.

Keep the work area clean and ensure that components are protected from dirt and debris. Ensure that dirt does not contaminate the fuel system.

Before a component is removed from the engine, clean around the component and ensure that all openings, disconnected hoses and pipes are sealed.

Remove, clean and inspect each component carefully. If it useable, put it in a clean dry place until needed. Ball and roller bearings must be cleaned thoroughly and inspected. If the bearings are usable, they must be flushed in low viscosity oil and protected with clean paper until needed.

Before the components are assembled, ensure that the area is free from dust and dirt as possible. Inspect each component immediately before it is fitted, wash all pipes and ports, and pass dry compressed air through them before connections are made.

Engine preservation

Ex-works preservation treatment

The preservation treatment will give up to 12 months shipping and storage protection under normal enclosed storage conditions of -15 °C to +55 °C and up to 90% relative humidity.

- 1 The oil used on engine test will give protection for up to 12 months after despatch from the works.
- 2 After test the oil is then drained from the sump.
- 3 The corrosion inhibited anti-freeze at 50% dilution with clean water used on engine test will give protection for up to 12 months after despatch from the works.
- 4 After spray painting, all openings in the engine (including points where pipework has been removed and air cleaner inlets, etc.), are sealed with plastic plugs or covers.
- 5 The drive face of the flywheel is coated with Valvoline Tectyl 506 preservative.

Parts and service

Service literature

Workshop manuals, installation drawings and other service publications are available from your Perkins distributor.

Training

Local training for the correct operation, service and overhaul of engines is available at certain Perkins distributors. If special training is necessary, your Perkins distributor can advise you how to obtain it at the Perkins Customer Training Department or other main centres.

Service Bulletins

Service procedures and engine design are checked continuously at Perkins Engines. As a result of this development work, it may become necessary to alter the information in manuals and other service publications.

Between revisions of the literature, all relevant personnel are provided with full details of changes as they occur. The information is produced as a Service Bulletin; these are supplied to distributors for distribution as necessary.

Service tools

The tools and equipment which follow are required for the operations described in this handbook.

Universally available tools

Description	Qty
Screwdriver (bridge piece and valve clearance adjustment)	1
17 mm Combination spanner (bridge piece adjuster locknut)	1
19 mm Combination spanner (rocker adjuster locknut)	1
Feeler gauge set (to set bridge piece and valve clearance)	1
Strap wrench (oil filter removal)	1
30 mm combination spanner (sump drain)	1
Tool box	1

Perkins supplied tools

Part No	Description	Qty
T6253/312	Valve and seat recession tool	1
SE253	Engine cranking device	1

Description of 4012 series engine models

Reference Code	Description
4012TWG	12 cylinder "V" form diesel engine, water cooled, turbocharged (twin turbochargers), jacket water cooled charge air coolers. Oil coolers in engine cooling circuit. Horizontal air cleaners.
4012TWG2	Upated version of the 4012TWG. 12 cylinder "V" form diesel engine, water cooled, turbocharged (twin turbochargers), jacket water cooled charge air coolers. Oil coolers in engine cooling circuit. Horizontal air cleaners.
4012TAG	12 cylinder "V" form diesel engine, water cooled, turbocharged (twin turbochargers), air cooled charge air intercooler in radiator. Oil coolers in engine cooling circuit. Horizontal air cleaners.
4012TAG1	Upated version of the 4012TAG. 12 cylinder "V" form diesel engine, water cooled, turbocharged (twin turbochargers) air cooled charge air intercooler in radiator. Oil coolers in engine cooling circuit. Horizontal air cleaners.
4012TAG2	Upated version of the 4012TAG1. 12 cylinder "V" form diesel engine, water cooled, turbocharged (twin turbochargers), air cooled charge air intercooler in radiator. Oil coolers in engine cooling circuit. Horizontal air cleaners.
4012TEG	12 cylinder "V" form diesel engine, water cooled, turbocharged (twin turbochargers), raw water cooled charge air coolers with separate water pump and cooling circuit. Oil coolers in engine cooling circuit. Horizontal air cleaners.
4012TEG2	Upated version of the 4012TEG. 12 cylinder "V" form diesel engine, water cooled, turbocharged (twin turbochargers), raw water cooled charge air coolers with separate water pump and cooling circuit. Oil coolers in engine cooling circuit. Horizontal air cleaners.

Description of 4016 series engine models

Reference Code	Description
4016TWG	16 cylinder "V" form diesel engine, water cooled, turbocharged (four turbochargers), jacket water cooled air charge coolers. Oil coolers in engine cooling circuit. Horizontal air cleaners.
4016TWG2	Upated version of the 4016TWG. 16 cylinder "V" form diesel engine, water cooled, turbocharged (four turbochargers), jacket water cooled charge air coolers. Oil coolers in engine cooling circuit. Horizontal air cleaners.
4016TAG	16 cylinder "V" form diesel engine, water cooled, turbocharged (twin turbochargers), air cooled charge air intercooler in radiator. Oil coolers in engine cooling circuit. Horizontal air cleaners.
4016TAG1	Upated version of the 4016TAG. 16 cylinder "V" form diesel engine, water cooled, turbocharged (four turbochargers) air cooled charge air intercooler in radiator. Oil coolers in engine cooling circuit. Horizontal air cleaners.
4016TAG2	Upated version of the 4016TAG1. 16 cylinder "V" form diesel engine, water cooled, turbocharged (four turbochargers) air cooled charge air intercooler in radiator. Oil coolers in engine cooling circuit. Horizontal air cleaners.
4016TEG	16 cylinder "V" form diesel engine, water cooled, turbocharged (twin turbochargers), raw water cooled charge air coolers with separate water pump and cooling circuit. Oil coolers in engine cooling circuit. Horizontal air cleaners.
4016TEG1 and 4016TEG2	Upated versions of the 4016TEG. 16 cylinder "V" form diesel engine, water cooled, turbocharged (four turbochargers), raw water cooled charge air coolers with separate pump and cooling circuit. Oil cooler in engine cooling circuit. Horizontal air cleaners.

Engine identification

The engine number and its build specification details are given on the date plate, fixed to the crankcase above the flywheel housing on 'A' bank (A1).

Notes:

- On engines built before January 2000, the engine number is stamped on the face of the crankcase 'A' bank, above the flywheel housing (A2).
- On engines built from February 2000, the engine number is stamped on the face of the crankcase 'B' bank, above the gearcase (A3).

For reference codes and engine description refer to ["Description of 4012 series engine models" on page 10](#) and ["Description of 4016 series engine models" on page 10](#).

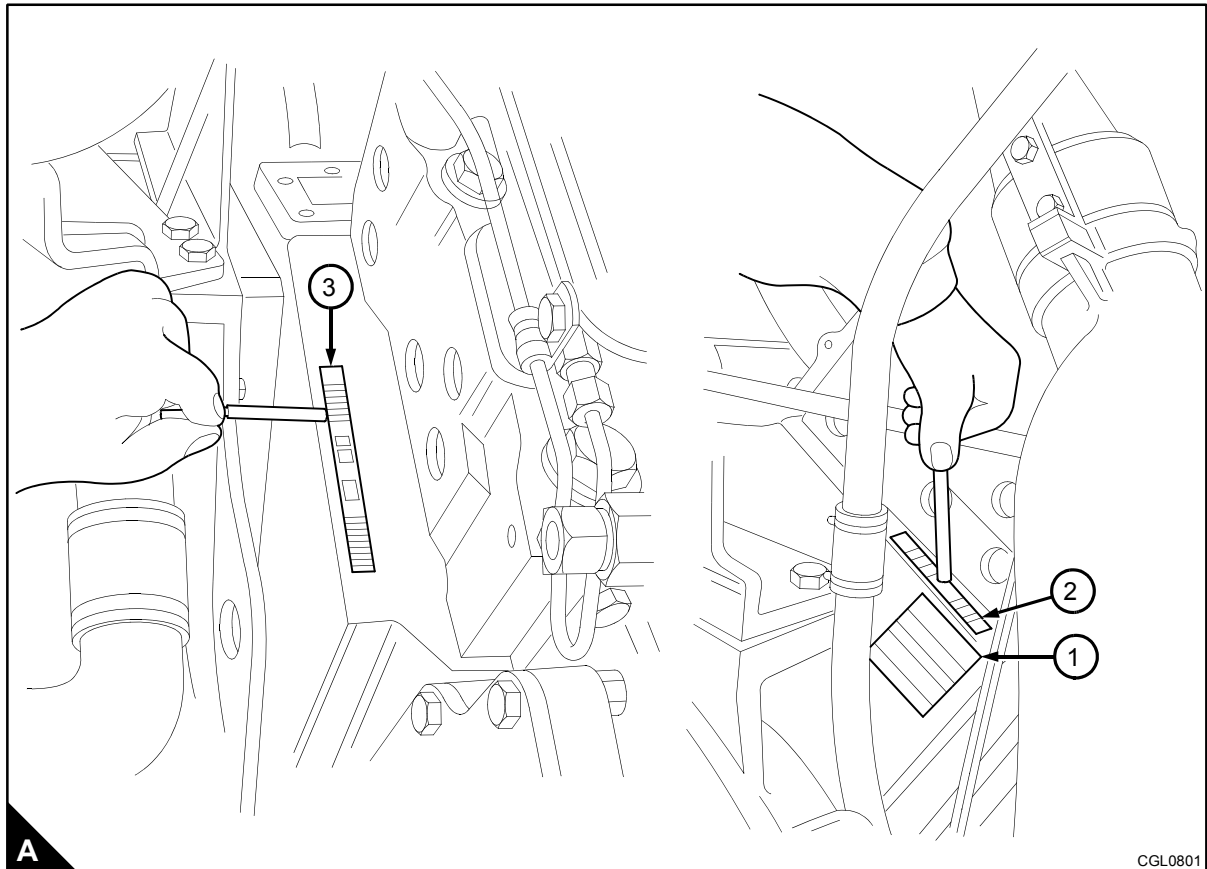

Engine specifications

The figures quoted are based on engines set to meet the requirements of ISO 8528. For full technical data please refer to the appropriate Technical Data sheet.

General engine data

Engine model	4012	4016
Cycle	4 stroke	4 stroke
No. of cylinders	12	16
Configuration	V-form	V-form
Bore	160 mm	160 mm
Stroke	190 mm	190 mm
Total swept volume	45,84 litres	61,123 litres
Compression ratio	13,6:1	13,6:1
Rotation	Anti-clockwise looking on flywheel end	
Firing order	1A-6B-5A-2B-3A-4B-6A-1B-2A-5B-4A-3B	1A-1B-3A-3B-7A-7B-5A-5B-8A-8B-6A-6B-2A-2B-4A-4B
Valve timing	inlet valve opens 60° BTDC	exhaust valve opens 46° BBDC
	inlet valve closes 46° ABDC	exhaust valve closes 60° ATDC
Cylinder numbering	Cylinder 1 furthest from flywheel	
Cylinders designated A are on the left hand side of the engine, when viewed from the front crankshaft damper end and cylinders designated B are on the right hand side of the engine.		
Valve clearances (engine cold)	exhaust	0,40 mm (0,016")
	inlet	0,40 mm (0,016")
Valve diameter (mm) inlet and exhaust	48	48
	(52 on 4012TAG1/2 AND 4016TAG1/2)	
Injection timing	See engine data plate	
Piston speeds	Engine rev/min	m/s (ft/min)
	1000	6,33 (1247)
	1200	7,60 (1496)
	1500	9,50 (1870)
	1800	11,40 (2244)

Engine weights

Engine model	4012	4016
Dry weight (engine)	4360 kg 4012TAG	5500 kg 4016TAG
	4360 kg 4012TAG1	5750 kg 4016TAG1
	4400 kg 4012TAG2	5750 kg 4016TAG2
	4975 kg 4012TWG	5940 kg 4016TWG/2
	5315 kg 4012TWG2	5820 kg 4016TEG
	4680 kg 4012TEG2	
Dry weight engine & tropical radiator	5280 kg 4012TAG	6900 kg 4016TAG
	5760 kg 4012TAG1	8010 kg 4016TAG1
	5800 kg 4012TAG2	8010 kg 4016TAG2
	4995 kg 4012TWG	
	5315 kg 4012TWG/2	
Dry weight engine & heat exchanger	4860 kg 4012TEG	6000 kg 4016TEG

Cooling system

Engine model	4012			4016		
Approved coolants	See "Coolant specification" on page 60					
Total water capacity	Ltrs	Gals	Spec	Ltrs	Gals	Spec
	200	44	TAG	255	56.1	TAG
	232	51	TAG1	316	70	TAG1
	232	51	TAG2	316	70	TAG2
	185	40	TWG	95	21	TWG ⁽¹⁾
	205	45	TWG2	95	21	TWG2 ⁽¹⁾
	82	18	TEG ⁽²⁾	108	23.7	TEG ⁽²⁾
Maximum radiator top tank temperature	93 °C					
Maximum water temperature into engine	80 °C					
Thermostat opening temperature	71 °C					
System pressure	0,5 to 0,7 bar					

(1) Engine only.

(2) Engine with heat exchanger.

Cooling system heaters

Engine model	4012	4016
Heater	2 x 4 kW	
Voltage	210-250V ac	
Temperature setting	26,7 °C (80 °F)	

Fuel system

Engine model	4012	4016
Approved fuels	See "Fuel specification" on page 57	
Minimum size fuel tank	14000 litres (3000 gal.)	18000 litres (4000 gal.)
Relief valve setting	310 kPA (45 psi)	
Injector nozzle pressure	225-235 atm	
Injection equipment	Lucas-Bryce unit injector	
Filter/water separator	Spin-on disposable canister(s)	
Fuel lift pump	Maximum suction lift 2 metre	
Fuel flow	20,457 litres/min. (4.5 gpm) @ 1800 r/min	

Induction system

Engine model	4012	4016
Air cleaners	Twin horizontal air cleaners	
Type	Paper element	
Air restriction indicator setting	380 mm H ₂ O	
Turbochargers	2 off	4 off

Lubrication system

Engine model	4012	4016
Recommended oil	See "Lubricating oil recommendations" on page 58	
Type of system	Wet sump, external engine mounted oil pump	
Total oil capacity (including cooler and filter)	178 litres (39.2 gal)	238 litres (53 gal)
Sump capacity (dipstick)		
Minimum	136 litres (30 gal)	147 litres (33 gal)
Maximum	159 litres (35 gal)	214 litres (47 gal)
Crankcase pressure (maximum)	25 mm (1") water gauge	
Lubricating oil temperature maximum to bearings	105 °C	
Lubricating oil pressure at 80 °C temp. to bearings	0,34 mPa	
Maximum oil temperature in sump	115 °C	
Minimum oil pressure (1500 rpm) (at filter head)	200 kPa (30 lb/in ²)	
Oil filter	Disposable canister type	
Oil pump location	'A' Bank	

Exhaust system

Engine model	4012	4016
Manifold type	Dry or water cooled	
Exhaust outlet flange	Vertical (twin)	
Mating flange	See Installation Manual	

Flywheel and flywheel housing

Engine model	4012	4016
Flywheel	SAE 18" (SAE 21" Optional)	
Flywheel housing - SAE size	"0"	

Engine fixing bolts

Engine model	4012	4016
Hole dia. (engine feet)	22 mm	
No. off	8	
Hole dia. (radiator feet)	18 mm x 6 4012TAG	22 mm x 6 4016TAG/2
Turbochargers	22 mm x 6 4012TAG2	
	22 mm x 6 4012TWG/1	

Air starter

Engine model	4012	4016
Air starter	See Installation Manual	
Air starter pressure	150 lb/in ² (10.34 bar)	
Compressed air supply	170 lb/in ² (11.72 bar)	

Instrument panel (engine mounted)

Engine model	Normal Operation
Oil pressure	Between 276-413 kPa (40-60 lb/in ²)
Oil temperature	Between 80-90 °C (176-194 °F)
Water temperature	Between 65-85 °C (149-185 °F)

Protection equipment

Before resetting protection equipment, it must be established whether special settings (for that individual engine) have been specified in the engine sales contract. This is particularly important with **ALL** high water temperature settings, and **ALL** Cogen applications.

Standard settings for protection equipment are specified below.

Shutdown switches	Alarm	Shutdown
High oil temperature	100 °C	105 °C
Low oil pressure	2,06 bar (30 lb/in ²)	1,93 bar (28 lb/in ²)
High water temperature		
71 °C Thermostat	91 °C	96 °C
85 °C Thermostat	96 °C	101 °C
96 °C Thermostat	100 °C	105 °C
Overspeed	15% above max. running speed (Except 1800 r/min which is 7%)	

Caution: The above standard settings do not supersede any settings specified in the engine sales contract.

Electrical system

Engine model	4012	4016
Voltage	24V	
Alternator	Belt driven	
Alternator output	30A	
Starter motor	Twin Prestolite	
No. of teeth (gear ring)	156	
No. of teeth (starter motor)	12	
Battery (lead acid)	24V DC (2 x 12V)	
Battery capacity down to 0 °C (32 °F)	286 Ah	

**4012/16 engine wiring diagram
(twin starters, single start relay and electronic governor)**

Item	Description
A1	Engine fitted terminal box
A2	Starter motor 1
A3	Starter motor 2
A4	Emergency stop
A5	Start inhibit relays
A6	Start relay
A7	Fuel stop solenoids (energised to run)
A8	Magnetic pick-ups
A9	Engine flywheel
A10	Electronic governor control box
A11	Electronic governor actuator
A12	Permanent battery positive supply for engine to run, remove this positive supply to stop
A13	Start engine
A14	Battery positive

Note: The diagram refers to standard engine wiring on engines fitted with a terminal box.

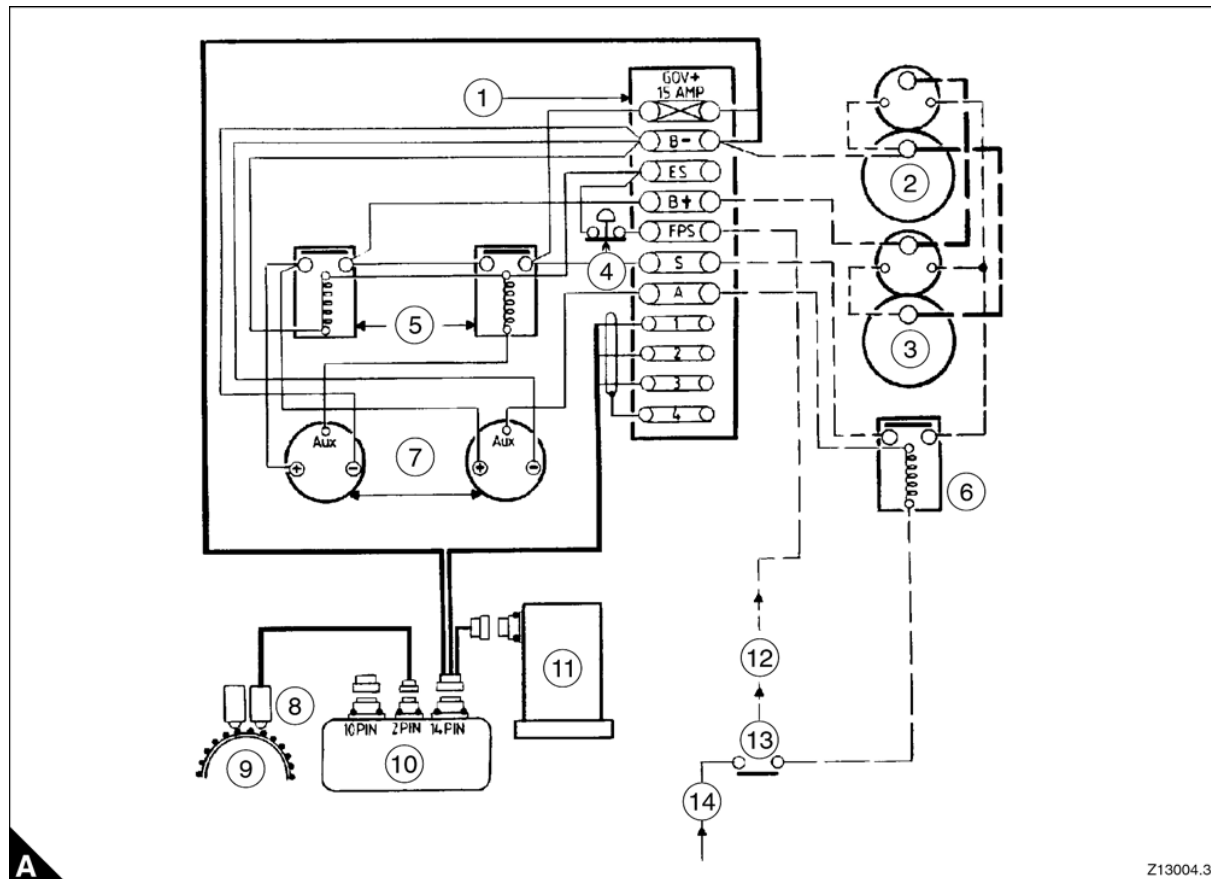

A

Z13004.3

4012 engine wiring diagram (twin starters and electronic governor)

Item	Description	Item	Description
A1	Engine fitted terminal box	A13	Overspeed
A2	Oil pressure switch	A14	'A' bank engine fault switches
A3	Starter motor 1	A15	'B' bank engine fault switches
A4	Starter motor 2	A16	Water temperature
A5	Battery charging alternator	A17	Water temperature
A6	Start inhibit relay	A18	Oil pressure
A7	Emergency stop switch	A19	Oil pressure
A8	Starter relay	A20	Magnetic pick-ups
A9	Two air shutoff solenoid valves energise to stop (1). Must be manually reset after operating	A21	Engine flywheel
		A22	Electronic governor control box
A10	Fuel stop solenoids energised to run	A23	Electronic governor actuator
A11	Two switch speed unit	A24	Typical linking box to controller
A12	Speed ref.		

(1) To operate only in conjunction with overspeed fault.

Notes:

- All switches are shown with the engine at rest.
- The diagram refers to standard engine wiring on engines fitted with a terminal box.

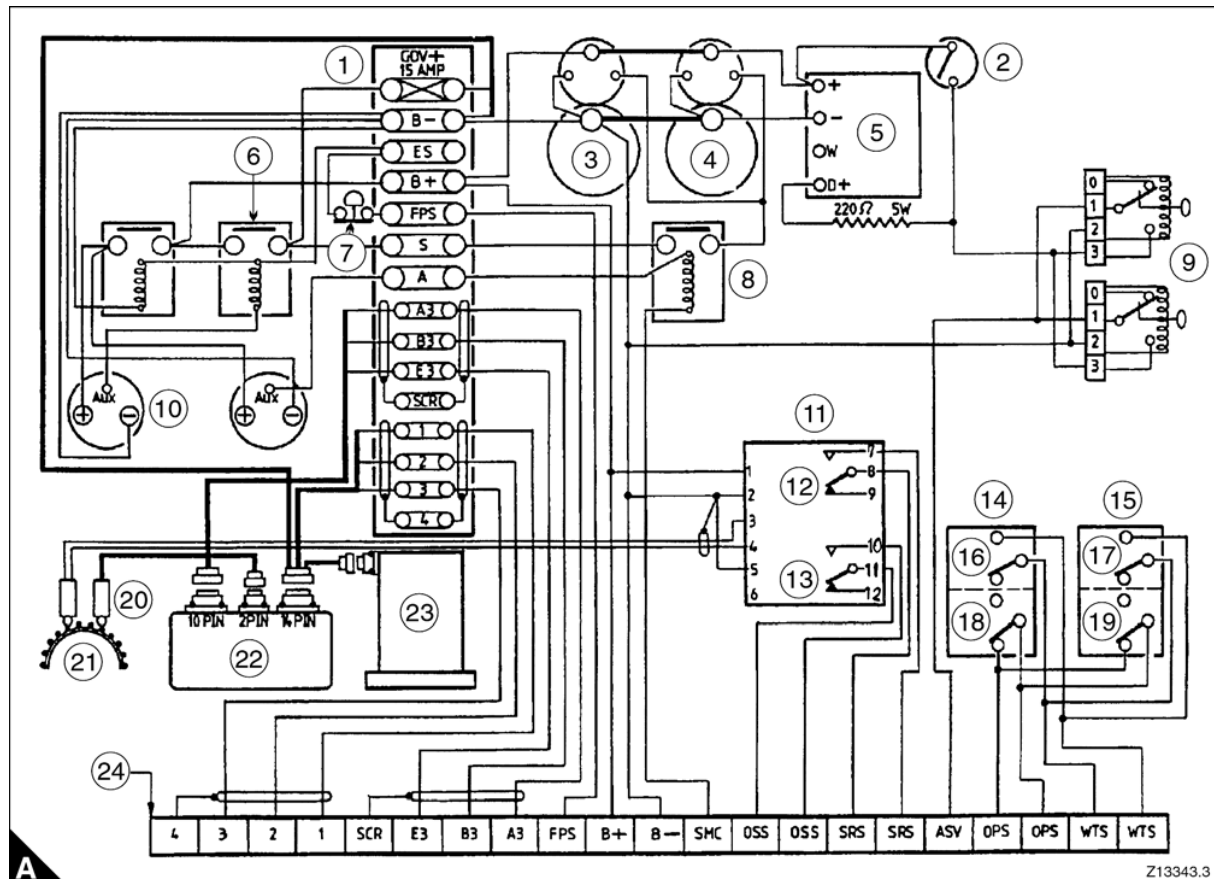

4016 engine wiring diagram (twin starters and electronic governor)

Item	Description	Item	Description
A1	Engine fitted terminal box	A13	Overspeed
A2	Oil pressure switch	A14	Magnetic pick-ups
A3	Starter motor 1	A15	Engine flywheel
A4	Starter motor 2	A16	Electronic governor control box
A5	Battery charging alternator	A17	Electronic governor actuator
A6	Start inhibit relays	A18	'A' bank engine fault switches
A7	Emergency stop switch	A19	'B' bank engine fault switches
A8	Starter relay	A20	Water temperature
A9	Four air shutoff solenoid valves energise to stop (1). Must be manually reset after operating	A21	Water temperature
		A22	Oil pressure
A10	Fuel stop solenoids energised to run	A23	Oil pressure
A11	Two switch speed unit	A24	Typical linking box to controller
A12	Speed ref.		

(1) To operate only in conjunction with overspeed fault.

Notes:

- All switches are shown with the engine at rest.
- The diagram refers to standard engine wiring on engines fitted with a terminal box.

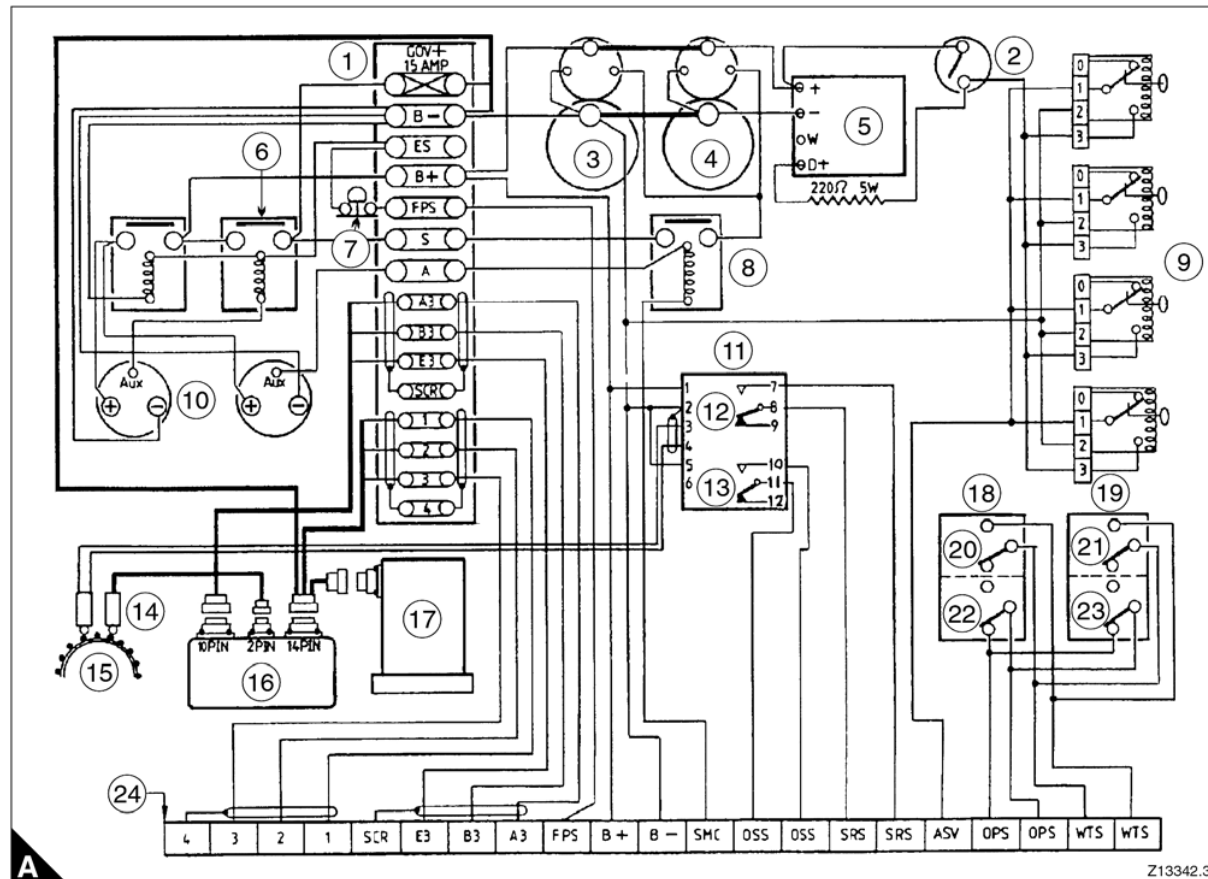

Z13342.3

2

Engine views

Introduction

Perkins engines are built for specific applications and the views which follow do not necessarily match your engine specification.

12 cylinder engines

'B' Bank (gearcase end)



'A' Bank (flywheel end)

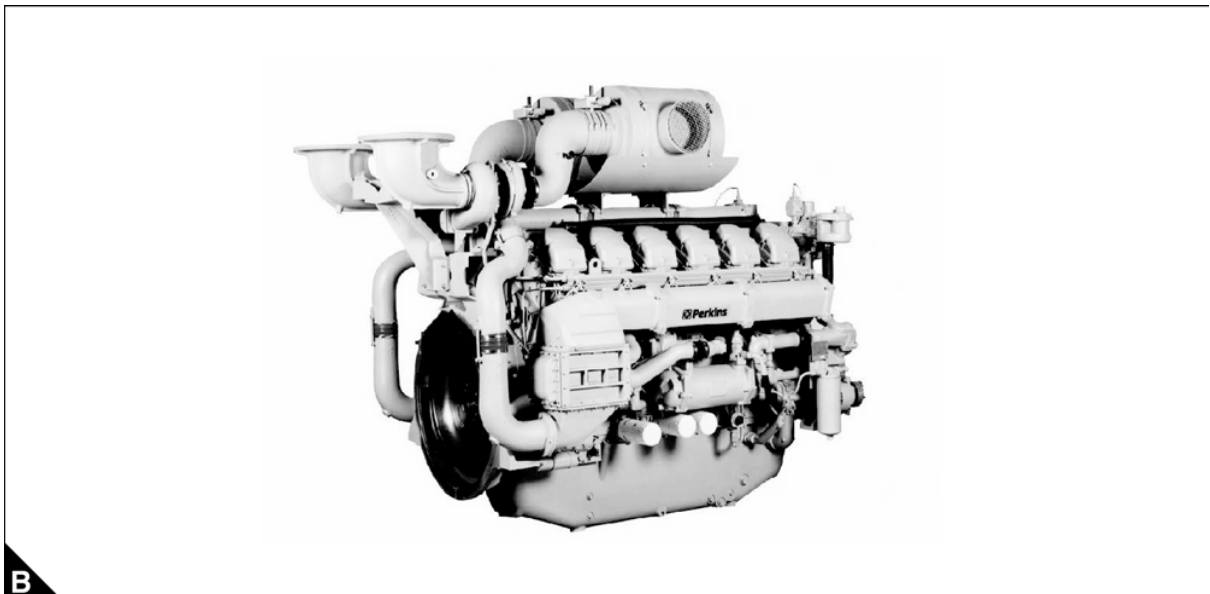

16 cylinder engines

'B' Bank (gearcase end)

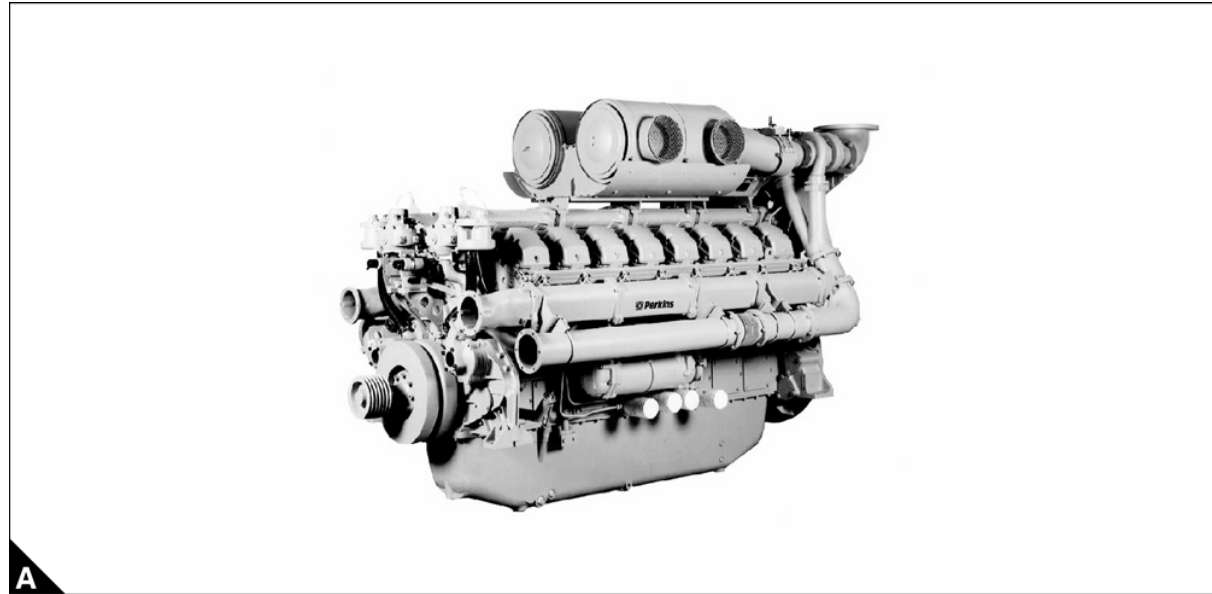

'A' Bank (flywheel end)

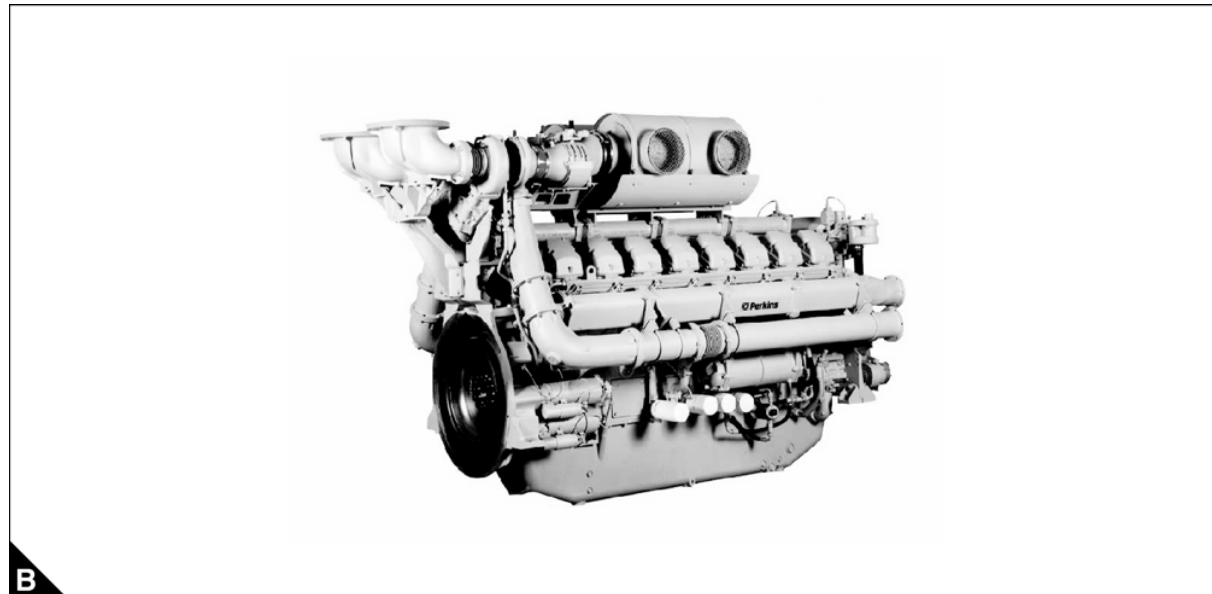

3

Operating instructions

Introduction

Information for the mechanical maintenance of the 4012/16 diesel engines is given in this User's Handbook (TSL 4186E) and the Workshop Manual (TSL 4165E).

These publications should be understood and used together for the safe operation of the engine.

Note: For oil and coolant details refer to [Chapter 5, Engine fluids](#).

Engine instrumentation

General description

The standard instrument panel is normally supplied as a loose item, but can be fitted to 'A' bank air inlet manifold.

The individual components of the instrument are shown in (A), and listed below:

Item	Description
A1	Coolant temperature gauge
A2	Lubricating oil temperature gauge
A3	Lubricating oil pressure gauge
A4	Battery charging rate gauge
A5	RPM and hours run indicator
A6	Fuse holder
A7	Three position keyswitch
A8	Exhaust temperature gauge (when fitted)

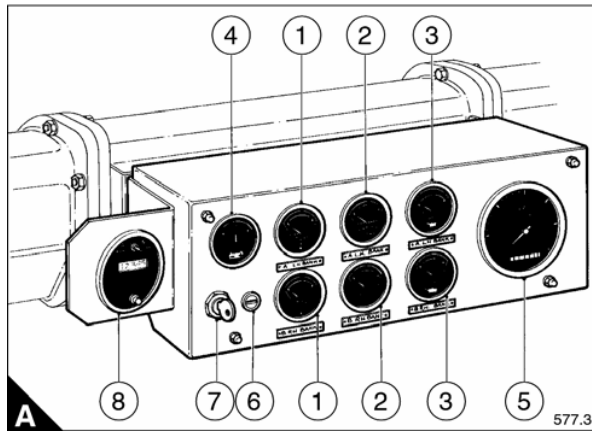

Instrument operation

Engine coolant temperature (A)

- 1 The temperature during normal operation should be between 65 °C - 85 °C (149 °F - 185 °F).
- 2 If the temperature should rise above 93 °C (200 °F) the engine protection switch will automatically stop the engine.
- 3 Investigate the cause.

Engine oil temperature (B)

The lubricating oil temperature should be between 80 °C - 90 °C (176 °F - 194 °F) when the engine is hot.

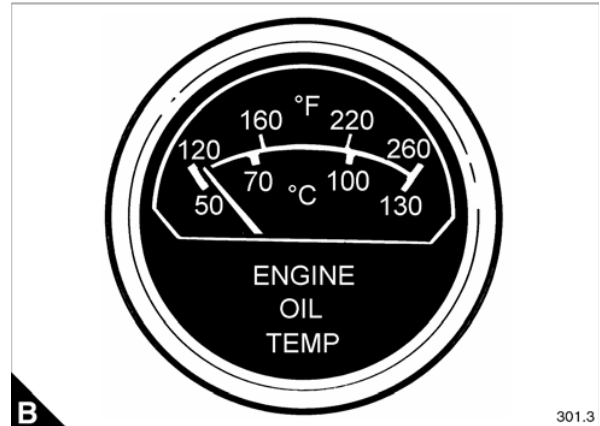
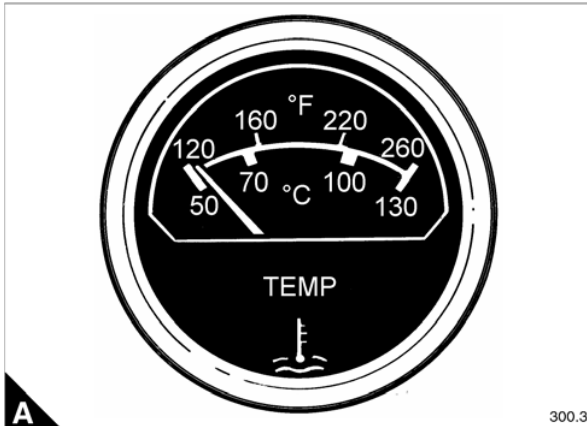

Engine oil pressure (C)

- 1 The lubricating oil pressure should be between 300 - 350 kPa (45 - 50 lb/in²) when the engine is hot.
- 2 If the pressure should drop below 200 kPa (30 lb/in²) at engine operating speed the engine protection switch will automatically stop the engine.
- 3 Investigate the cause.

Ammeter (D) (if fitted)

The ammeter indicates the charge rate to the batteries from the alternator.

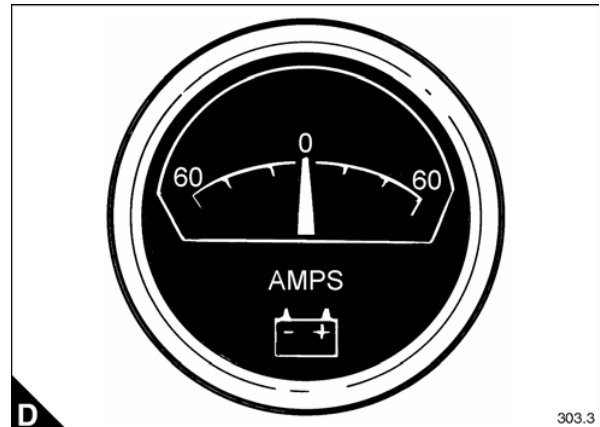
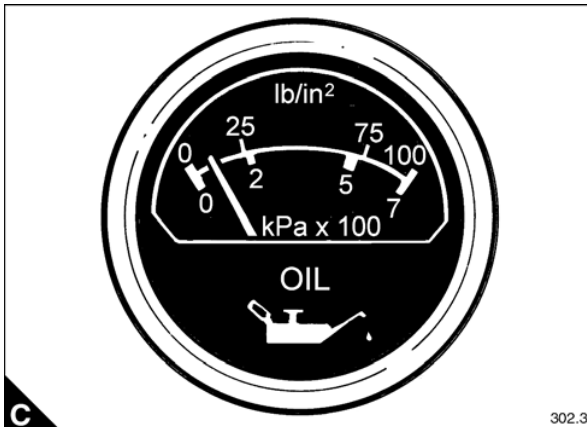

Tachometer and hour counter (E)

The electrically operated tachometer/hour counter shows the speed of the engine and the actual operating hours the engine has run.

Three position keyswitch (F)

The hand operated keyswitch with switch lock is moved by a separate key to the following positions:

- Engine Off (F1)
- Engine Running (F2)
- Engine Start (F3)

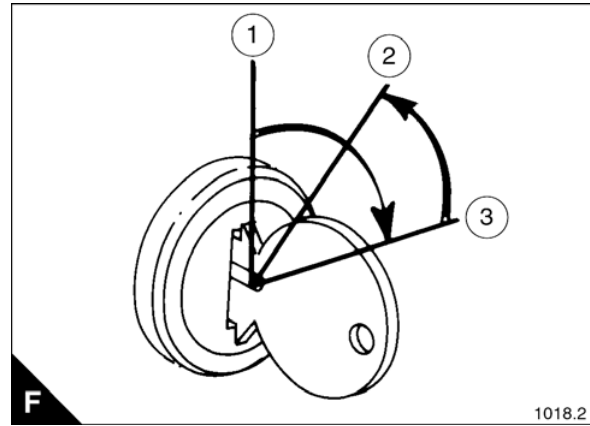
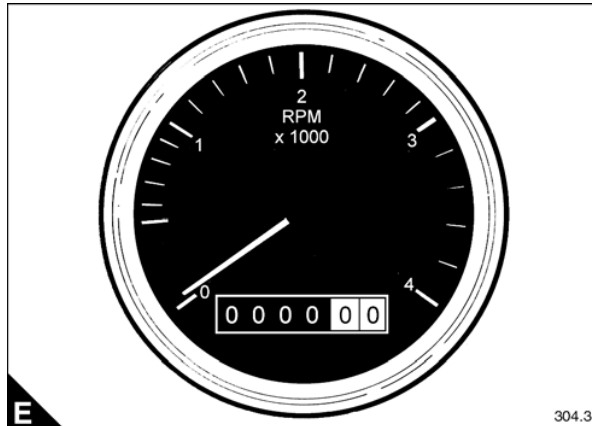
**Fuse holder (G)**

To protect the instrument panel a 2 amp fuse is fitted. To remove the fuse unscrew the holder (G1) and withdraw the fuse (G2).

Two point exhaust temperature gauge (H) (Optional)

The two point gauge measures the exhaust temperature of both banks after the turbochargers.

To switch the reading from one bank to the other operate the switch on the face of the gauge (H1).

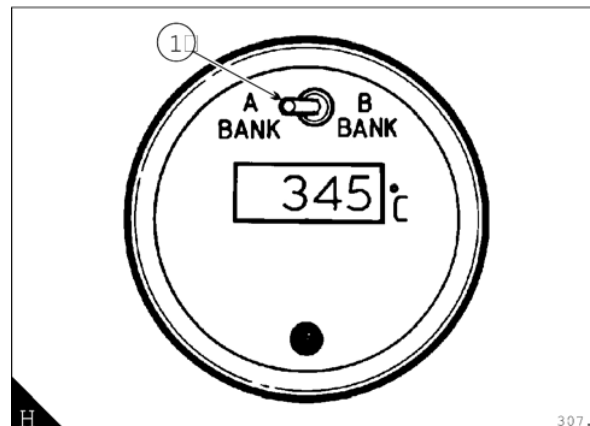
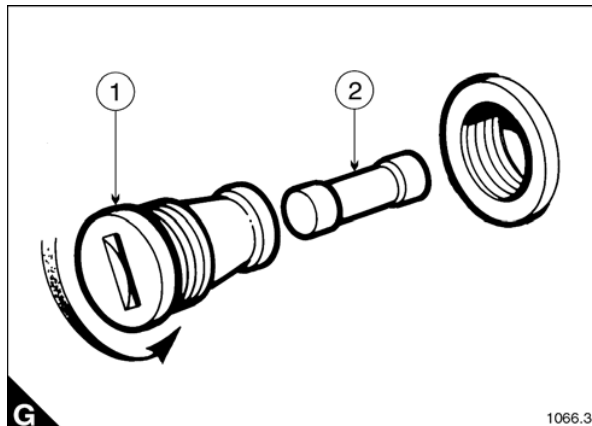

How to fill the engine with oil

- 1 Remove the sump drain plug and check that the sump is clean and empty. Refit and tighten the plug.
- 2 Remove the oil filler plug situated on the side of the crankcase by rotating the T-bar (A1) anti-clockwise and pulling.
- 3 Fill the sump to the maximum mark on the dipstick (A1) with an appropriate grade of oil as specified in ["Lubricating oil recommendations" on page 58](#).
- 4 Refit the oil filler plug.

Quantity of oil

Engine model	Sump capacity maximum	Dipstick minimum
4012	159 litre (35 gal)	136 litre (30gal)
4016	214 litre (47 gal)	147 litre (33 gal)

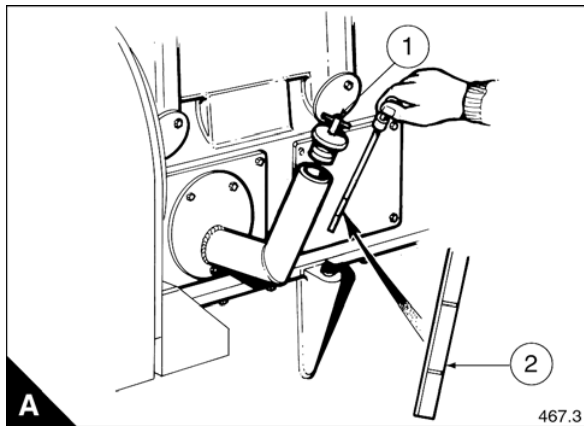

How to prime the lubrication system

Caution: Before starting the engine for the first time, or after it has stood idle for more than three months, the engine lubrication system **must** be primed.

To achieve this the engine is cranked over on the starter motors using the following procedure.

Note: To prevent the engine running during this operation disconnect the power lead to the actuator. Refer to (A1) for Heinzmann actuators and (A2) for Woodward actuators.

- 1 Manually set the air shutoff valves (B1) to the run position (B2).
- 2 Crank the engine over until 0,3 bar (5 lb/in²) shows on the oil pressure gauge.
- 3 Continue cranking for ten more seconds to ensure that oil is circulating through the turbochargers.
- 4 Reconnect the actuator power leads.

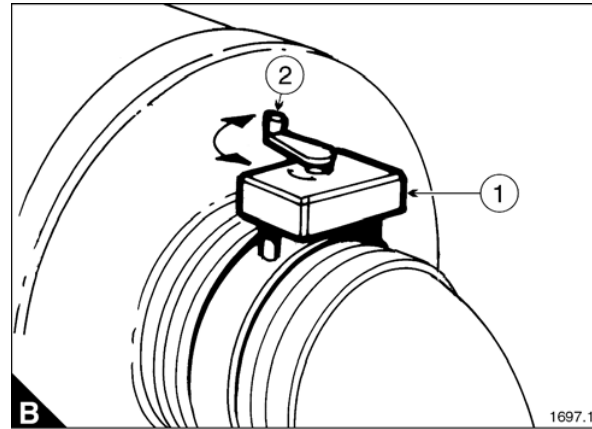
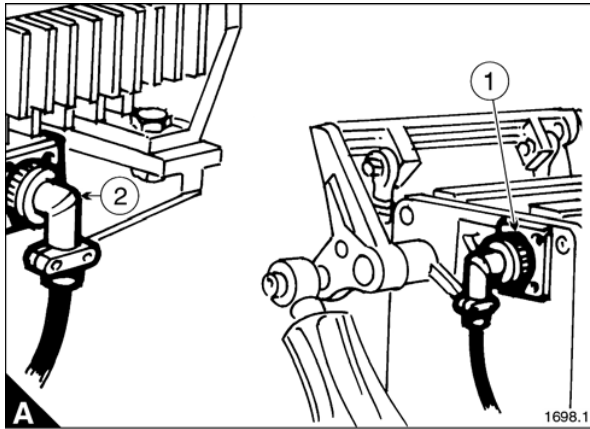

How to fill the engine and charge cooler cooling system (when fitted)

Combined engine and charge cooler radiator systems are normally supplied for individual installations. A separate radiator may be used by an OEM. The engine operator must be aware of the filler cap position.

Caution: All trapped air must be vented from the cooling systems. If an airlock is present on engine start up, localised overheating will occur, possibly causing engine damage.

Note: A solution of clean water and anti-freeze, or clean water and corrosion preventative, must be used in the engine and charge cooler systems, see "[Coolant specification](#)" on page 60.

Warning! Always stop the engine and allow the pressurised system to cool before removing the filler cap. Avoid skin contact with the coolant mixture.

To fill the engine system

- 1 Remove the vent plug (A1) from the pipe connecting the water rail to each thermostat.
- 2 Remove the radiator filler cap (B1). Fill the radiator until air free coolant flows from the vent.
- 3 Refit the vent plugs and continue filling until the coolant is 25 mm (1") below the filler neck (B2).

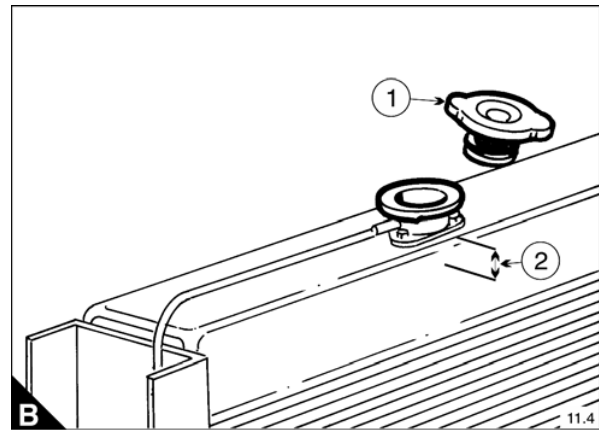
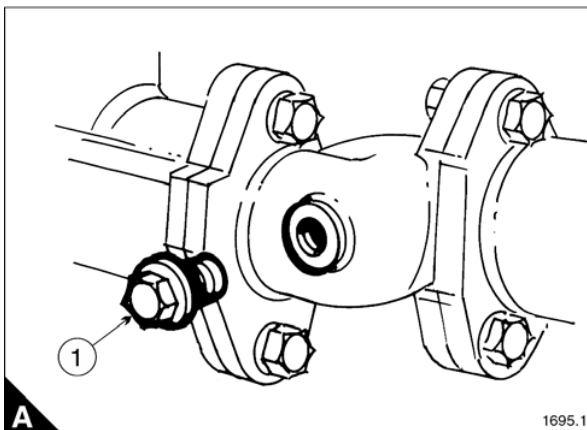

To fill the charge cooler system

- 1 Remove the charge cooler vent plugs (C1).
- 2 Remove the radiator filler cap (B1). Fill the radiator until air free coolant flows from the vent.
- 3 Refit the vent plugs and continue filling until the coolant is 25 mm (1") below the filler neck (B2).

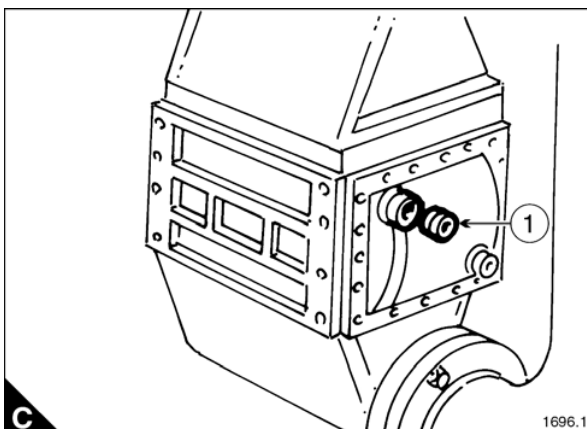

How to prime the fuel system (4012 engines with standard filter/water separator)

Caution: A small container or an absorbent material must be used to catch/soak up spilled fuel.

1 Loosen the fuel fitting nut (A1) on the fuel rail feed pipe, at the flywheel end of the fuel rail 'A' bank.

Note: Hold the fuel fitting (A2) in position when loosening the fuel fitting nut.

2 Operate the priming pump (B1) until air free fuel flows, then tighten the fuel fitting nut (A1).

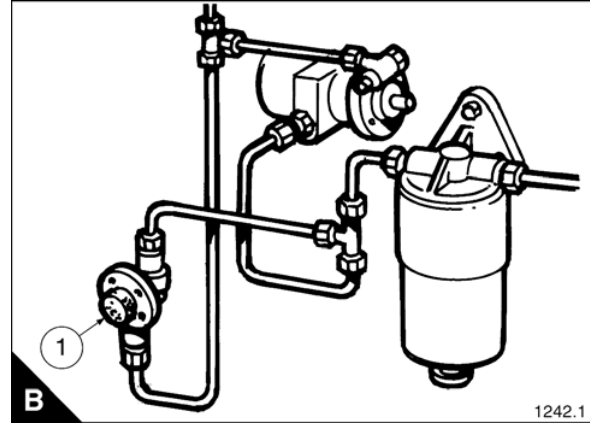
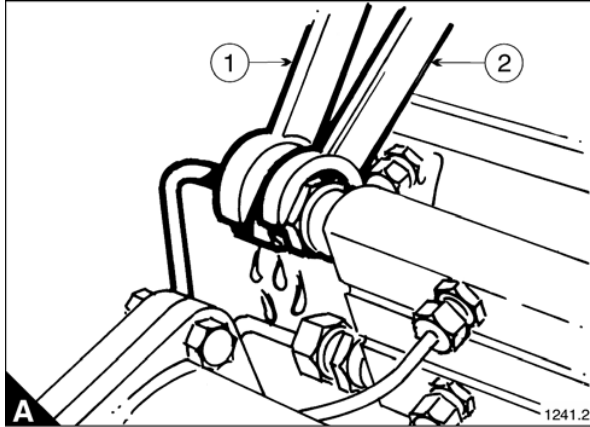

3 Repeat steps 1 and 2 for 'B' bank.

4 Loosen the fuel fitting nut (C1) on the fuel return pipe, cylinder No. 1 'A' bank, at the gearcase end of the fuel rail.

Note: Hold the fuel fitting (C2) in position when loosening the fuel fitting nut.

5 Operate the priming pump (B1) until air free fuel flows, then tighten the fuel fitting nut (C1).

6 Repeat steps 4 and 5 for 'B' bank.

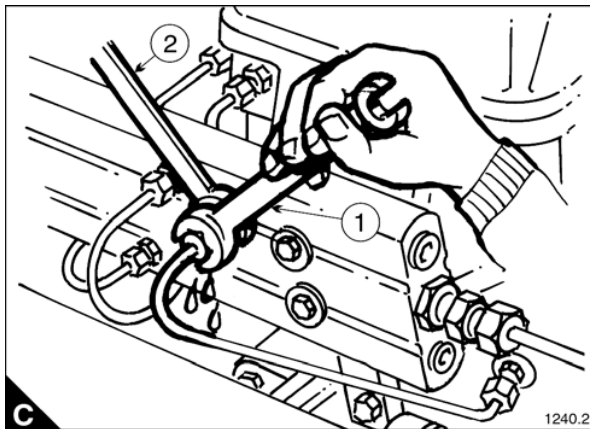

How to prime the fuel system (4016 engines with standard filter)

Caution: A small container or an absorbent material must be used to catch/soak up spilled fuel.

1 Loosen the fuel fitting nut (A1) on the fuel rail feed pipe, at the flywheel end of the fuel rail 'A' bank.

Note: Hold the fuel fitting (A2) in position when loosening the fuel fitting nut.

2 Operate the priming pump (B1) until air free fuel flows, then tighten the fuel fitting nut (A1).

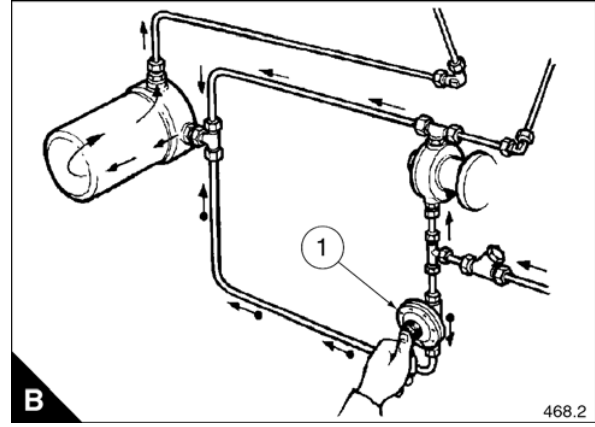
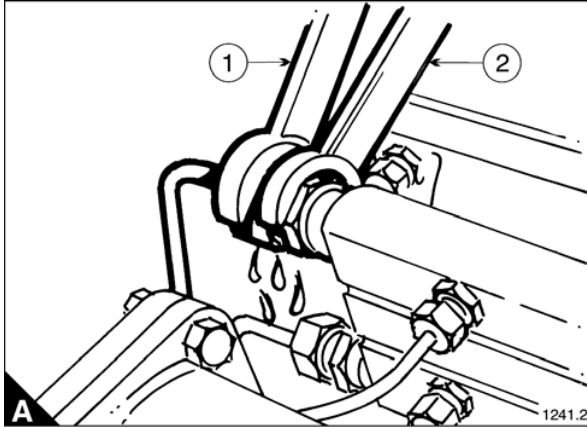

3 Repeat steps 1 and 2 for 'B' bank.

4 Loosen the fuel fitting nut (C1) on the fuel return pipe, cylinder No. 1 'A' bank, at the gearcase end of the fuel rail.

Note: Hold the fuel fitting (C2) in position when loosening the fuel fitting nut.

5 Operate the priming pump (B1) until air free fuel flows, then tighten the fuel fitting nut (C1).

6 Repeat steps 4 and 5 for 'B' bank.

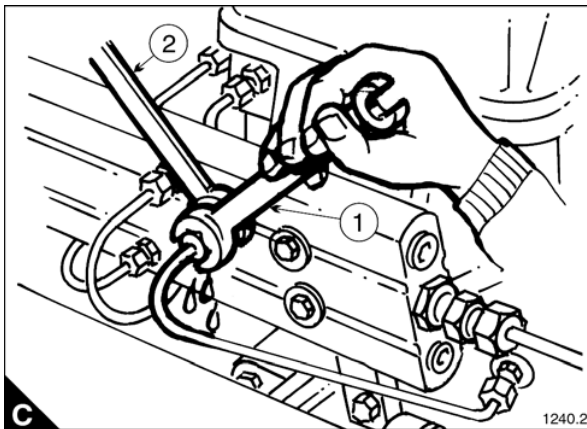

How to prime the fuel system (4012/16 engines with optional change-over filters)

Caution: A small container or an absorbent material must be used to catch/soak up spilled fuel.

- 1 Open the fuel vent screws (A1) on top of the change-over filters.
- 2 Operate the priming pump (B1) until air free fuel flows from the vent screws, then tighten the vent screws.

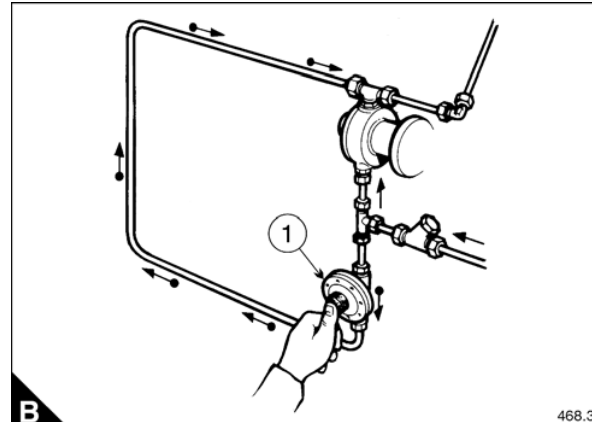
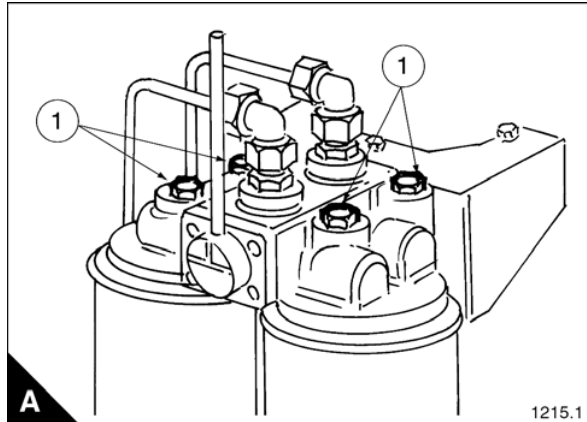

- 3 Loosen the fuel fitting nut (C1) on the fuel rail feed pipe, at the flywheel end of the fuel rail 'A' bank.
Note: Hold the fuel fitting (C2) in position when loosening the fuel fitting nut.
- 4 Operate the priming pump (B1) until air free fuel flows, then tighten the fuel fitting nut (C1).
- 5 Repeat steps 3 and 4 for 'B' bank.
- 6 Loosen the fuel fitting nut (D1) on the fuel return pipe, cylinder No. 1 'A' bank, at the gearcase end of the fuel rail.
Note: Hold the fuel fitting (D2) in position when loosening the fuel fitting nut.
- 7 Operate the priming pump (B1) until air free fuel flows, then tighten the fuel fitting nut (D1).
- 8 Repeat steps 6 and 7 for 'B' bank.

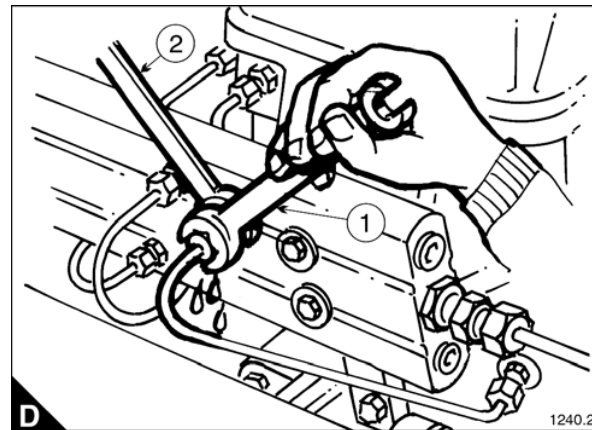
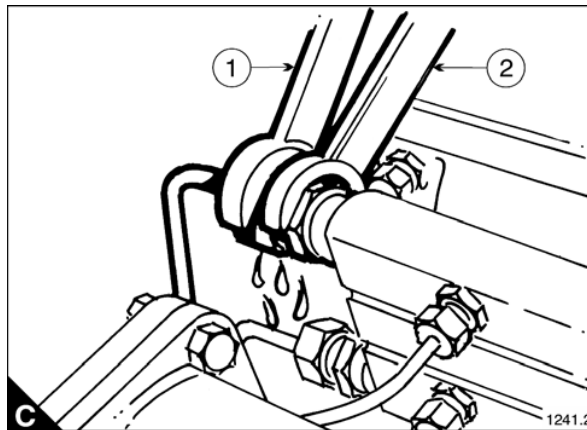

Final checks and first engine start

For the initial starting of a new or overhauled engine the following procedure should be followed.

- 1 Disengage the load. Check the air shut off valve is in the run position.
- 2 Turn the keyswitch to the start position. This will crank the engine over.
- 3 When the engine starts release the key, it will then move to the run position.

Note: For a short time the engine will not run on all cylinders. This is due to small air locks in the fuel system, which will automatically be vented as the engine continues to run.

- 4 Allow the engine to run for five minutes. Check the instrument panel readings. Check for fuel, coolant and oil leaks.
- 5 Stop the engine by turning the keyswitch to the stop position.
- 6 Check oil and coolant levels and top up as necessary.

Normal starting and shutdown procedure

Normal starting

- 1 Turn the keyswitch to the start position. The engine should start immediately.
- 2 Release the keyswitch.
- 3 Check the instrument panel readings.
- 4 Run the engine for a minimum of 15 seconds before applying load.
- 5 If the engine does not start within a few minutes then stop cranking and allow the engine to stop rotating.
- 6 Wait 10 seconds and try again.

Note: If after three attempts the engine does not start, investigate the cause.

Normal shutdown

- 1 Disengage the engine load.
- 2 Run the engine at no load for 5 minutes.

Note: This will allow the circulating lubricating oil to dissipate heat from the turbocharger.

4

Preventive maintenance

Maintenance procedures

These maintenance procedures are suitable for an engine working under average conditions.

If your engine is working under particularly dirty or dusty conditions, more frequent servicing will be necessary particularly in respect of the lubricating oil and air cleaners.

Correct and regular maintenance will help prolong engine life.

Warnings!

- *Make quite certain that the engine cannot be started before undertaking any maintenance.*
- *This is particularly important in the case of automatically starting generating sets or remote starting engines.*
- *Personal protective equipment must always be worn.*

Service schedule (prime and baseload rated engines)

Note: The following service schedules have been developed for engines using the standard oil filtration system.

The procedures indicated in the service schedule require reference to the following publications:

- User's Handbook - TSL 4186E (UH)
- Workshop Manual - TSL 4165E (WM)

A Service - First 100 hours

Description	Manual
Oil and filter - change	UH
Fuel filter - change	UH
Equalise bridge pieces and set valve clearance	UH
Fan and battery charging alternator taperlock drive pulleys - check	UH
Fan and battery charging alternator drive belts - check	UH

B Service - Every 250 hours

Description	Manual
Oil and filter - change (oil sampling recommended)	UH
Fuel filter - change	UH
Equalise bridge pieces, set valve clearance and check valve seat recession	UH
Breather systems - clean or replace element	UH
Air filter - replace (<i>subject to environmental conditions</i>)	UH
Governor actuator - lubricate ball joints	WM
Fan and battery charging alternator drive belts - check	UH

C Service - Every 2500 hours

Description	Manual
Oil and filter - change (oil sampling recommended)	UH
Fuel filter - change	UH
Equalise bridge pieces, set valve clearance and check valve seat recession	UH
Breather systems - clean or replace element, also replace valves on closed circuit system	UH
Air filter - replace (<i>subject to environmental conditions</i>)	UH
Fan and battery charging alternator drive belts - check	UH
Coolant mixture - check	UH
Magnetic pickup in flywheel housing - clean and set	WM

D Service - Every 7500 hours

Description	Manual
Cylinder heads - change	WM
Injector unit - test and replace if faulty	WM
Fuel system - flush out	WM
Charge cooler (engine mounted) - remove and clean	WM
Charge cooler (radiator type) - clean radiator matrices	WM
Coolant mixture - change	UH
Fan and battery charging alternator drive belts - replace	UH
Oil and filter - change (oil sampling recommended)	UH
Fuel filter - change	UH
Air filter - replace (<i>subject to environmental conditions</i>)	UH

E Service - Every 15,000 hours

Description	Manual
Cylinder heads - change	WM
Injector unit - test and replace if faulty	WM
Fuel system - flush out	WM
Fuel filter - change	WM
Charge cooler (engine mounted) - remove and clean	WM
Charge cooler (radiator type) - clean radiator matrices	WM
Coolant - change and check system	WM
Oil and filter - change (oil sampling recommended)	WM
Turbocharger - replace	WM
Oil cooler - clean and check	WM
Piston rings - change and deglaze liners	WM
Governor actuator - test	WM
Fan and battery charging alternator drive belts - replace	UH
Air filter - replace (<i>subject to environmental conditions</i>)	UH

F Service - Every 30,000 hours

Description	Manual
Cylinder heads - change	WM
Injector unit - test and replace if faulty	WM
Fuel system - flush out	UH
Fuel filter - change	WM
Charge cooler (engine mounted) - remove and clean	WM
Charge cooler (radiator type) - clean radiator matrices	WM
Coolant - change and check system	WM
Oil and filter - change (oil sampling recommended)	WM
Turbocharger - replace	WM
Oil cooler - clean and check	WM
Piston rings and liners - change	WM
Governor actuator - test	WM
Fan and battery charging alternator drive belts - change	UH
Coolant pump - change	WM
Oil pump - change	WM
Fuel lift pump - change	WM
Camshaft - change	WM
Cam followers - change	WM
Torsional vibration dampers - change	WM
Air filter - replace (<i>subject to environmental conditions</i>)	UH

Notes:

- Maintenance schedule from 30,000 hrs to 45,000 hrs is the same as 2,000 to 15,000 hrs.
- At 45,000 hrs operation consult Perkins Engines Company Limited, Stafford reference major overhaul and service exchange engine components.

Service schedule (stand-by duty engines)

The procedures indicated in the service schedule require reference to the following publications:

- User's Handbook - TSL 4186E (UH)
- Workshop Manual - TSL 4165E (WM)

This maintenance procedure is for engines used less than 400 hours in every 12 months.

A - Monthly

B - 3 Months

C - Every 500 hours or 6 months

D - Every 1000 hours or 12 months

A	B	C	D	Operation	Manual
●				Check the amount of coolant	UH
●				Check the lubricating oil level	UH
●				Check the restriction indicators for the air filters, and when necessary renew the filter elements	UH
	●			Start and run the engine on load until normal temperature of operation is reached	UH
●				Drain any water/sediment from the primary fuel filter	UH
			●	Check the condition and the tension of all drive belts	UH
			●	Check the specific gravity and the pH value of the coolant	UH
		●		Renew the lubricating oil and filter	UH
			●	Check radiator air restriction (visual)	UH
		●		Clean centrifugal oil filter	UH
		●		Renew the canister of the main fuel filter	UH
			●	Ensure that the fuel injectors are checked and corrected or renewed, if necessary	WM
			●	Equalise bridge pieces and check valve clearances	UH
			●	Clean and set magnetic pickup in flywheel housing	WM

Note: All bolts, hose clips, terminal connections, pipes and joints must be checked for tightness and leaks every 3 months.

Light load and stand-by generating sets

Engines operating on a load of less than 25-30% of rated output should be run on no load for 10 minutes weekly and once a year using a variable 'dummy load', building up gradually from zero to maximum over a four hour run, to burn off accumulations of carbon in the engine and exhaust system.

Warning! Failure to follow the instructions above can result in engine damage, and will invalidate the engines warranty.

How to check the lubricating oil level

- 1 Stop the engine and wait 5 minutes to allow the oil to drain into the sump.
- 2 Withdraw the dipstick and wipe clean.
- 3 Insert the dipstick and wait 2 seconds.
- 4 Withdraw the dipstick and check the level against the high and low marks.
- 5 If necessary, put more oil into the sump. Use the same grade and specification as that already in the system.

Caution: Do NOT overfill.

How to check the coolant level

Warning! Always stop the engine and allow the pressurised system to cool before removing the filler cap. Avoid skin contact with the coolant mixture.

- 1 Remove the filler cap.
- 2 The coolant level should be 25 mm (1") below the top of the filler neck.

Caution: If coolant is added to the system during the service, it must consist of the same original mixture as used to fill the system.

- 3 Refit the filler cap.

How to check and clean the radiator (if fitted)

Special requirements

Special tools			
Description	Part number	Description	Part number
Air compressor	UA	Steam cleaner	UA

Under normal operating conditions the radiator cooling fins should be inspected for a build up of dust and oil contamination every 3 months.

Caution: *If adverse site conditions exist inspections must be increased.*

Cleaning the radiator cooling fins

Note: To clean the cooling fins on the fan side of the radiator, the fan, its supports and the cowling must first be removed.

1 Dry dust and general contamination can be blown from the cooling fins using compressed air at a maximum pressure of 100 - 300 kPa.

2 To clean oil / dirt contamination, brush an industrial liquid detergent onto the fins.

Warning! *The detergent manufacturers instructions must be followed.*

3 Use a steam jet at a maximum pressure of 500 - 700 kPa to remove the contamination.

How to check and adjust the radiator fan drive belts (if fitted)

- 1 Remove the mesh guard from around the fan belts.
- 2 Grease the fan bearings and jockey pulley bearings.
- 3 Check the tension and wear of the fan belts using hand pressure midway between the crankshaft and the pulley. A total deflection of 12,5 mm (0.5") is satisfactory (A1).

Note: If the fan belts are worn the complete set should be replaced and the fan pulley to crankshaft pulley alignment checked.

4 If adjustment is necessary slacken the adjusting screws (A2). Using a tube extension (A3) on the jockey pulley move outwards to tension the belts and inwards to slacken.

5 With the tension set, tighten the adjusting screws (A2).

6 Refit the mesh guard.

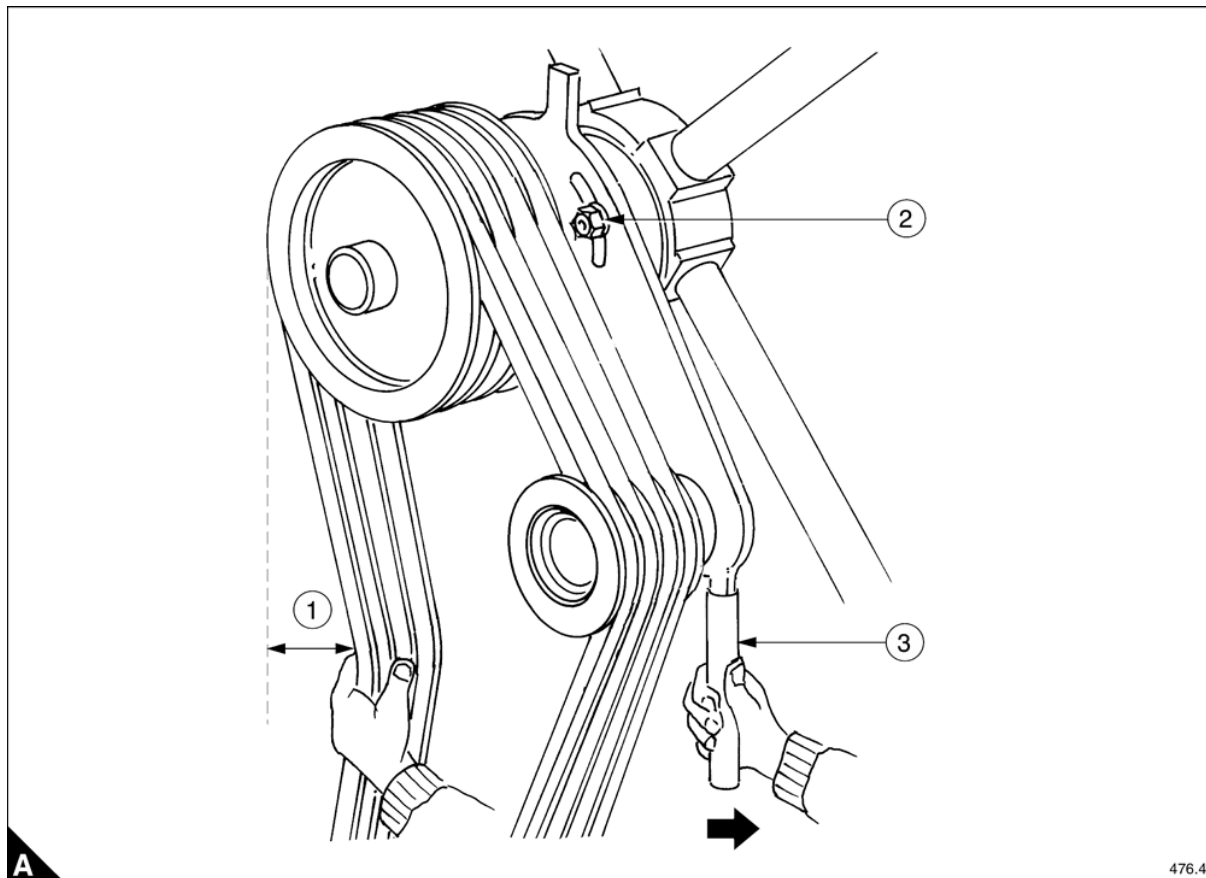

A

476.4

How to check and adjust the battery charging alternator (if fitted)

Caution: The toothed belt used to drive the alternator relies on tooth engagement to transmit the load. It does not require pre-loading.

- 1 To inspect the drive belt remove the guard (A1).
- 2 Visually inspect the drive belt, checking that the drive teeth and the smooth outer face are undamaged.
- 3 Check belt tension using light finger pressure midway between the pulleys (A2). A deflection of 1,5 mm ($\frac{1}{16}$ ") is correct.
- 4 To adjust the belt tension slacken the pivot bolt (A3) and the tensioning arm bolts (A4). Set the belt tension, then retighten all the bolts.
- 5 Refit the guard (A1).

Note: To replace the drive belt refer to Chapter 14 in the Workshop Manual.

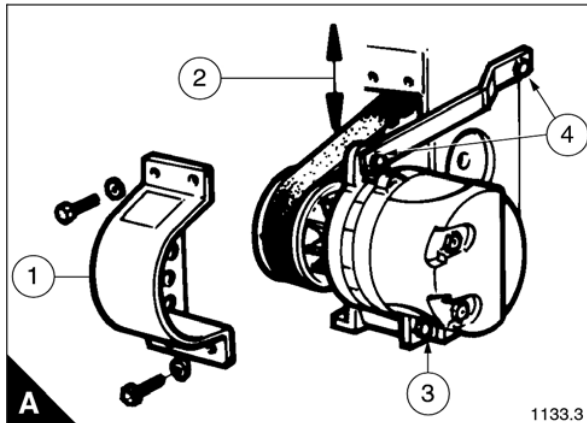

How to change the engine oil and standard oil filter

Draining the engine sump

A container with the following capacity will be required:

- 12 cylinder engines - 159 litres (35 gal)
- 16 cylinder engines - 214 litres (47 gal)

- 1 Remove the sump drain plug and allow the oil to drain into the container.
- 2 Place a container with a capacity of 5 litres (1 gal) under the filters to catch the oil which will be released as they are removed.
- 3 Remove the oil filters using a strap wrench, turning the filter anti-clockwise (A).

Caution: *The piston cooling jet filters must be changed at the same time as the main engine oil filters.*

- 4 Clean the sealing faces and the threaded bosses of the oil filter header.
- 5 Lightly lubricate the sealing ring of the new filters with engine oil.
- 6 Screw each filter up to the header using firm hand pressure.
- 7 Refit the sump drain plug and refill the engine with the correct grade of lubricating oil as given in "[Lubricating oil recommendations](#)" on page 58.

Caution: *Prime the lubrication system before starting the engine, refer to "[How to prime the lubrication system](#)" on page 26.*

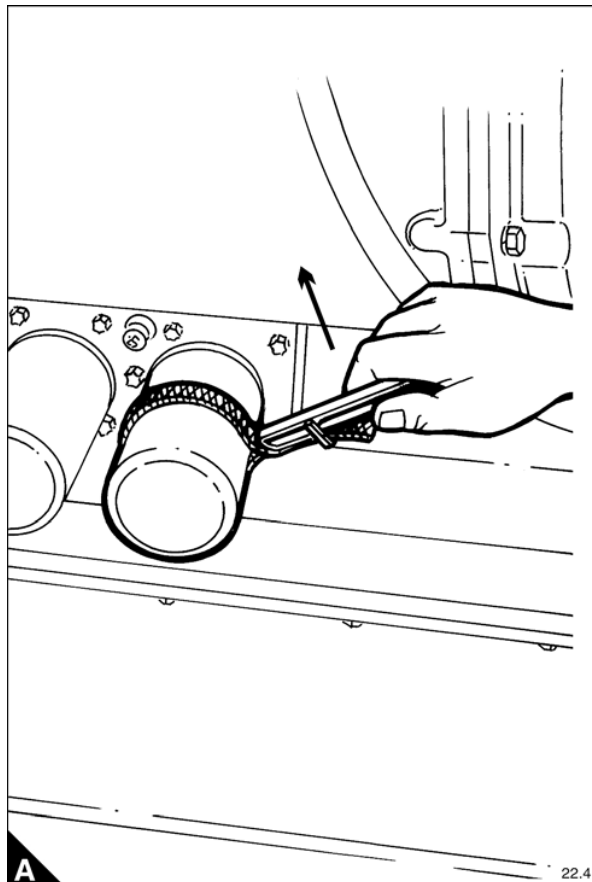

How to change the change-over filters (if fitted)

With engine running

- 1 With both filters on line the marking on the change-over valve will be as (A1).
- 2 Using a spanner turn the change-over valve to position (A2) directing the oil away from the right hand filter.
- 3 Remove the filter using a strap wrench, turning the filter anti-clockwise.

Caution: Prepare for a small oil spillage as the filter is removed.

- 4 Clean the sealing face and threaded boss of the filter header.
- 5 Fill the new filter with oil and lightly lubricate the sealing ring.
- 6 Screw the filter up to the header using firm hand pressure.
- 7 Turn the change-over valve back to position (A1).
- 8 Turn the change-over valve to position (A3) and change the left hand filter.

Note: View (A4) shows oil flow from engine to filters. View (A5) shows oil flow from filters to engine.

With engine stopped

Follow the procedure for standard filters given in ["How to change the engine oil and standard oil filter" on page 42.](#)

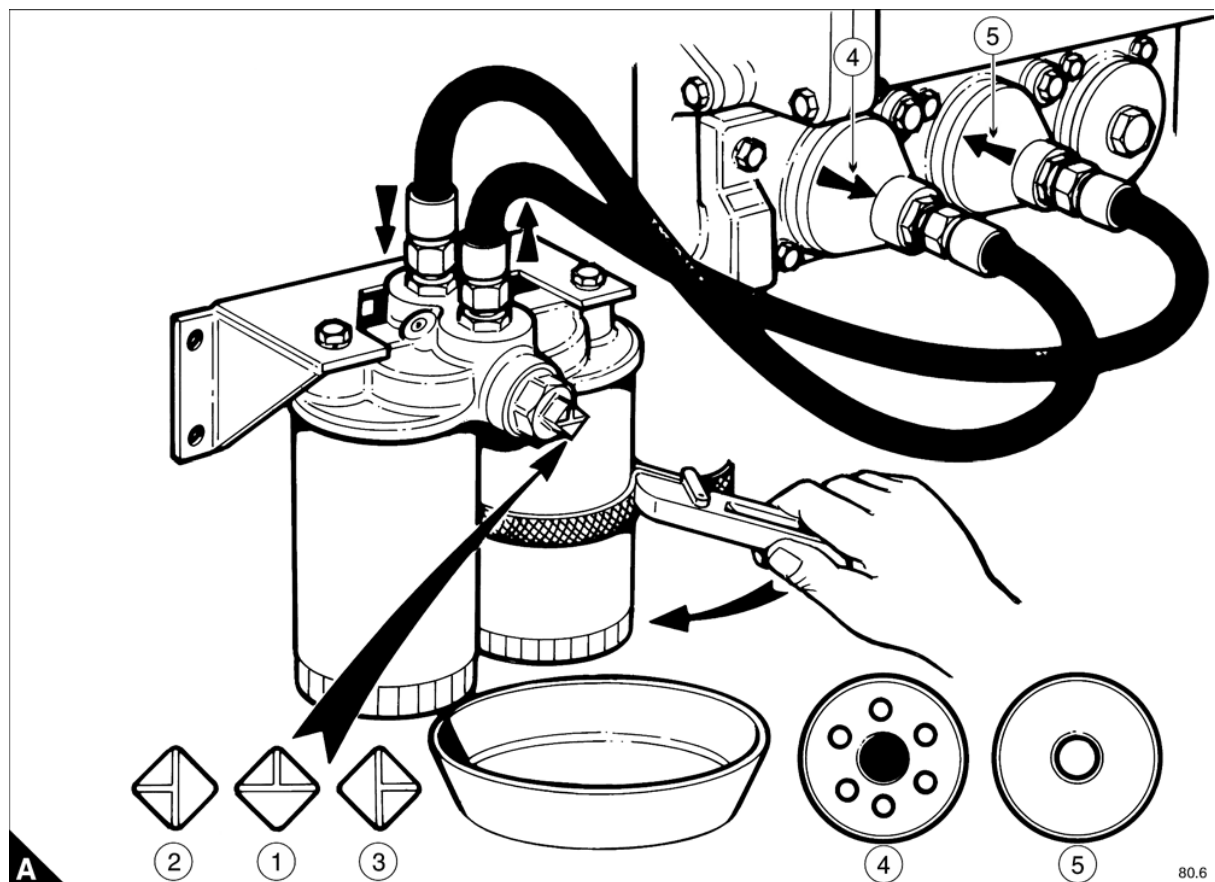

How to clean the centrifugal oil filter (if fitted)

Special requirements

Special tools	
Description	Part number
Rotor stand tube removal tool	T6253/293

- 1 Stop the engine and wait for the rotor to stop spinning.
 - 2 Slacken the clamping band (A1). Unscrew the 'T' bar (A2) and lift off the cover (A3).
 - 3 Remove the knurled nut (A4) and lift the rotor assembly (A5) off the spindle (A6).
 - 4 Turn the rotor assembly over and fit the removal tool (B1). Tighten the nut (B2) to pull the stand tube (B3) and 'O' ring (B4) from the rotor body (B5).
 - 5 Remove the sludge deposits and the paper insert (B6) from the rotor body using a spatula. Clean all deposits from the stand tube and rotor body using a suitable cleaning fluid.
 - 6 Fit a new paper insert into the rotor body. Check the condition of the 'O' ring (B4) and refit, or if necessary, replace with a new one.
 - 7 Fit the stand tube into the rotor body, carefully aligning the rotor body locating pin in the stand tube.
 - 8 Lubricate the spindle (A6). Fit the rotor assembly (A5) and tighten the knurled nut (A4).
- Note:** Check the rotor spins freely.
- 9 Fit a new, or if serviceable, the original 'O' ring (A7) to the filter body. Fit the filter cover (A3) and tighten down the retaining 'T' bar (A2). Fit the clamping band (A1).
 - 10 Prime the engine lubrication system, see ["How to prime the lubrication system" on page 26](#).
 - 11 With the engine running check for oil leaks.

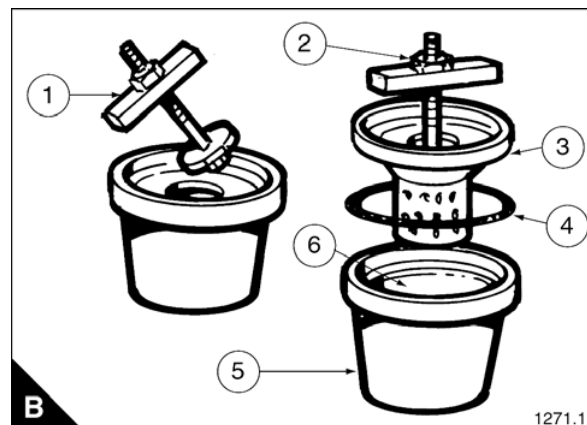
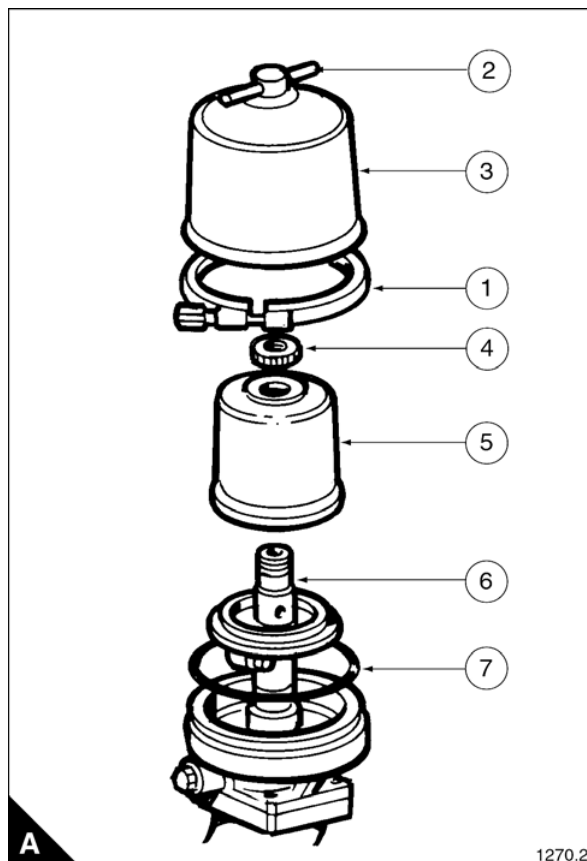

How to clean the crankcase breather system

Warning! Disconnect batteries or any other means of starting. Personal protective equipment must be worn.

Two crankcase breathers are fitted. They are mounted on the side of the thermostat housings.

- 1 Unscrew the wing nut (A1).
- 2 Remove top cover (A2).
- 3 Lift out the two wire mesh elements (A4) from the filter body.
- 4 Clean any oil sludge deposits from the breather body, cover and pipework.

Note: If there is an excessive amount of oil sludge, remove the unit for cleaning.

- 5 Wash the mesh elements in a suitable cleaning agent and shake dry. If compressed air is available blow dry.

Caution: If the mesh elements still retain a heavy deposit of oil sludge after cleaning, new elements must be fitted to ensure breather efficiency.

- 6 Refit the mesh elements into the filter body.
- 7 Check the sealing joint is in good condition and replace if required. Fit the cover making sure it has located on its dowel (A3).
- 8 Tighten the wing nut (A1).

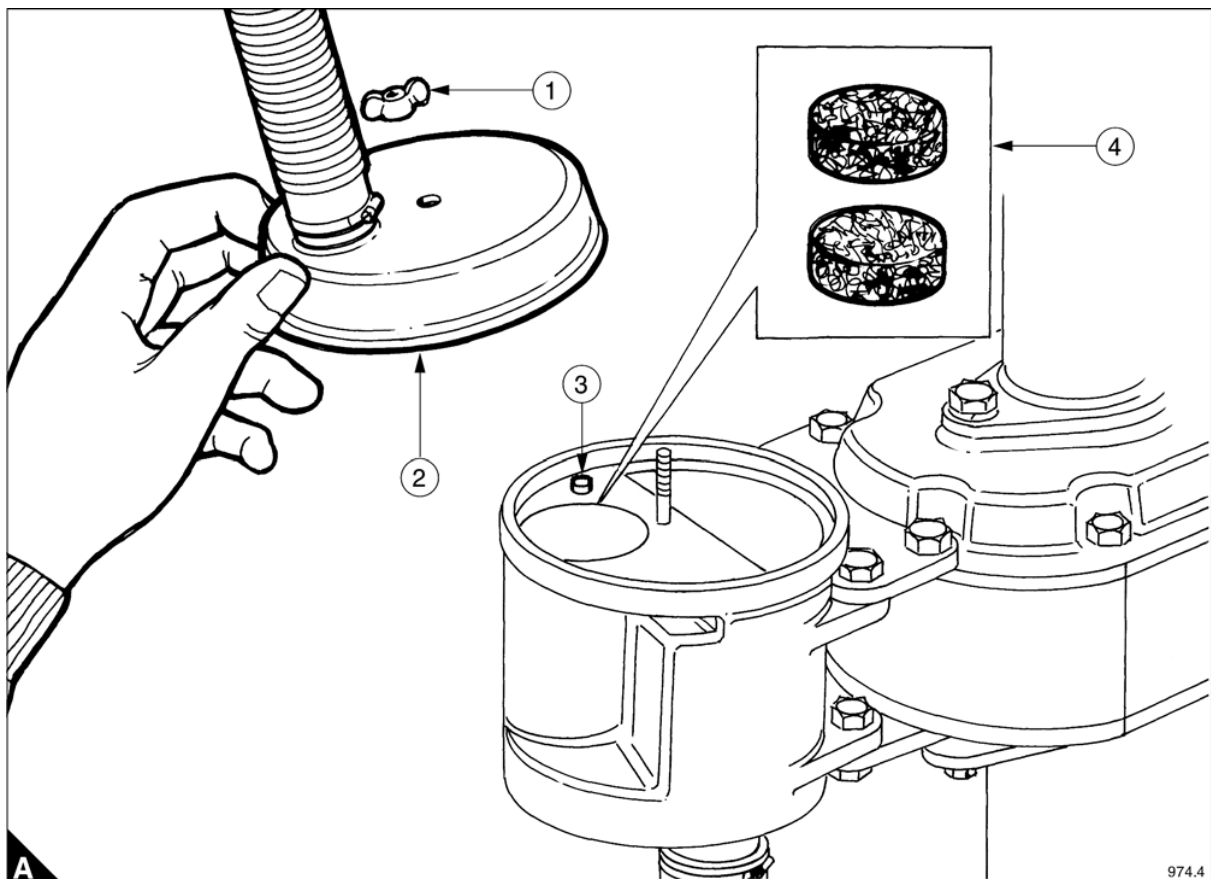

How to change the standard fuel filter / water separator (4012 engines)

Special requirements

Special tools	
Description	Part number
Strap wrench	UA

Draining the filter / separator

Warnings!

- Disconnect batteries or any other means of starting the engine. Always wear protective gloves.
- This operation must be done with the engine stopped.

Note: Water collected in the separator should be drained off weekly.

- 1 Leave the fuel supply turned on.
- 2 Place a container (A1) under the filter / separator unit (A2).
- 3 Open the self venting valve (A3) until water free fuel flows, then close the valve.

Changing the filter / separator

- 1 Turn off the fuel supply.
- 2 Remove the filter separator canister using a strap wrench (A4).
- 3 Fill the new filter / separator canister with clean fuel. Apply clean engine oil to the rubber sealing ring then carefully screw the new canister up to the housing. Use firm hand pressure only.
- 4 Turn on the fuel.

Note: The small amount of air trapped in the system after changing a filter will automatically be vented by the engine.

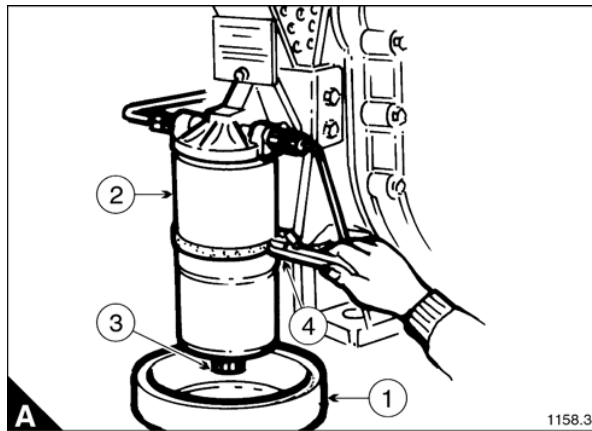

How to change the standard fuel filters (4016 engines)

Special requirements

Special tools	
Description	Part number
Strap wrench	UA

Warnings!

- Disconnect batteries or any other means of starting the engine. Always wear protective gloves.
- This operation must be done with the engine stopped.

Cleaning the fuel strainer

- 1 Turn off the fuel supply.
- 2 Remove the strainer (A1) from its housing (A2) in the fuel feed pipework.
- 3 Shake any loose particles from the gauze filter (A3) then refit the strainer.

Changing the fuel filter

Note: Removal of the filters will allow a small escape of fuel from the filter housing and pipes. Place a container under the housing before filter removal.

- 1 Remove a fuel filter by turning it anti-clockwise using a strap wrench (B1).
- 2 Wipe clean the sealing faces and threaded bosses of the filter housings.
- 3 Apply clean engine oil to the rubber sealing ring of the new filter. Carefully screw the new canister up to the housing. Use firm hand pressure only.
- 4 Turn on the fuel.

Note: For a short time the engine will not run on all cylinders. This is due to small air locks in the fuel system, which will automatically be vented as the engine continues to run.

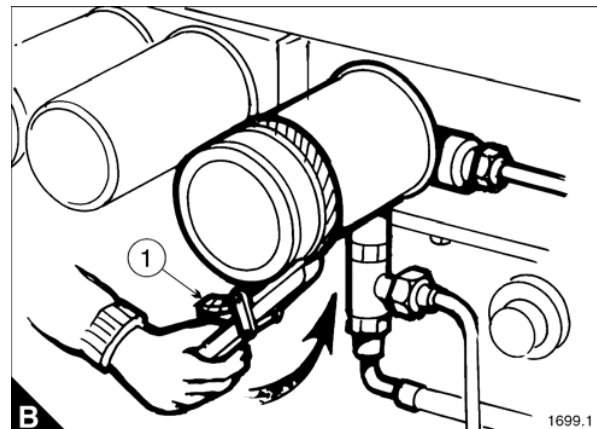
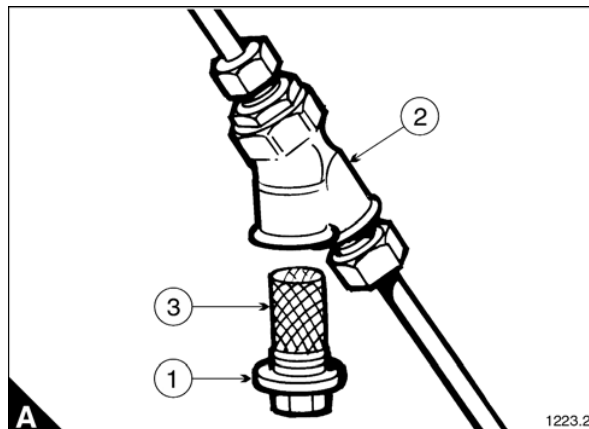

How to change the optional change-over fuel filters with the engine running

Special requirements

Special tools	
Description	Part number
Strap wrench	UA

The operation of the change-over filter is controlled by a three position lever (A). The three positions are:

- Normal position is with the change-over lever in the vertical position (A1).
- Moving the lever to the left (A2) puts the right hand filter out of service.
- Moving the lever to the right (A3) puts the left hand filter out of service.

1 With the lever positioned remove the appropriate filter canister using a strap wrench.

2 Fill the new filter canister with fuel.

3 Apply clean engine oil to the rubber sealing ring.

4 Carefully screw the new canister up to the housing using firm hand pressure only.

Note: Air must be vented from each new filter using the following procedure.

5 Slacken the vent screw (B2).

6 Slowly raise the lever (B1) towards the vertical position. Stop when air free fuel flows.

7 Tighten the vent screw. Return the lever to the vertical position.

8 Repeat the operation on the second filter.

9 Wipe any spilt fuel from the filter unit.

Note: The small amount of air trapped in the system after changing a filter will automatically be vented by the engine.

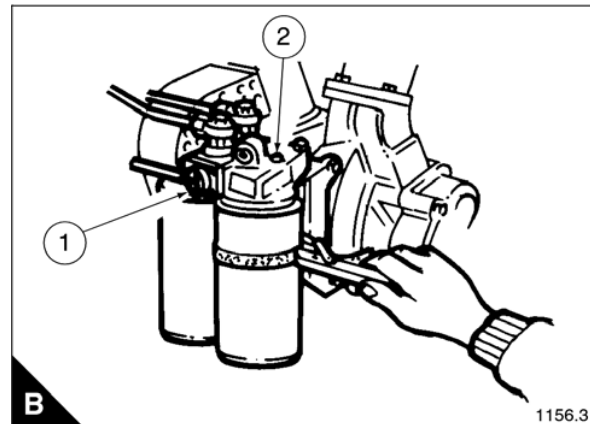
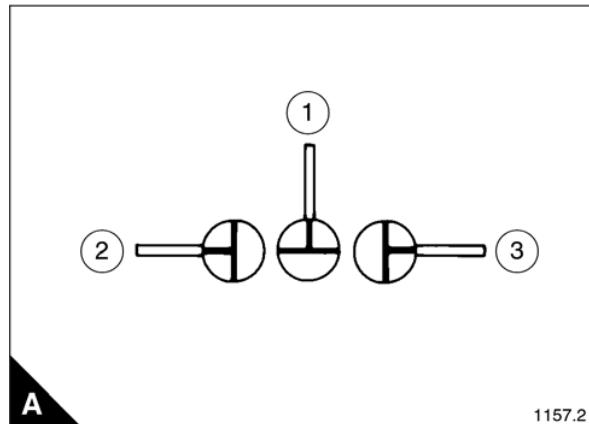

How to check the air cleaner restriction indicator

- 1 The middle section of the restriction indicator will remain clear while the air cleaner is in a serviceable condition.
- 2 When the filter reaches its contamination limit the restriction indicator will sense the change in manifold pressure and middle section (A1) will change to red. At this point the air filter must be changed.
- 3 When the air filters have been changed reset the indicator by pressing button (A2).

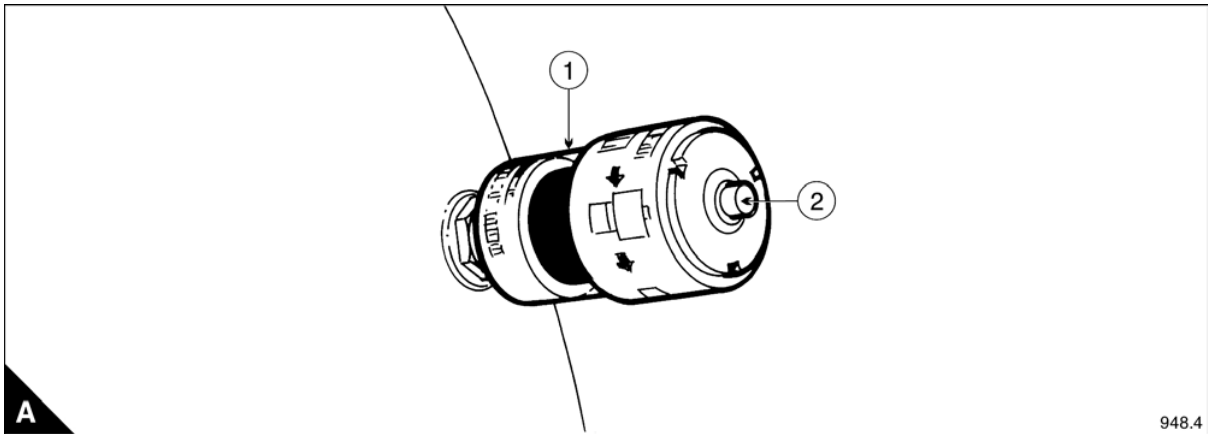

How to change the air filter element

- 1 Unscrew the wing nut (A1) and pull the end cover (A2) from the filter body.
- 2 Lift out the paper element (A3).
- 3 Clean any dust accumulation from inside the air filter body using a clean cloth.

Caution: Do not use compressed air as dust particles will be blown into the turbo and inlet manifolds.

- 4 Fit the new air filter into the filter body.
- 5 When fitting the end cover check it is fully seated before tightening the wing nut.

Cleaning the cyclone unit

For heavy duty air filtration a cyclone unit (A4) is fitted to the filter intake replacing the mesh guard.

- 1 To clean the cyclone unit remove it from the air filter intake.
- 2 Using compressed air remove any accumulated dust from the body of the unit.
- 3 Refit to the air filter intake.

Warning! When using compressed air personal protective equipment must be worn.

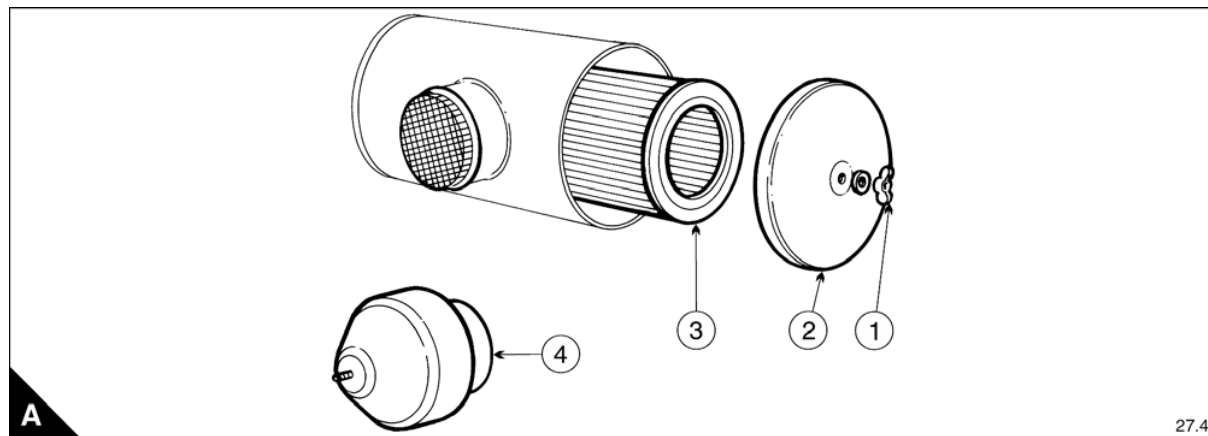

Preparation for equalising bridge pieces and setting valve clearances

Special requirements

Special tools	
Description	Part number
Engine cranking device	SE253

- 1 Take out the screws (A1) and remove all of the engine rocker covers (A2).
- 2 Fit the engine cranking device (B1) to a starter mounting in the flywheel housing (B2).
- 3 Using a socket and ratchet wrench press against the spring loaded bolt head (B3) until the pinion engages with the flywheel gear.

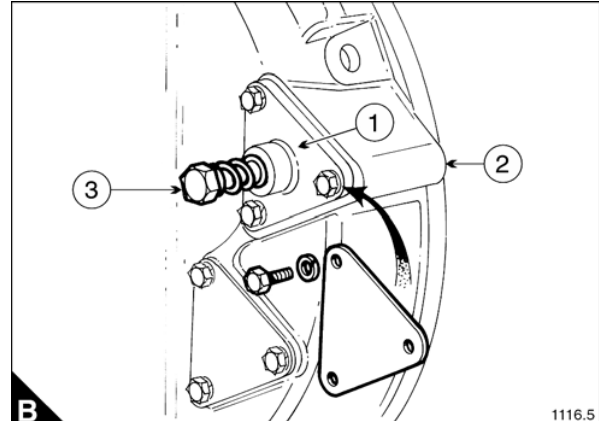
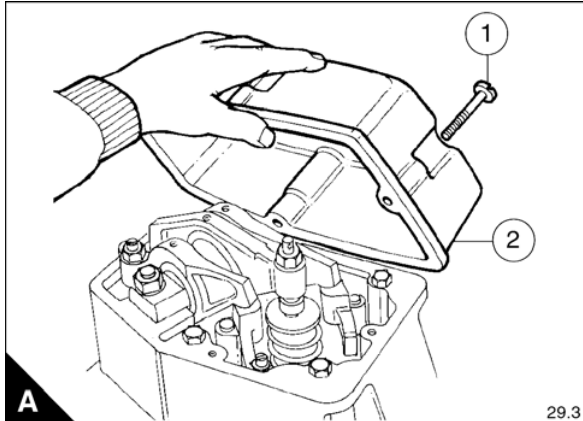

- 4 Crank the engine to the desired position, using flywheel markings viewed through the inspection hole in the flywheel housing (C1). Refer to ["Bridge piece and valve clearance setting sequence" on page 52](#).

Note: To get an accurate reading line up by eye the tip of both pointers with the marks on the flywheel (C2).

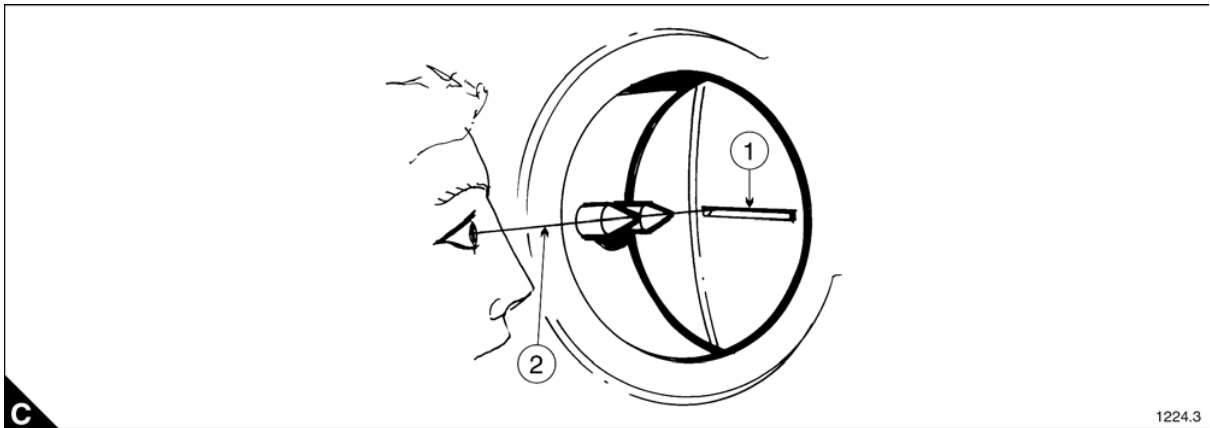

Bridge piece and valve clearance setting sequence

12 cylinder engines (A)

T.D.C. (Top Dead Centre)	Valves rocking on cylinder No.	Set bridge piece and valve clearance on cylinder No.
A1 & A6	A6	A1
B1 & B6	B1	B6
A2 & A5	A2	A5
B2 & B5	B5	B2
A3 & A4	A4	A3
B3 & B4	B3	B4
A1 & A6	A1	A6
B1 & B6	B6	B1
A2 & A5	A5	A2
A2 & B5	B2	B5
A3 & A4	A3	A4
B3 & B4	B4	B3

16 cylinder engines (B)

T.D.C. (Top Dead Centre)	Valves rocking on cylinder No.	Set bridge piece and valve clearance on cylinder No.
A1 & A8	A8	A1
B1 & B8	B8	B1
A3 & A6	A6	A3
B3 & B6	B6	B3
A7 & A2	A2	A7
B7 & B2	B2	B7
A5 & A4	A4	A5
B5 & B4	B4	B5
A1 & A8	A1	A8
B1 & B8	B1	B8
A3 & A6	A3	A6
B3 & B6	B3	B6
A7 & A2	A7	A2
B7 & B2	B7	B2
A5 & A4	A5	A4
B5 & B4	B5	B4

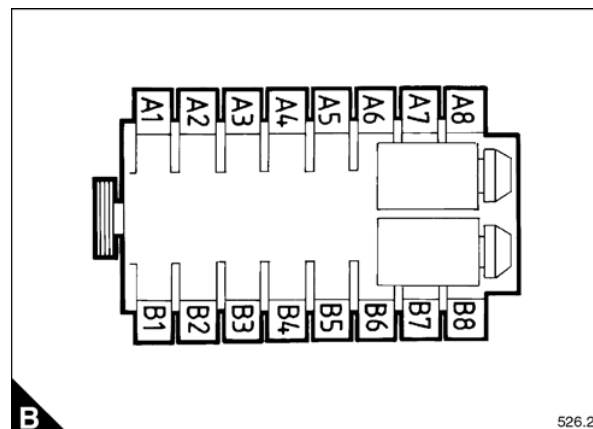
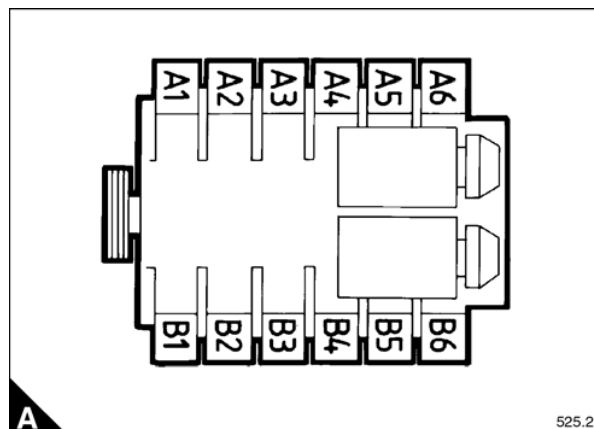

How to equalise bridge pieces

1 Rotate the engine to the position given in "Bridge piece and valve clearance setting sequence" on page 52.

Caution: Check the inlet and exhaust rockers have clearance on the bridge piece.

2 Loosen the locknut (A1) on the bridge piece.

3 Screw the adjuster (A2) out until the fixed side of the bridge piece rests on its valve.

4 Hold the top edge of the bridge piece and screw the adjuster down until it touches the valve.

5 Tighten the locknut to a torque of 35 Nm (25 lbf ft) without moving the adjuster.

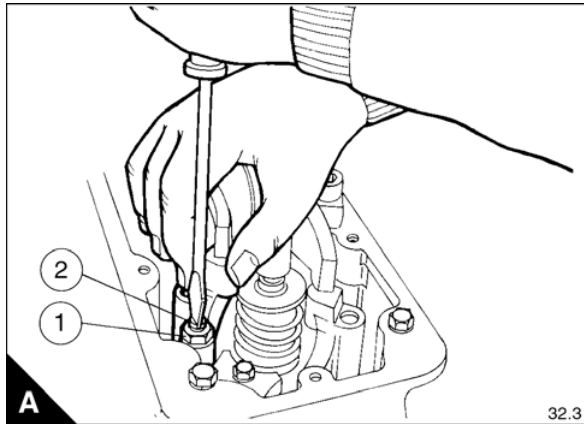

How to set valve clearances

Special requirements

Special tools	
Description	Part number
Feeler gauges	UA

1 Check the clearance using a feeler gauge (A1).

Note: The inlet and exhaust valve clearance is 0,4 mm (0.016").

2 To set the valve clearance loosen the locknut (A2).

3 Place the feeler gauge (A1) between the rocker and bridge piece.

4 Screw the adjuster (A3) up or down making the feeler gauge a slide fit.

5 Tighten the locknut to a torque of 50 Nm (35 lbf ft) without moving the adjuster.

6 Refit the rocker cover. Use a new gasket.

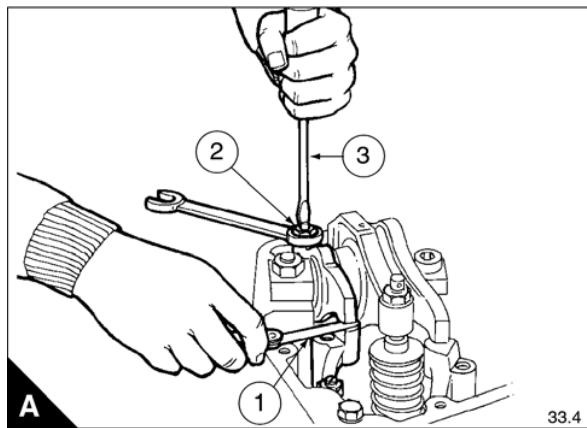

How to checking valve and seat recession

Special requirements

Special tools			
Description	Part number	Description	Part number
Valve seat recession checking tool	T6253/312	Feeler gauges	UA

By the use of tool No. T6253/312, an indication of valve and seat wear (recession) can be obtained without the removal of a cylinder head.

The tool is to be used as part of the bridge piece and valve clearance setting sequence.

Note: The inlet valves are easily checked but as there is insufficient clearance only one exhaust valve can be checked.

1 Place the tool on the rocker box face around the bolt (A1). Position the legs of the tool above the inlet valve spring retainers.

2 The clearance between the legs and valve spring retainers indicates the valve life left. A leg touching a valve spring retainer indicates the need for a cylinder head overhaul.

3 To check the exhaust valve, place the tool around bolt (A2).

From engine serial number DGK120717U0686F (12 cylinder engines) and DGR161221U0687F (16 cylinder engines) the following improvements have been introduced:

- The rocker box to cylinder head joint has been improved using a graphite material which is 0,7 mm thicker than the joint it has replaced.
- Capscrews have replaced the retaining bolts (A1) and (A2).

To check valve seat recession on these engines use a 0,7 mm feeler gauge (A3) in conjunction with the recession tool (A4).

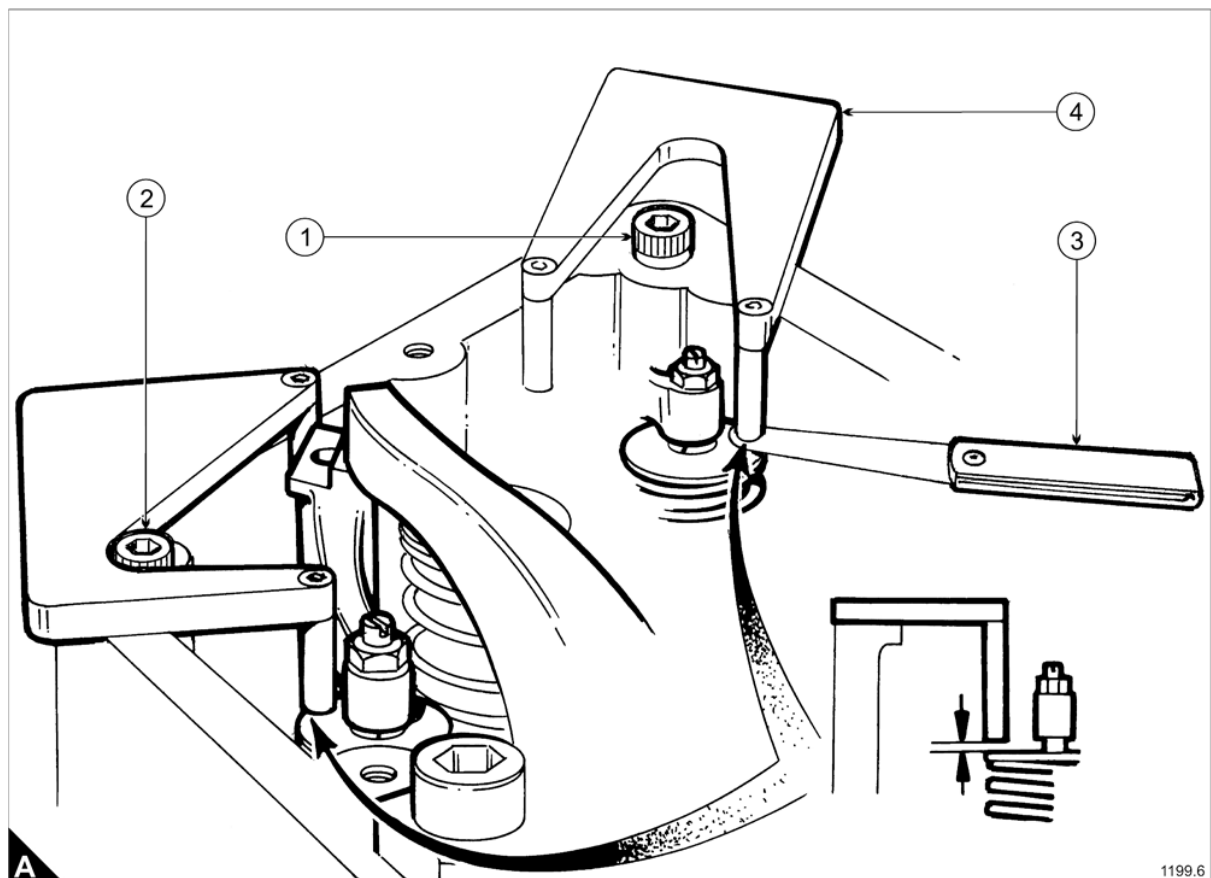

This page is intentionally blank

5

Engine fluids

Fuel specification

To get the correct power and performance from your engine, use good quality fuel.

Fuel should be wholly hydrocarbon oil derived from petroleum, with which small quantities of additives may be incorporated for the improvement of ignition or other characteristics and should conform to British Standard Specification 2869. Class A1 or A2, as detailed in the table below.

Note: If fuels other than the above classes are considered, the operator must consult Perkins Engines Company Limited, Stafford, and ensure that a suitable grade of lubricating oil is used.

BS2869 requirements for engine fuel

Property	Class A1	Class A2
Viscosity, kinematic at 40 °C, cSt ⁽¹⁾		
Minimum	1,5	1,5
Maximum	5,0	5,5
Cetane number, min.	50	45
Carbon residue, Ramsbottom on 10% residue, % (m/m), maximum	0,20	0,20
Distillation, recovery at 350 °C, % (V/V), min.	56 °C	56 °C
Water content, % (V/V), maximum.	0.05	0.05
Sediment, % (m/m), maximum.	0.01	0.01
Ash, % (m/m), maximum.	0.01	0.01
Sulphur content, % (m/m), maximum.	0.30 ⁽²⁾	0.50 ⁽²⁾
Copper corrosion test, maximum.	1	1
Cold filter plugging point °C, maximum.		
Summer (March/September inclusive) ⁽³⁾	-4	-4
Winter (October/February inclusive) ⁽³⁾	-15	-12

(1) 1cSt = 1 mm²/s.

(2) Applies to Northern Hemisphere only.

(3) This limit is set in accordance with the legislative requirements for gas oil of the 'Council Directive (75/716/EEC of the European Economic Community) on the approximation of the laws of Member States relating to the sulphur content of certain liquid fuels'. In countries where this legislation does not apply, it is permissible to run 4000 series engines on fuels with up to 1.0% sulphur.

Engine fuels

1 The two classes of fuel specified in the table are marketed specifically as oil engine fuels. Class A1 is of higher quality and is intended primarily as an automotive diesel fuel, whilst Class A2 is intended as a general purpose diesel fuel. Classes A1 and A2 are distillate grades and are so specified as to prevent the inclusion of residuum.

2 The specifications for Classes A1 and A2 include limits for cold filter plugging point chosen to cover seasonal requirements in the United Kingdom.

3 Ignition quality is specified in terms of cetane number, but the calculated cetane index is referred to as an alternative for routine purposes with fuels not containing ignition improver additives.

Note: If local supply problems dictate that fuels which fall outside the above specification are to be used, our Service Department must be consulted prior to use.

Lubricating oil recommendations

Type of oil

The industrial diesel engine should be lubricated with a good quality oil conforming to API CD or CCMC D4 specifications. All the major oil companies formulate oils to the above specifications.

Viscosity

Always ensure that the correct viscosity grade of oil is used for the temperature range in which the engine will be run, as detailed below:

SAE10W/30	In starting temperatures below -15 °C (without sump heater)
SAE15W/40	In starting temperatures from -15 °C to 0 °C
SAE30 ⁽¹⁾	In starting temperatures from 0 °C to 32 °C
SAE40 ⁽¹⁾	In starting temperatures above 32 °C

(1) Mobil Delvac Super 1300 SAE 15W/40 can be used as a suitable alternative.

Engine operation

Repeated cold starts should be avoided, as they will cause excessive dilution of the oil by fuel, requiring more frequent oil changes and dangerously lowering the flash point of the oil.

Should there be a lubricating oil supply problem, or if the fuel being used contains more than 0.5% sulphur, Perkins Engines Company Limited, Stafford must be consulted to give advice in selecting a suitable grade.

The following table gives details of some of the oils that meet the required specifications. Note that the brand names may change as oils are upgraded or reformulated.

An up-to-date list is maintained by Perkins Engines Company Limited, Stafford of major oil companies products and information, which can be obtained from the Service Department.

Caution: Failure to comply with these instructions will invalidate the warranty offered with the engine, as it may result in damage to the engine.

Approved industrial oil A1 specifications BSEN 590

Suitable for fuel to Class A2 specifications BS2869 Part 2.

Oil Company	Type
CASTROL	CRH/RX Super
ELF	Multiperfo XC
KUWAIT OIL Co	Q8 T400
MOBIL	Delvac 13
MOBIL	Delvac Super 1300 (15W/40)
SHELL	Rimula X
ESSO	Essolube XD 3+
TEXACO	Ursa Super LA

Oil change periods

For normal operation of the engine the oil should be changed every 250 hours or annually whichever is the sooner.

Under certain circumstances where a centrifugal oil filter is fitted to the engine and an oil analysis programme has been carried out with the oil supplier over a period of 1000 hours of engine operation, it may be possible to extend the oil change period up to maximum of 350 hours.

To achieve the extended oil change period, a centrifugal oil filter must be fitted and cleaned every 150/200 hours between routine oil changes, and at every oil change point i.e. 350 hours maximum.

As the oil deteriorates it is essential that the following parameters must not be exceeded at the oil change point:

- 1 The viscosity of the oil must not increase by more than 10cSt at 100 °C.
- 2 The total base number of the oil should not reduce to less than 50% of the value of new oil.
- 3 The flash point of the oil should exceed 180 °C.
- 4 The water content of the oil must not exceed 1%.
- 5 The fuel content of the oil must not exceed 1%.

Note: Oil samples should be taken from the mean sump oil level of the engine.

Coolant specification

50% inhibited ethylene glycol or 50% inhibited propylene glycol and 50% clean fresh water should be used.

For combined heat and power systems and where there is no likelihood of ambient temperature below 10 °C, then clean 'soft' water may be used, treated with 1% by volume of Perkins inhibitor in the cooling system.

The inhibitor is available in under Perkins part number OE 45350.

Maintenance of coolant

Warning! Always stop the engine and allow the pressurised system to cool before removing the filler cap. Avoid skin contact with the coolant mixture.

The coolant mixture should be changed at 8,000 hours or 12 months and checked at 2,000 hour intervals for the correct alkalinity level. The pH should not be above 7.5.

Note: A hydrometer only shows the proportion of ethylene glycol. This is not a measure of protection against corrosion.

Caution: Failure to follow the above recommendations may result in engine damage and will invalidate the engine warranty.

6

Fault diagnosis

Problems and possible causes

Problem	Possible causes	
	Checks by the user	Checks by the workshop personnel
The starter motor turns the engine too slowly	1, 2, 3, 4	
The engine does not start	5, 6, 7, 8, 9, 10, 12, 13, 14, 15, 17	37, 38, 42, 43, 44, 64, 65, 66
The engine is difficult to start	5, 7, 8, 9, 10, 11, 12, 13, 14, 15, 16, 17, 19	37, 38, 40, 42, 43, 44, 64
Not enough power	8, 9, 10, 11, 12, 13, 16, 8, 9, 20, 21	37, 38, 39, 42, 43, 44, 61, 63, 64, 65, 66
Misfire	8, 9, 10, 12, 13, 15, 20, 22	37, 38, 39, 40, 43, 64, 66
High fuel consumption	11, 13, 15, 17, 18, 19, 23, 22	37, 38, 39, 40, 42, 43, 44, 63, 64
Black exhaust smoke	11, 13, 15, 17, 19, 21, 22	37, 38, 39, 40, 42, 43, 44, 61, 63, 64
Blue or white exhaust smoke	4, 15, 21, 23	37, 38, 39, 42, 43, 44, 45, 52, 58, 62, 64, 66
The pressure of the low pressure lubricating oil system is too low	4, 24, 25, 26	46, 47, 48, 50, 51, 59,
The engine knocks	9, 13, 15, 17, 20, 22, 23	37, 40, 42, 44, 46, 52, 53, 60, 64, 65
The engine runs erratically	8, 9, 10, 11, 12, 13, 15, 16, 18, 20, 22, 23	38, 40, 44, 52, 60, 64, 65, 66
Vibration	13, 18, 20, 27, 28	38, 39, 40, 44, 52, 54, 64, 65, 66
The pressure of the low pressure lubricating oil system is too high	4, 25	49
The engine oil temperature is too high	11, 13, 15, 19, 27, 29, 30, 32, 65	37, 39, 52, 55, 56, 57, 64, 66
Crankcase pressure	31, 33	39, 42, 44, 45, 52
Bad compression	11, 22	37, 39, 40, 42, 43, 44, 45, 53, 60
The engine starts and stops	10, 11, 12	64, 65, 66
The pressure of the high pressure lubricating oil system is too low	4, 24, 25, 26	64, 65, 66

List of possible causes

- 1 Battery capacity low.
- 2 Bad electrical connections.
- 3 Fault in starter motor.
- 4 Wrong grade of lubricating oil.
- 5 Starter motor turns engine too slowly.
- 6 Fuel tank empty.
- 7 Spare.
- 8 Restriction in a fuel pipe.
- 9 Fault in fuel lift pump.
- 10 Dirty fuel filter element.
- 11 Restriction in air induction system.
- 12 Air in fuel system.
- 13 Fault in the fuel injector units.
- 14 Cold start system used incorrectly.
- 15 Fault in cold start system.
- 16 Restriction in fuel tank vent.
- 17 Wrong type or grade of fuel used.
- 18 Restricted movement of engine speed control.
- 19 Restriction in exhaust pipe.
- 20 Engine temperature is too high.
- 21 Engine temperature is too low.
- 22 Incorrect valve tip clearances.
- 23 Too much oil or oil of the wrong type is used in wet type air cleaner, if one is fitted.
- 24 Not enough lubricating oil in sump.
- 25 Defective gauge.
- 26 Dirty lubricating oil filter element.
- 27 Fan damaged.
- 28 Fault in engine mounting or flywheel housing.
- 29 Too much lubricating oil in sump.
- 30 Restriction in air or water passages of radiator.
- 31 Restriction in breather pipe.
- 32 Insufficient coolant in system.
- 33 Fault in exhauster.
- 34 Spare.
- 35 Spare.
- 36 Spare.
- 37 Valve timing is incorrect.
- 38 Bad compression.
- 39 Cylinder head gasket leaks.
- 40 Valves are not free.

Continued

-
- 41 Spare.
 - 42 Worn cylinder bores.
 - 43 Leakage between valves and seats.
 - 44 Piston rings are not free or they are worn or broken.
 - 45 Valve stems and/or guides are worn.
 - 46 Crankshaft bearings are worn or damaged.
 - 47 Lubricating oil pump is worn.
 - 48 Relief valve does not close.
 - 49 Relief valve does not open.
 - 50 Relief valve spring is broken.
 - 51 Fault in suction pipe of lubricating oil pump.
 - 52 Piston is damaged.
 - 53 Piston height is incorrect.
 - 54 Flywheel housing or flywheel is not aligned correctly.
 - 55 Fault in thermostat or thermostat is of an incorrect type.
 - 56 Restriction in coolant passages.
 - 57 Fault in water pump.
 - 58 Valve stem seal is damaged.
 - 59 Restriction in sump strainer.
 - 60 Valve spring is broken.
 - 61 Turbocharger impeller is damaged or dirty.
 - 62 Turbocharger lubricating oil seal leaking.
 - 63 Induction system leaks.
 - 64 Faulty engine management system
 - 65 Faulty injection control system
 - 66 Faulty sensor

This page is intentionally blank