

Wärtsilä 20

PRODUCT GUIDE

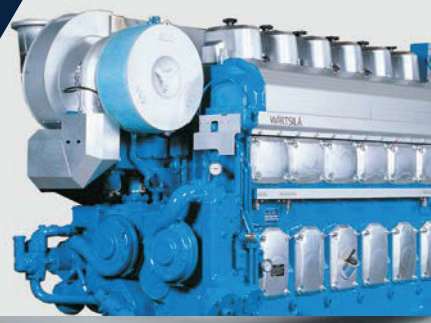

© Copyright by WÄRTSILÄ FINLAND OY

COPYRIGHT © 2019 by WÄRTSILÄ FINLAND OY

All rights reserved. No part of this booklet may be reproduced or copied in any form or by any means (electronic, mechanical, graphic, photocopying, recording, taping or other information retrieval systems) without the prior written permission of the copyright owner.

THIS PUBLICATION IS DESIGNED TO PROVIDE AN ACCURATE AND AUTHORITATIVE INFORMATION WITH REGARD TO THE SUBJECT-MATTER COVERED AS WAS AVAILABLE AT THE TIME OF PRINTING. HOWEVER, THE PUBLICATION DEALS WITH COMPLICATED TECHNICAL MATTERS SUITED ONLY FOR SPECIALISTS IN THE AREA, AND THE DESIGN OF THE SUBJECT-PRODUCTS IS SUBJECT TO REGULAR IMPROVEMENTS, MODIFICATIONS AND CHANGES. CONSEQUENTLY, THE PUBLISHER AND COPYRIGHT OWNER OF THIS PUBLICATION CAN NOT ACCEPT ANY RESPONSIBILITY OR LIABILITY FOR ANY EVENTUAL ERRORS OR OMISSIONS IN THIS BOOKLET OR FOR DISCREPANCIES ARISING FROM THE FEATURES OF ANY ACTUAL ITEM IN THE RESPECTIVE PRODUCT BEING DIFFERENT FROM THOSE SHOWN IN THIS PUBLICATION. THE PUBLISHER AND COPYRIGHT OWNER SHALL UNDER NO CIRCUMSTANCES BE HELD LIABLE FOR ANY FINANCIAL CONSEQUENTIAL DAMAGES OR OTHER LOSS, OR ANY OTHER DAMAGE OR INJURY, SUFFERED BY ANY PARTY MAKING USE OF THIS PUBLICATION OR THE INFORMATION CONTAINED HEREIN.

Introduction

This Product Guide provides data and system proposals for the early design phase of marine engine installations. For contracted projects specific instructions for planning the installation are always delivered. Any data and information herein is subject to revision without notice. This 1/2019 issue replaces all previous issues of the Wärtsilä 20 Project Guides.

Issue	Published	Updates
1/2019	12.07.2019	Technical data section updated, UNIC C1 added in Chapter Automation. Other minor updates throughout the product guide.
1/2018	7.11.2018	Technical data section updated (e.g. SCR, 1200 rpm and HFO Optimized engines added). Other minor updates throughout the product guide.
1/2017	14.02.2017	Technical data section updated. Other minor updates throughout the product guide.
1/2016	06.09.2016	Technical data section updated
1/2015	14.10.2015	Numerous updates throughout the product guide
1/2013	19.04.2013	Chapters Fuel Oil System and Lubrication Oil System updated with low sulphur operation, several other updates throughout the product guide.

Wärtsilä, Marine Solutions

Vaasa, July 2019

This page intentionally left blank

Table of contents

1. Main Data and Outputs	1-1
1.1 Technical main data	1-1
1.2 Maximum continuous output	1-1
1.3 Reference conditions	1-3
1.4 Operation in inclined position (only for Marine Business engines)	1-3
1.5 Principal dimensions and weights	1-4
2. Operating Ranges	2-1
2.1 Engine operating modes	2-1
2.2 Engine operating range	2-1
2.3 Loading capacity	2-8
2.4 Low load operation	2-13
2.5 Low air temperature	2-13
3. Technical Data	3-1
3.1 Introduction	3-1
3.2 Wärtsilä 4L20	3-1
3.3 Wärtsilä 6L20	3-8
3.4 Wärtsilä 8L20	3-20
3.5 Wärtsilä 9L20	3-32
4. Description of the Engine	4-1
4.1 Definitions	4-1
4.2 Main components and systems	4-1
4.3 Cross sections of the engine	4-4
4.4 Expected Technical Life Time	4-5
4.5 Engine storage	4-7
5. Piping Design, Treatment and Installation	5-1
5.1 Pipe dimensions	5-1
5.2 Trace heating	5-2
5.3 Pressure class	5-2
5.4 Pipe class	5-3
5.5 Insulation	5-4
5.6 Local gauges	5-4
5.7 Cleaning procedures	5-4
5.8 Flexible pipe connections	5-5
5.9 Clamping of pipes	5-7
6. Fuel Oil System	6-1
6.1 Acceptable fuel characteristics	6-1
6.2 Internal fuel oil system	6-14
6.3 External fuel oil system	6-17
7. Lubricating Oil System	7-1
7.1 Lubricating oil requirements	7-1
7.2 Internal lubricating oil system	7-2
7.3 External lubricating oil system	7-6
7.4 Crankcase ventilation system	7-12
7.5 Flushing instructions	7-14
8. Compressed Air System	8-1
8.1 Internal compressed air system	8-1

8.2 External compressed air system	8-4
9. Cooling Water System	9-1
9.1 Water quality	9-1
9.2 Internal cooling water system	9-2
9.3 External cooling water system	9-7
10. Combustion Air System	10-1
10.1 Engine room ventilation	10-1
10.2 Combustion air system design	10-3
11. Exhaust Gas System	11-1
11.1 Internal exhaust gas system	11-1
11.2 Temperature sensor location after Turbocharger	11-3
11.3 Exhaust gas outlet	11-4
11.4 External exhaust gas system	11-6
12. Turbocharger Cleaning	12-1
12.1 Turbine cleaning system	12-1
12.2 Compressor cleaning system	12-1
13. Exhaust Emissions	13-1
13.1 Diesel engine exhaust components	13-1
13.2 Marine exhaust emissions legislation	13-2
13.3 Methods to reduce exhaust emissions	13-2
14. Automation System	14-1
14.1 UNIC C1	14-1
14.2 UNIC C2	14-7
14.3 UNIC 2nd Generation	14-16
15. Foundation	15-1
15.1 Steel structure design	15-1
15.2 Mounting of main engines	15-1
15.3 Mounting of generating sets	15-6
15.4 Flexible pipe connections	15-8
16. Vibration and Noise	16-1
16.1 External forces & couples	16-1
16.2 Mass moments of inertia	16-5
16.3 Structure borne noise	16-5
16.4 Air borne noise	16-6
16.5 Exhaust noise	16-7
17. Power Transmission	17-1
17.1 Flexible coupling	17-1
17.2 Clutch	17-2
17.3 Shaft locking device	17-2
17.4 Power-take-off from the free end	17-3
17.5 Input data for torsional vibration calculations	17-4
17.6 Turning gear	17-5
18. Engine Room Layout	18-1
18.1 Crankshaft distances	18-1
18.2 Space requirements for maintenance	18-3
18.3 Transportation and storage of spare parts and tools	18-3
18.4 Required deck area for service work	18-4

19. Transport Dimensions and Weights	19-1
19.1 Lifting of engines	19-1
19.2 Engine components	19-3
20. Product Guide Attachments	20-1
21. ANNEX	21-1
21.1 Unit conversion tables	21-1
21.2 Collection of drawing symbols used in drawings	21-2

This page intentionally left blank

1. Main Data and Outputs

1.1 Technical main data

The Wärtsilä 20 is a 4-stroke, non-reversible, turbocharged and intercooled diesel engine with direct injection of fuel.

Cylinder bore	200 mm
Stroke	280 mm
Piston displacement	8.8 l/cyl
Number of valves	2 inlet valves and 2 exhaust valves
Cylinder configuration	4, 6, 8, 9, in-line
Direction of rotation	Clockwise, counterclockwise on request
Speed	900, 1000, 1200 rpm
Mean piston speed	8.4, 9.3, 11,2 m/s

1.2 Maximum continuous output

1.2.1 Rated output

The engine is available in 1200 and 1000 rpm versions for propeller propulsion and for electric propulsion 1200, 1000 and 900 rpm.

1.2.1.1 Diesel electric propulsion, constant speed

Table 1-1 Output tables (kW)

Engine	1200 rpm	1000 rpm	900 rpm
4L20	-	800	740
6L20	1320	1200	1110
8L20	1760	1600	1480
9L20	1980	1800	1665

Outputs are given in kW at flywheel, including or excluding engine driven pumps, ISO 15550 - 2002 (E) conditions.

1.2.1.2 Mechanical controllable pitch propeller propulsion, variable speed

Table 1-2 Output tables (kW)

Engine	1200 rpm	1000 rpm
4L20	-	800
6L20	1320	1200

Engine	1200 rpm	1000 rpm
8L20	1760	1600
9L20	1980	1600

Outputs are given in kW at flywheel, including or excluding engine driven pumps, ISO 15550 - 2002 (E) conditions.

1.2.2 Rated Output - Auxiliary Engines

Table 1-3 Output tables (kW)

Engine	1200 rpm	1000 rpm	900 rpm
4L20	-	800	740
6L20	1320	1200	1110
8L20	1760	1600	1480
9L20	1980	1800	1665

Outputs are given in kW at flywheel, including or excluding engine driven pumps, ISO 15550 - 2002 (E) conditions.

The mean effective pressure P_e can be calculated as follows:

$$P_e = \frac{P \times c \times 1.2 \times 10^9}{D^2 \times L \times n \times \pi}$$

where:

P_e = Mean effective pressure [bar]

P = Output per cylinder [kW]

n = Engine speed [r/min]

D = Cylinder diameter [mm]

L = Length of piston stroke [mm]

c = Operating cycle (4)

1.3 Reference conditions

The output is available up to an air temperature of max. 45°C. For higher temperatures, the output has to be reduced according to the formula stated in ISO 3046-1:2002 (E).

The specific fuel oil consumption is stated in the chapter *Technical data*. The stated specific fuel oil consumption applies to engines with engine driven pumps, operating in ambient conditions according to ISO 15550:2002 (E). The ISO standard reference conditions are:

total barometric pressure	100 kPa
air temperature	25 °C
relative humidity	30 %
charge air coolant temperature	25 °C

Correction factors for the fuel oil consumption in other ambient conditions are given in standard ISO 15550:2002 (E).

1.4 Operation in inclined position (only for Marine Business engines)

The engine is designed to ensure proper engine operation at inclination positions, specified under IACS M46.2 (1982) (Rev.1 June 2002) - Main and auxiliary machinery.

Max. inclination angles at which the engine will operate satisfactorily:

- Permanent athwart ship inclinations (list) 15°
- Temporary athwart ship inclinations (roll) 22.5°
- Permanent fore-and-aft inclinations (trim) 5°
- Temporary fore and aft inclinations (pitch) 7.5°

Inclination in all directions requires special arrangements.

NOTE



- Athwartships and fore-end-aft inclinations may occur simultaneously
- Inclination angles are applicable ONLY to marine main and auxiliary machinery engines. Emergency power installations are not currently available
- If inclination exceeds some of the above mentioned IACS requirements, a special arrangement might be needed. Please fill in a NSR (Non-standard request)

1.5 Principal dimensions and weights

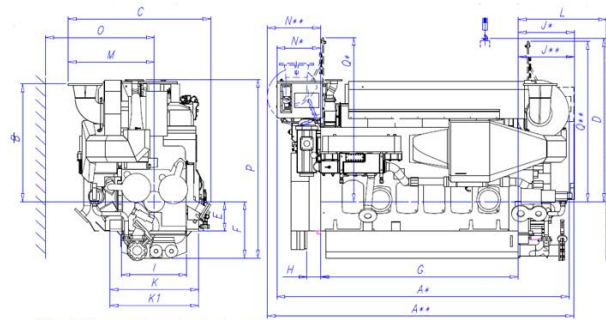

- 1) Auxiliary engine (normal sump)
- 2) Main engine (deep sump)
- 3) HFO fuel
- 4) LFO fuel

- *Turbocharger at free end
- **Turbocharger at flywheel end

Engine	UNIC C1		UNIC C2		UNIC 2.0		B*	B**	C*	C**	D	E	F	G	H	I	J*	J**	J***	K	K1	L	M*	M**	N*	N**
	A*	A**	A**	A***	A**	A***																				
4L20	2689	2884	3389	3503	1168	1299	1528	1800	325	725	1480	155	718	723	723	834	980	1140	700	854	951	485	681	485	681	589
6L20	3285	3484	4120	4222	1390	1614	1800	325	725	2080	155	718	723	723	834	980	1140	1000	950	951	485	681	485	681	708	
8L20	3897	4091	4120	4222	1390	1614	1800	325	725	2680	155	718	730	723	834	980	1140	1300	1084	1127	485	681	485	681	708	
9L20	4200	4395	4421	4519	1390	1614	1800	325	725	2980	155	718	734	723	834	980	1140	1300	1084	1127	485	681	485	681	696	

Engine	UNIC C1		UNIC C2		UNIC 2.0		Q*	Q**	Q***
	0	0	P*	P**	P*	P**			
4L20	1200	1320	2252	2211	1809	2120	2015	1980	
6L20	1200	1320	2110	2352	1809	2120	1767	2015	
8L20	1200	1320	2110	2440	1809	2120	1767	2015	
9L20	1200	1320	2110	2440	1809	2120	1767	2015	

Fig 1-1 Main Engines (DAAE060842C) - UNIC C1, UNIC C2 & UNIC 2.0

A	TOTAL LENGTH OF THE ENGINE
B	HEIGHT FROM THE CRANKSHAFT CENTERLINE TO THE EXHAUST GAS OUTLET
C	TOTAL WIDTH OF THE ENGINE
D	MINIMUM HEIGHT WHEN REMOVING A PISTON
E	HEIGHT FROM THE CRANKSHAFT CENTERLINE TO THE ENGINE FEET
F	DIMENSION FROM THE CRANKSHAFT CENTERLINE TO THE BOTTOM OF THE OIL SUMP
G	LENGTH OF THE ENGINE BLOCK
H	DIMENSION FROM THE END OF THE ENGINE BLOCK TO MOUNTING FACE FOR FLYWHEEL ON THE CRANKSHAFT
I	WIDTH OF THE OIL SUMP
J	FROM THE ENGINE BLOCK TO THE OUTERMOST FREE END
K	WIDTH OF THE ENGINE AT THE ENGINE FEET, FIXED MOUNTING
K1	WIDTH OF THE ENGINE AT THE ENGINE FEET, FLEXIBLE MOUNTING
L	CAMSHAFT OVERHAUL DISTANCE
M	DIMENSION FROM THE CENTER OF THE CRANKSHAFT TO THE OUTERMOST PART ON THE BACK SIDE OF THE ENGINE
N	FROM THE ENGINE BLOCK TO THE OUTERMOST PART AT THE FLYWHEEL END
O	CHARGE AIR COOLER OVERHAUL DISTANCE
P	TOTAL HEIGHT OF THE ENGINE
Q	HEIGHT FOR THE DOOR ON THE CONNECTING BOX, FROM CRANKSHAFT CENTERLINE

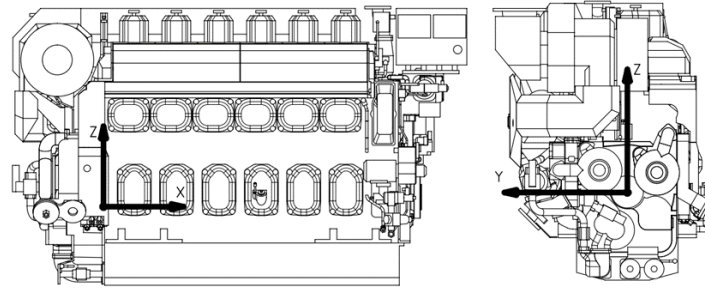

Weights are approx. and should be used only for guidance. Weights may vary due to followings:

- Turbocharger type/ brand
- Turbocharger w. Silencer or suction air pipe
- Oil sump i.e. normal or deep
- Pre-lubrication pump/electric motor type
- With/ without engine driven fuel pump
- Casting variations

Estimated tolerance: +2.5%
 *Values from analysis
 **Values calculated based on engines w. UNIC C2

Unic C1 / Unic C2 AUTOMATION SYSTEM

Moottorityyppi ENGINE TYPE	Turboahlinen sijainti TURBOCHARGER LOCATION	Käiväpaino DRY WEIGHT Ilman vauhtipyörää WITHOUT FLYWHEEL kg (average)	Nesteen massa WEIGHT OF LIQUIDS Öljy + jäähdytysvesi OIL + COOLING WATER kg (approx.)	Massakeskipiste CENTRE OF GRAVITY		
				X (mm)	Y (mm)	Z (mm)
4L20LF	Free end	6600	With dry sump, running condition 100 Wet sump 400	632	77	341
6L20LF	Free end	8100	With dry sump, running condition 115 Wet sump 465	900	76	341
6L20LD	Driving end	8500	Deep sump 645	987	78	341
8L20LF	Free end	10300	With dry sump, running condition 145 Wet sump 585	1186	76	341
8L20LD	Driving end	10400	Deep sump 825	1329	77	341
9L20LF	Free end	11100	With dry sump, running condition 165 Wet sump 660	1333	70	341
9L20LD	Driving end	10900 *	Deep sump 925	1480	-	341

** UNIC 2.0 AUTOMATION SYSTEM

Moottorityyppi ENGINE TYPE	Turboahlinen sijainti TURBOCHARGER LOCATION	Käiväpaino DRY WEIGHT Ilman vauhtipyörää WITHOUT FLYWHEEL kg (average)	Nesteen massa WEIGHT OF LIQUIDS Öljy + jäähdytysvesi OIL + COOLING WATER kg (approx.)	Massakeskipiste CENTRE OF GRAVITY		
				X (mm)	Y (mm)	Z (mm)
4L20LF	Free end	6800	With dry sump, running condition 100 Wet sump 400	658	77	352
6L20LF	Free end	8300	With dry sump, running condition 115 Wet sump 465	926	77	350
6L20LD	Driving end	8700	Deep sump 645	966	82	348
8L20LF	Free end	10500	With dry sump, running condition 145 Wet sump 585	1211	77	348
8L20LD	Driving end	10600	Deep sump 825	1307	80	347
9L20LF	Free end	11300	With dry sump, running condition 165 Wet sump 660	1358	71	348
9L20LD	Driving end	11100	Deep sump 925	1457	-	346

Fig 1-2 Engine Weight (V92E0066F) - UNIC C1, UNIC C2 & UNIC 2.0

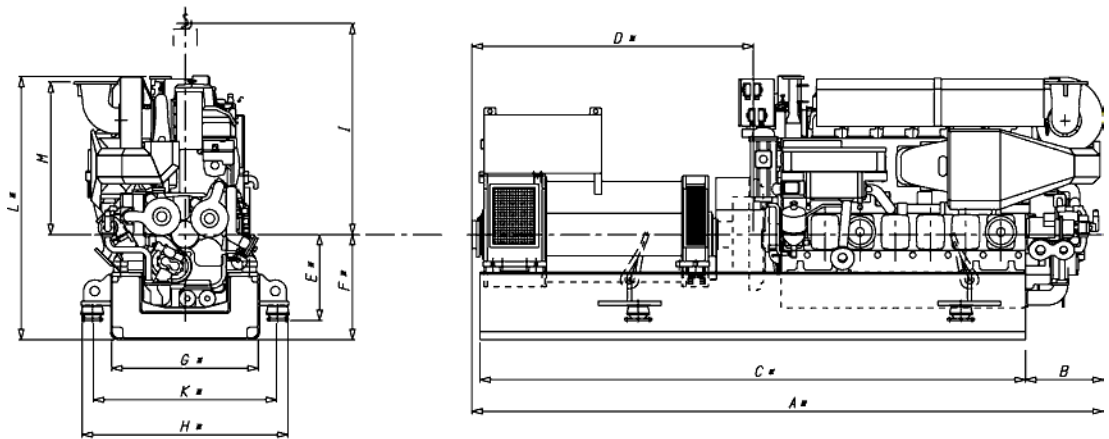

Fig 1-3 **Generating sets (V58E0576D)**

Engine	A*	B	C*	D*	E*	F*	G*	H*	I	K*	L*	M	Weight*
W 4L20	4910	665	4050	2460	725	990	1270/1420	1770/1920	1800	1580/1730	2338	1168	14.0
W 6L20	5325	663	4575	2300	725	895/975/1025	1270/1420/1570	1770/1920/2070	1800	1580/1730/1880	2243/2323/2373	1299	16.8
W 8L20	6030	731	5100	2310	725	1025/1075	1420/1570	1920/2070	1800	1730/1880	2474/2524	1390	20.7
W 9L20	6535	731	5400	2580	725	1075/1125	1570/1800	2070/2300	1800	1880/2110	2524/2574	1390	23.8

* Dependent on generator type and size.
 Dimensions in mm. Weight in tons.

NOTE

i
 Generating set dimensions (V58E0576D) shown above are for reference ONLY.

2. Operating Ranges

2.1 Engine operating modes

If the engine is configured for Selective Catalytic Reduction (SCR) use then it can be operated in two modes; IMO Tier 2 mode and SCR mode. The mode can be selected by an input signal to the engine automation system.

In SCR mode the exhaust gas temperatures after the turbocharger are actively monitored and adjusted to stay within the operating temperature window of the SCR.

2.2 Engine operating range

Running below nominal speed the load must be limited according to the diagrams in this chapter in order to maintain engine operating parameters within acceptable limits. Operation in the shaded area is permitted only temporarily during transients. Minimum speed is indicated in the diagram, but project specific limitations may apply.

2.2.1 Controllable pitch propellers

An automatic load control system is required to protect the engine from overload. The load control reduces the propeller pitch automatically, when a pre-programmed load versus speed curve ("engine limit curve") is exceeded, overriding the combinator curve if necessary. The engine load is derived from fuel rack position and actual engine speed (not speed demand).

The propeller efficiency is highest at design pitch. It is common practice to dimension the propeller so that the specified ship speed is attained with design pitch, nominal engine speed and 85% output in the specified loading condition. The power demand from a possible shaft generator or PTO must be taken into account. The 15% margin is a provision for weather conditions and fouling of hull and propeller. An additional engine margin can be applied for most economical operation of the engine, or to have reserve power.

The propulsion control must also include automatic limitation of the load increase rate. Maximum loading rates can be found later in this chapter.

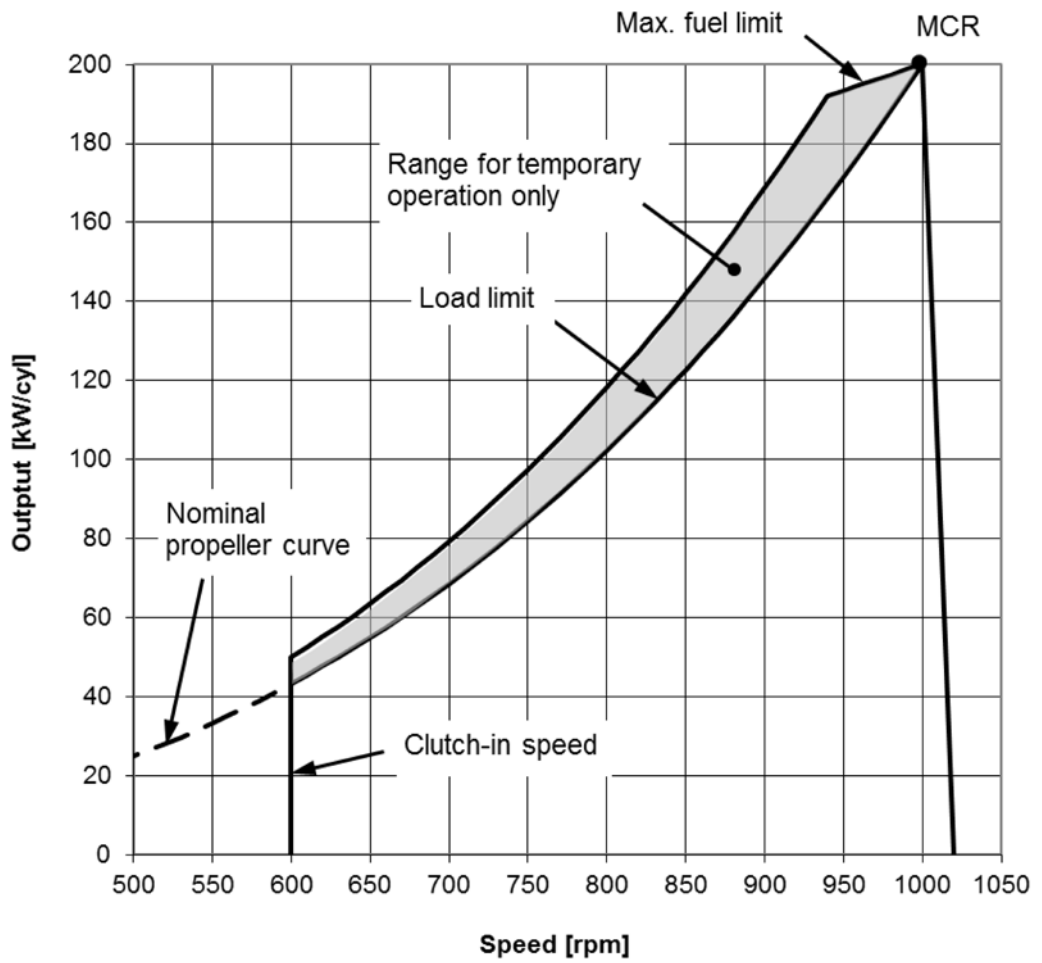

Fig 2-1 Operating field - CP Propeller 1000 rpm (DAAF007339B)

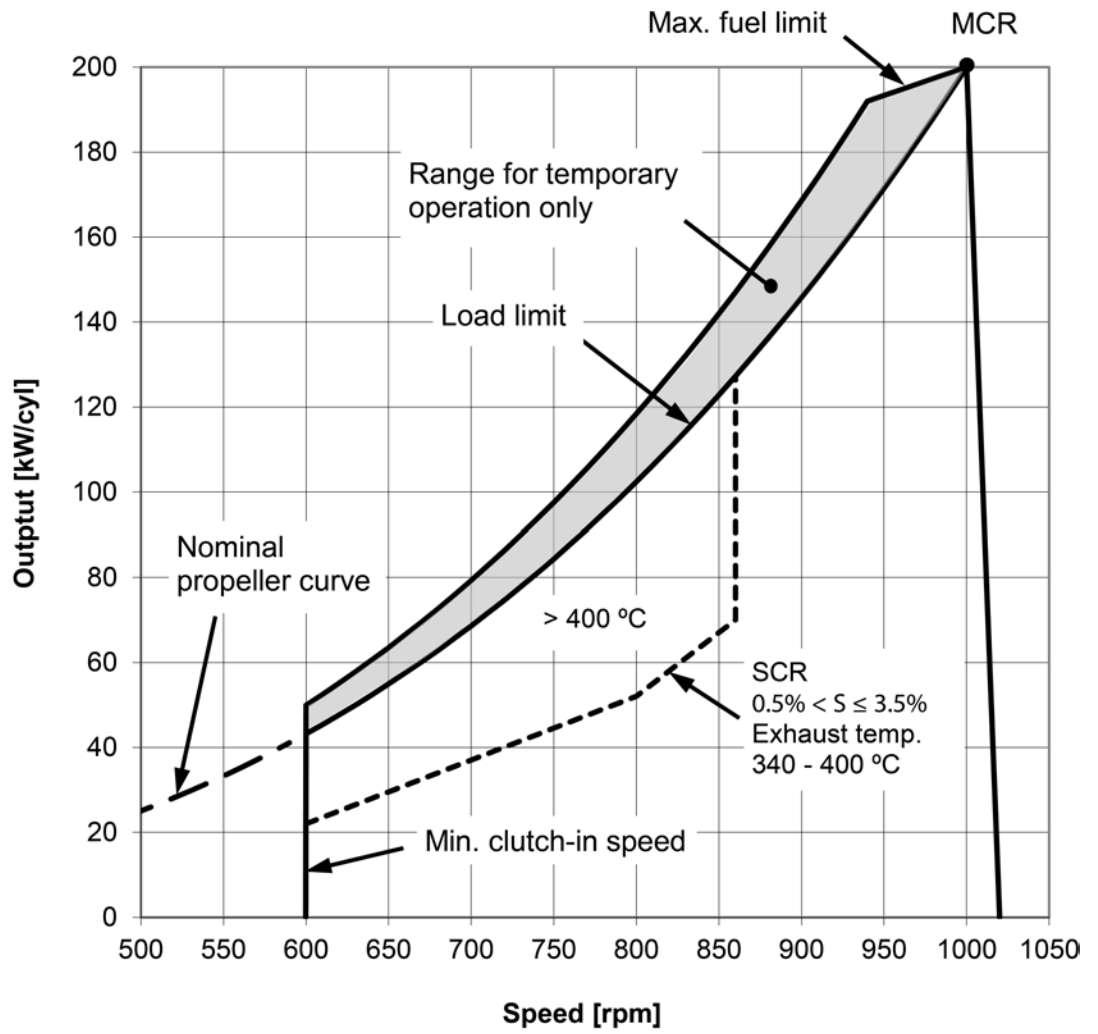

Fig 2-2 Operating field - CP Propeller 1000 rpm SCR with sulphur content $0,5\% < S \leq 3,5\%$ (DAAF360481C)

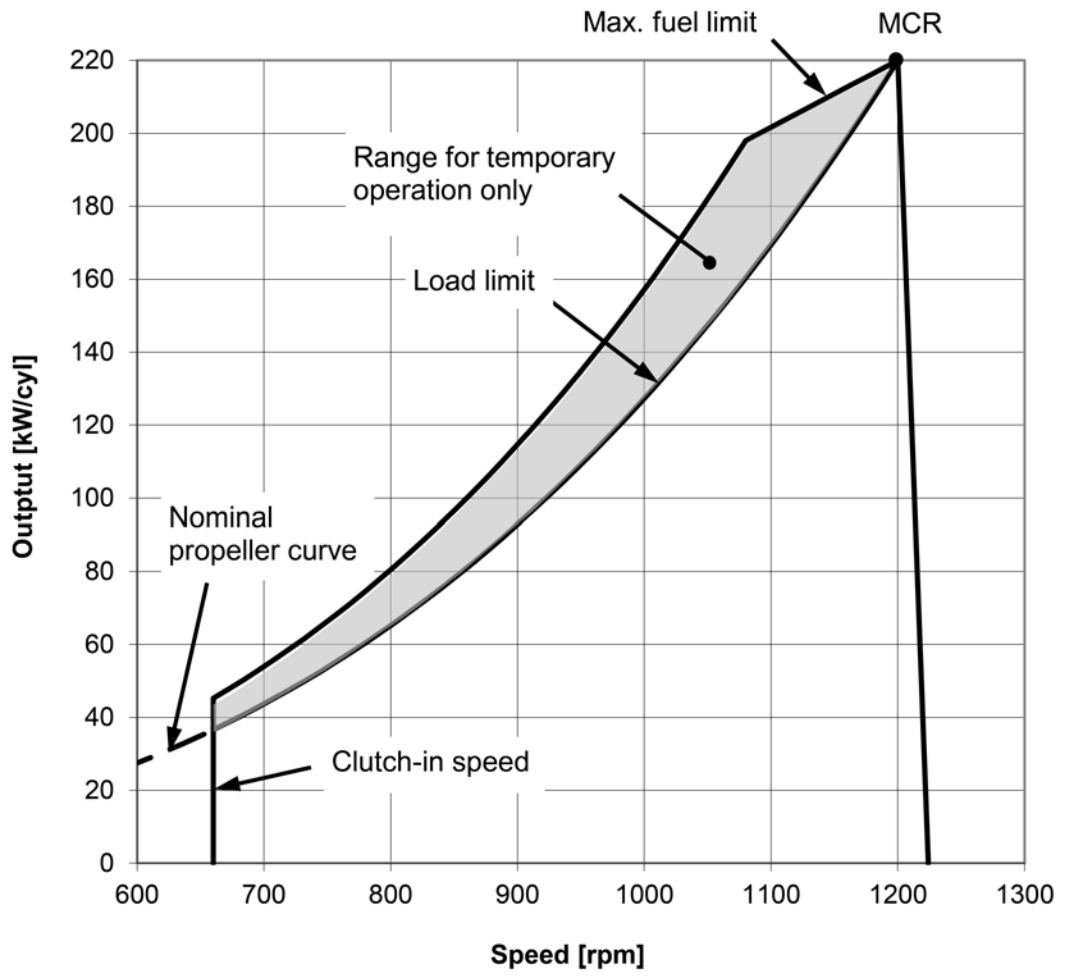

Fig 2-3 Operating field - CP Propeller 1200 rpm (DAAF437248)

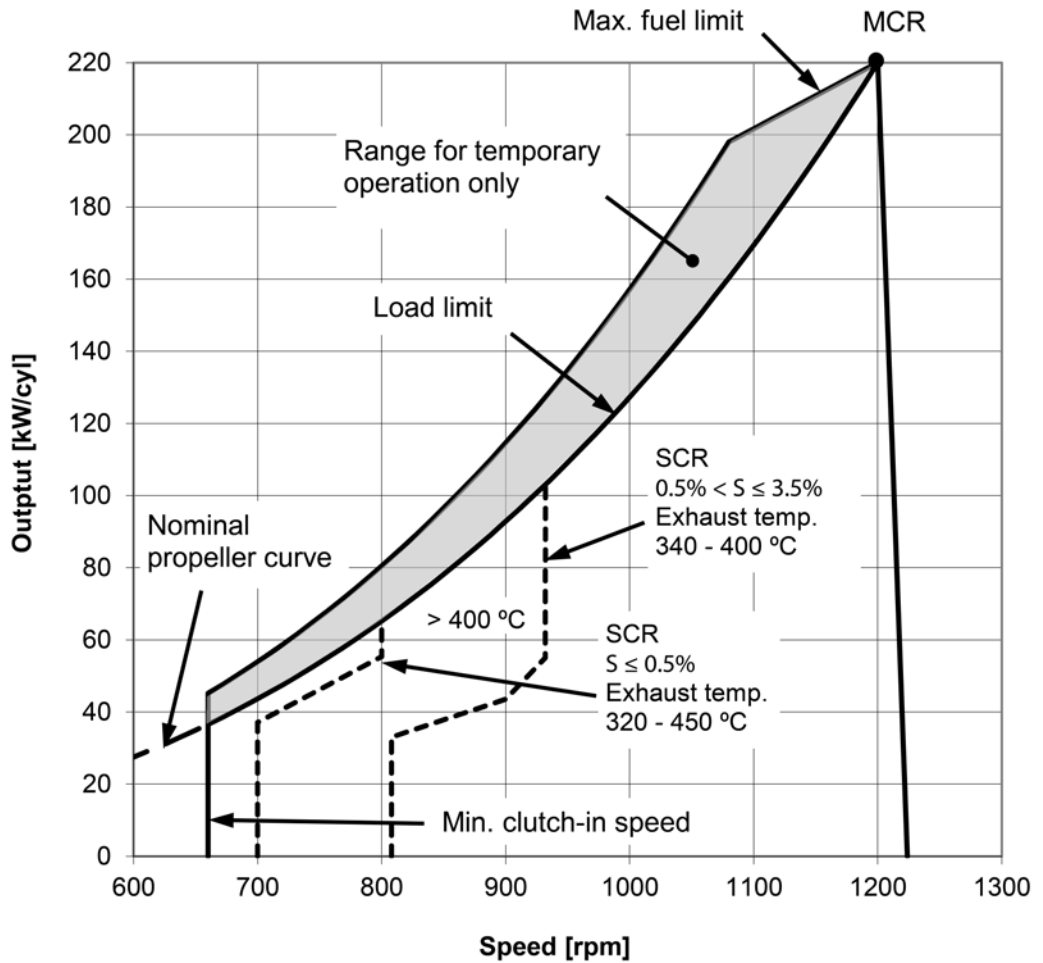

Fig 2-4 Operating field - CP Propeller 1200 rpm SCR with sulphur content $S \leq 0,5\%$ and $0,5\% < S \leq 3,5\%$ (DAAF424192A)

NOTE	
i	MCR = Maximum Continuous Rating CSR = Continuous Service Rating Allowed for W20 with SCR at 45 °C suction air temperature.

2.2.2 Fixed pitch propellers

The thrust and power absorption of a given fixed pitch propeller is determined by the relation between ship speed and propeller revolution speed. The power absorption during acceleration, manoeuvring or towing is considerably higher than during free sailing for the same revolution speed. Increased ship resistance, for reason or another, reduces the ship speed, which increases the power absorption of the propeller over the whole operating range.

Loading conditions, weather conditions, ice conditions, fouling of hull, shallow water, and manoeuvring requirements must be carefully considered, when matching a fixed pitch propeller to the engine. The nominal propeller curve shown in the diagram must not be exceeded in

service, except temporarily during acceleration and manoeuvring. A fixed pitch propeller for a free sailing ship is therefore dimensioned so that it absorbs max. 85% of the engine output at nominal engine speed during trial with loaded ship. Typically this corresponds to about 82% for the propeller itself.

If the vessel is intended for towing, the propeller is dimensioned to absorb 95% of the engine power at nominal engine speed in bollard pull or towing condition. It is allowed to increase the engine speed to 101.7% in order to reach 100% MCR during bollard pull.

A shaft brake should be used to enable faster reversing and shorter stopping distance (crash stop). The ship speed at which the propeller can be engaged in reverse direction is still limited by the windmilling torque of the propeller and the torque capability of the engine at low revolution speed.

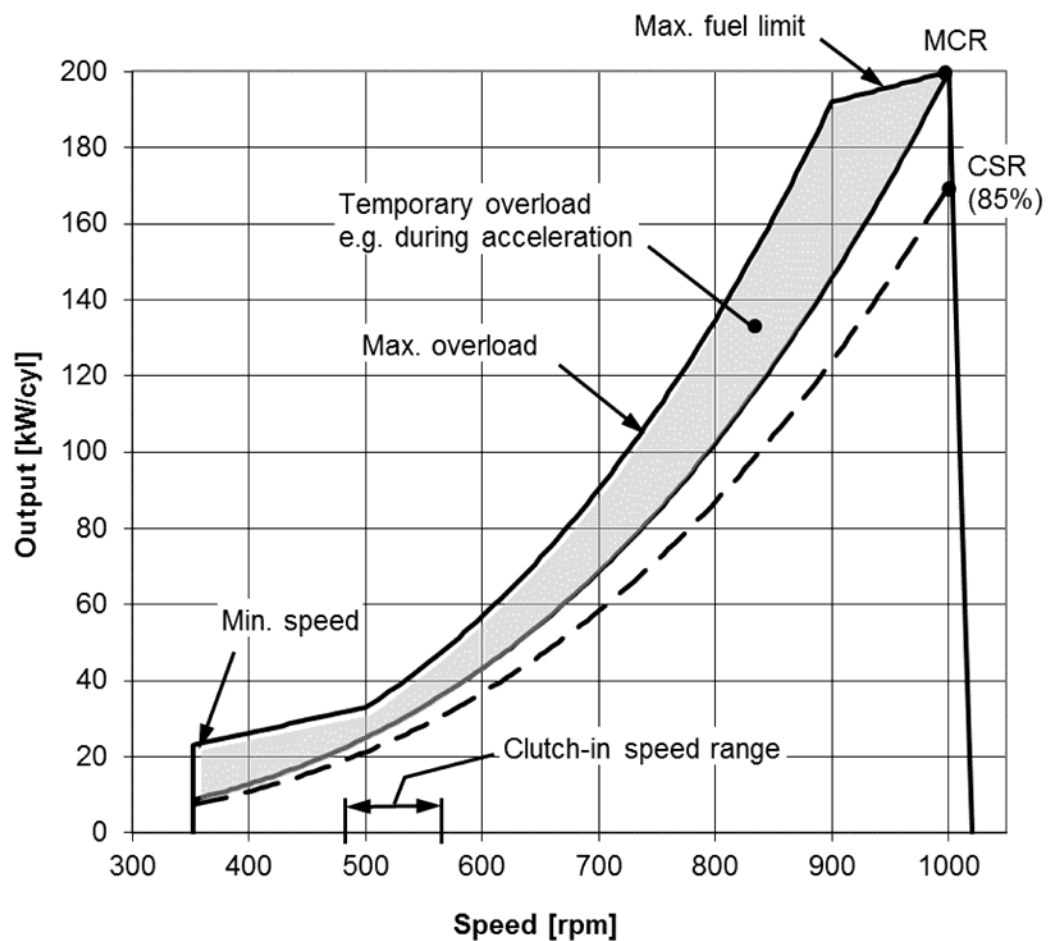

Fig 2-5 Operating field - FP Propeller 1000 rpm (DAAF007340B)

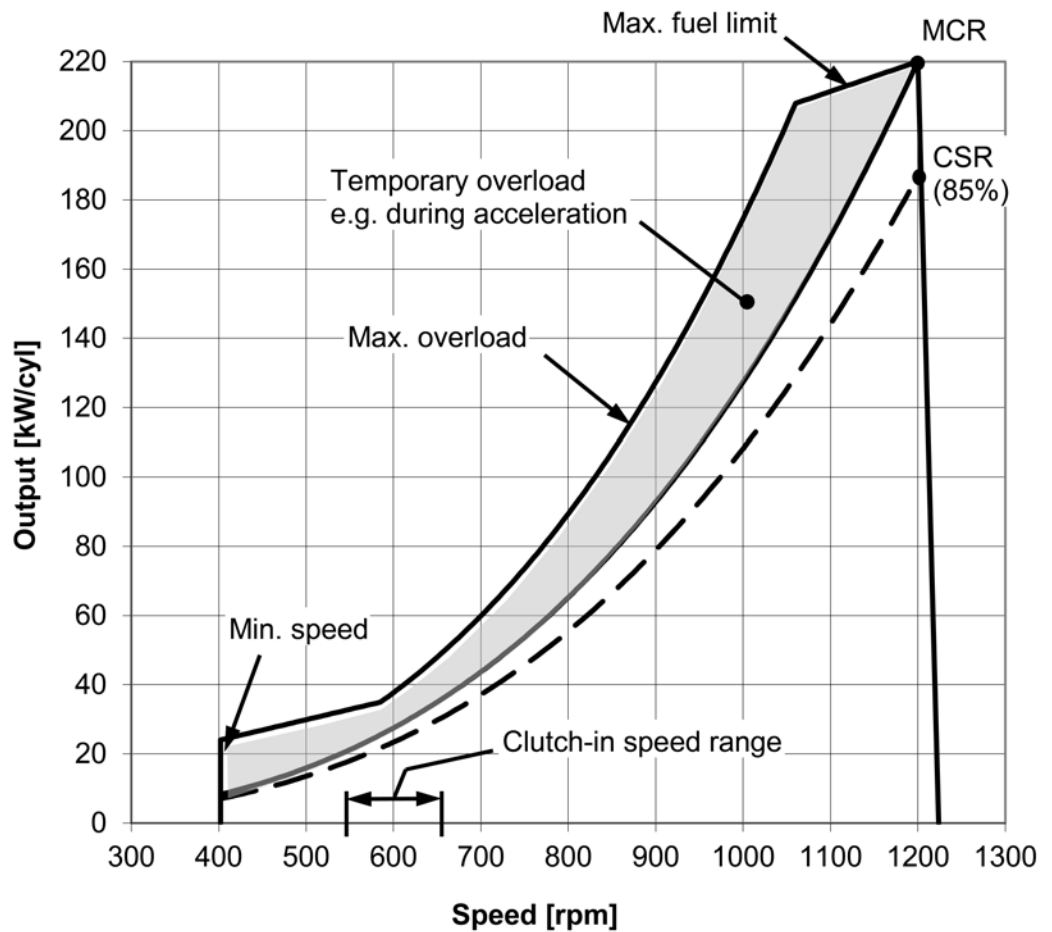

Fig 2-6 Operating field - FP Propeller 1200 rpm (DAAF437249)

MCR = Maximum Continuous Rating

CSR = Continuous Service Rating

2.2.2.1 FP propellers in twin screw vessels

Requirements regarding manoeuvring response and acceleration, as well as overload with one engine out of operation must be very carefully evaluated if the vessel is designed for free sailing, in particular if open propellers are applied. If the bollard pull curve significantly exceeds the maximum overload limit, acceleration and manoeuvring response can be very slow. Nozzle propellers are less problematic in this respect.

2.2.3 Dredgers

Mechanically driven dredging pumps typically require a capability to operate with full torque down to 80% of nominal engine speed. This requirement results in significant de-rating of the engine.

2.3 Loading capacity

Controlled load increase is essential for highly supercharged diesel engines, because the turbocharger needs time to accelerate before it can deliver the required amount of air. A slower loading ramp than the maximum capability of the engine permits a more even temperature distribution in engine components during transients.

The engine can be loaded immediately after start, provided that the engine is pre-heated to a HT-water temperature of 60...70°C, and the lubricating oil temperature of 30...40 °C.

The ramp for normal loading applies to engines that have reached normal operating temperature.

2.3.1 Mechanical propulsion

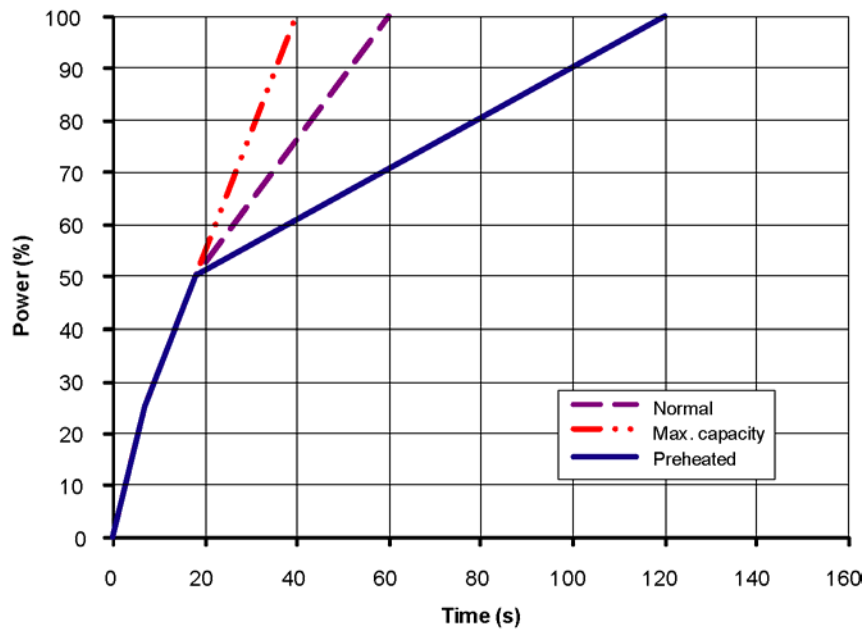

Fig 2-7 Maximum recommended load increase rates for variable speed engines

The propulsion control must include automatic limitation of the load increase rate. If the control system has only one load increase ramp, then the ramp for a preheated engine should be used. In tug applications the engines have usually reached normal operating temperature before the tug starts assisting. The “emergency” curve is close to the maximum capability of the engine.

If minimum smoke during load increase is a major priority, slower loading rate than in the diagram can be necessary below 50% load.

Large load reductions from high load should also be performed gradually. In normal operation the load should not be reduced from 100% to 0% in less than 15 seconds. When absolutely necessary, the load can be reduced as fast as the pitch setting system can react (overspeed due to windmilling must be considered for high speed ships).

2.3.2 Diesel electric propulsion and auxiliary engines

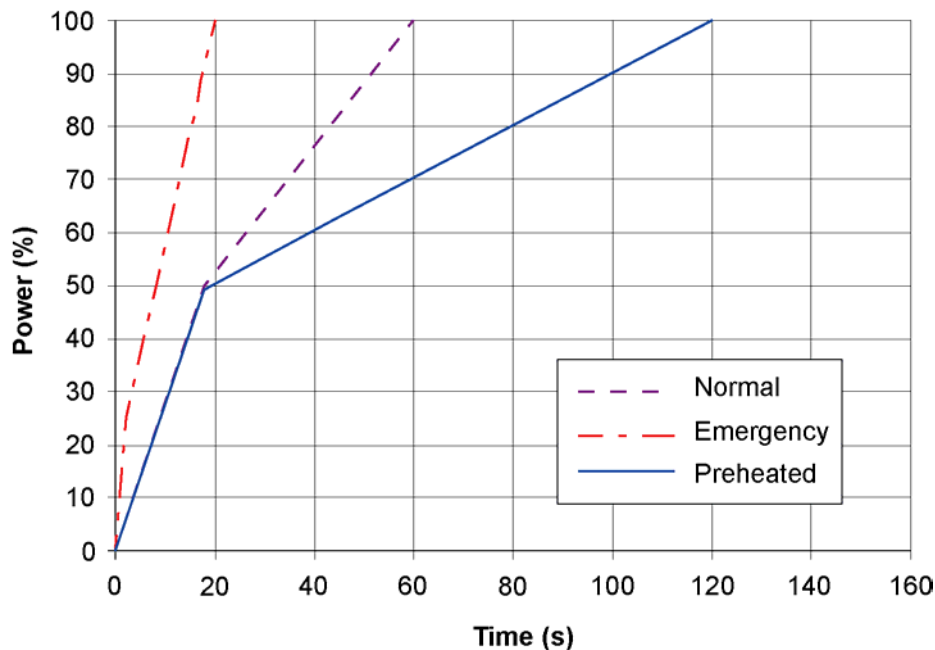

Fig 2-8 Maximum recommended load increase rates for engines operating at nominal speed

In diesel electric installations loading ramps are implemented both in the propulsion control and in the power management system, or in the engine speed control in case isochronous load sharing is applied. If a ramp without knee-point is used, it should not achieve 100% load in shorter time than the ramp in the figure. When the load sharing is based on speed droop, the load increase rate of a recently connected generator is the sum of the load transfer performed by the power management system and the load increase performed by the propulsion control.

The “emergency” curve is close to the maximum capability of the engine and it shall not be used as the normal limit. In dynamic positioning applications loading ramps corresponding to 20-30 seconds from zero to full load are however normal. If the vessel has also other operating modes, a slower loading ramp is recommended for these operating modes.

In typical auxiliary engine applications there is usually no single consumer being decisive for the loading rate. It is recommended to group electrical equipment so that the load is increased in small increments, and the resulting loading rate roughly corresponds to the “normal” curve.

In normal operation the load should not be reduced from 100% to 0% in less than 15 seconds. If the application requires frequent unloading at a significantly faster rate, special arrangements can be necessary on the engine. In an emergency situation the full load can be thrown off instantly.

2.3.2.1 Maximum instant load steps

The electrical system must be designed so that tripping of breakers can be safely handled. This requires that the engines are protected from load steps exceeding their maximum load acceptance capability. The maximum permissible load step is 33% MCR for an engine without SCR and 25% MCR if the engine is equipped with an SCR. The resulting speed drop is less than 10% and the recovery time to within 1% of the steady state speed at the new load level is max. 5 seconds.

When electrical power is restored after a black-out, consumers are reconnected in groups or in a fast sequence with few generators on the busbar, which may cause significant load steps.

The engine must be allowed to recover for at least 7 seconds before applying the following load step, if the load is applied in maximum steps.

Maximum load steps, DME and AUX engines

ENGINES WITHOUT SCR (Tier2)

Instant Load Application

- Maximum load step according to figure below (0 – 33 – 66 – 100 %)
- Maximum transient speed decrease of 10 % of rated speed
- Steady-state frequency band ± 1.0 %
- Steady-state recovery time ≤ 5 sec.
- Time between load steps ≥ 5 sec., however the max. load limit specified in the graph below should not be exceeded

Engine unloading

- Instant load rejection 100 % - 0 %
- Maximum transient speed increase of 10 % of the rated speed
- Steady-state frequency band ± 1.0 %
- Steady-state recovery time ≤ 5 sec.

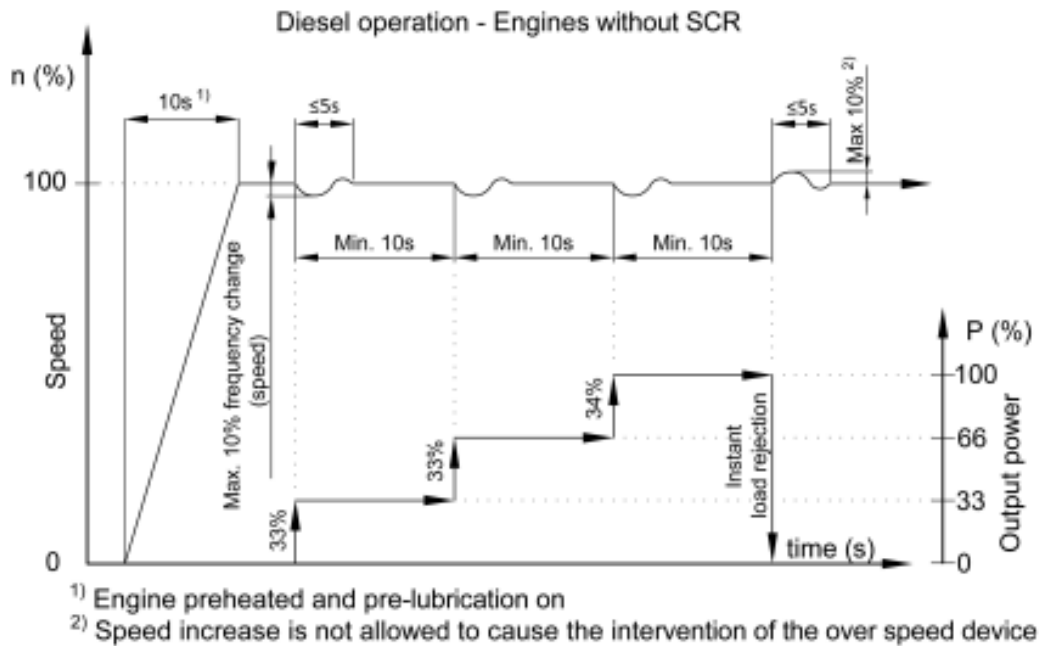

Fig 2-9

ENGINES EQUIPPED WITH SCR (fuel sulphur content $\geq 0.1\%$)**Instant Load Application**

- Maximum load step according to figure below (0 – 25 – 50 – 75 – 100 %)
- Maximum transient speed decrease of 10 % of rated speed
- Steady-state frequency band $\pm 1.0\%$
- Steady-state recovery time ≤ 5 sec.
- Time between load steps ≥ 5 sec., however the max. load limit specified in the graph below should not be exceeded

Engine unloading

- Instant load rejection 100 % - 0 %
- Maximum transient speed increase of 10 % of rated speed
- Steady-state frequency band $\pm 1.0\%$
- Steady-state recovery time ≤ 5 sec.

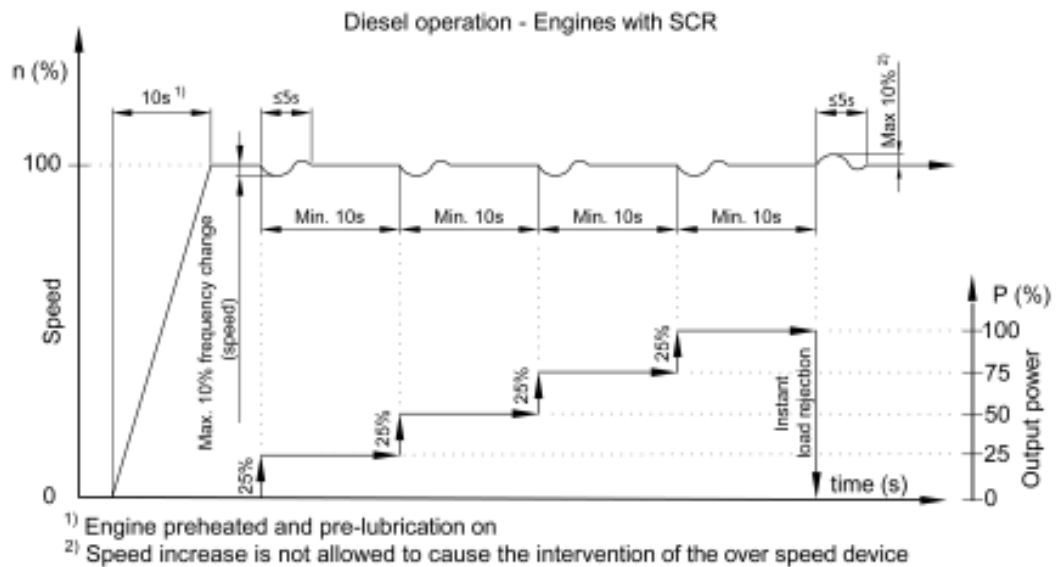
**Fig 2-10**

2.3.2.2 Start-up time

A diesel generator typically reaches nominal speed in about 20...25 seconds after the start signal. The acceleration is limited by the speed control to minimise smoke during start-up.

2.4 Low load operation

Operation below 44 kW/cyl ¹⁾ load on HFO or below 22 kW/cyl ²⁾ load on MDF

- Maximum 100 hours continuous operation. At intervals of 100 operating hours the engine must be loaded to minimum 70 % of the rated output for one hour before continuing with low-load operation or shutting down

Operation at or above 44 kW/cyl ¹⁾ load on HFO or at or above 22 kW/cyl ²⁾ load on MDF

- No restrictions

¹⁾ 20 % from 220 kW/cyl

²⁾ 10 % from 220 kW/cyl

NOTE



Operating restrictions on SCR applications in low load operation to be observed. Please refer to Performance Manual for details.

2.5 Low air temperature

Depending on the setup down to -45°C.

For further guidelines, see chapter *Combustion air system design*.

This page intentionally left blank

3. Technical Data

3.1 Introduction

This chapter contains technical data of the engine (heat balance, flows, pressures etc.) for design of auxiliary systems. Further design criteria for external equipment and system layouts are presented in the respective chapter.

3.1.1 Engine driven pumps

The fuel consumption stated in the technical data tables is with engine driven pumps. The fuel consumption of engine driven pump is given below, correction in g/kWh.

Table 3-1 Constant speed engines

Engine driven pump	Engine load [%] - 900 or 1000 / 1200 rpm			
	100	85	75	50
Lube Oil	2.4 / 2.2	2.8 / 2.5	3.1 / 2.9	4.9 / 4.5
LT Water	0.6 / 0.5	0.7 / 0.6	0.8 / 0.7	1.1 / 1.0
HT Water	0.5 / 0.5	0.6 / 0.6	0.7 / 0.6	1.0 / 1.0
Fuel feed pump	0.1 / 0.1	0.1 / 0.1	0.1 / 0.1	0.2 / 0.1

Table 3-2 Variable speed engines

Engine driven pump	Engine load [%] - 1000 / 1200 rpm			
	100	85	75	50
Lube Oil	3.4 / 3.1	3.6 / 3.3	4.0 / 3.7	5.2 / 5.0
LT Water	0.6 / 0.6	0.6 / 0.5	0.6 / 0.5	0.6 / 0.5
HT Water	0.5 / 0.5	0.5 / 0.5	0.5 / 0.5	0.5 / 0.5
Fuel feed pump	0.1 / 0.1	0.1 / 0.1	0.1 / 0.1	0.1 / 0.1

3.2 Wärtsilä 4L20

3.2.1 IMO Tier 2

Wärtsilä 4L20		AE/DE	AE/DE	ME	ME
Cylinder output	kW	185	200	200	200
Engine speed	RPM	900	1000	1000	1000
Speed mode		Constant	Constant	Variable	Constant
Engine output	kW	740	800	800	800
Mean effective pressure	MPa	2.8	2.73	2.73	2.73
Combustion air system (Note 1)					
Flow at 100% load	kg/s	1.4	1.51	1.51	1.51

Wärtsilä 4L20		AE/DE	AE/DE	ME	ME
Cylinder output	kW	185	200	200	200
Engine speed	RPM	900	1000	1000	1000
Speed mode		Constant	Constant	Variable	Constant
Temperature at turbocharger intake, max.	°C	45	45	45	45
Temperature after air cooler (TE601)	°C	50...70	50...70	50...70	50...70
Exhaust gas system (Note 2)					
Flow at 100% load	kg/s	1.44	1.56	1.56	1.56
Flow at 85% load	kg/s	1.32	1.44	1.4	1.44
Flow at 75% load	kg/s	1.16	1.28	1.2	1.28
Flow at 50% load	kg/s	0.84	0.92	0.8	0.92
Temperature after turbocharger, 100% load (TE517)	°C	363	356	363	356
Temperature after turbocharger, 85% load (TE517)	°C	328	328	330	328
Temperature after turbocharger, 75% load (TE517)	°C	328	328	340	328
Temperature after turbocharger, 50% load (TE517)	°C	348	348	368	348
Backpressure, max.	kPa	5.0	5.0	5.0	5.0
Calculated pipe diameter for 35 m/s	mm	306	317	319	317
Heat balance (Note 3)					
Jacket water, HT-circuit	kW	160	168	168	168
Charge air, LT-circuit	kW	248	272	272	272
Lubricating oil, LT-circuit	kW	116	124	124	124
Radiation	kW	32	32	32	32
Fuel system (Note 4)					
Pressure before injection pumps (PT101)	kPa	700±50	700±50	700±50	700±50
Pressure before engine driven fuel feed pump, min. (MDF only)	kPa	15	15	15	15
Engine driven pump capacity (MDF only)	m³/h	0.78	0.87	0.87	0.87
Fuel flow to engine (without engine driven pump), approx.	m³/h	0.81	0.88	0.89	0.89
HFO viscosity before engine	cSt	16... 24	16... 24	16... 24	16... 24
Max. HFO temperature before engine (TE101)	°C	140	140	140	140
MDF viscosity, min.	cSt	1.8	1.8	1.8	1.8
Max. MDF temperature before engine (TE101)	°C	45	45	45	45
Fuel consumption at 100% load, HFO	g/kWh	198.2	200.1	201.0	200.6
Fuel consumption at 85% load, HFO	g/kWh	196.2	197.1	197.1	197.6
Fuel consumption at 75% load, HFO	g/kWh	197.0	199.0	196.4	199.4
Fuel consumption at 50% load, HFO	g/kWh	209.4	211.3	201.2	211.8
Fuel consumption at 100% load, MDF	g/kWh	197.2	199.1	200.1	199.6
Fuel consumption at 85% load, MDF	g/kWh	195.3	196.3	196.3	196.8
Fuel consumption at 75% load, MDF	g/kWh	196.3	198.2	195.6	198.7
Fuel consumption at 50% load, MDF	g/kWh	209.0	210.9	200.8	211.3

Wärtsilä 4L20		AE/DE	AE/DE	ME	ME
Cylinder output	kW	185	200	200	200
Engine speed	RPM	900	1000	1000	1000
Speed mode		Constant	Constant	Variable	Constant
Clean leak fuel quantity, MDF at 100% load	kg/h	2.16	2.16	2.16	2.16
Lubricating oil system					
Pressure before bearings, nom. (PT201)	kPa	450	450	450	450
Suction ability main pump, including pipe loss, max.	kPa	20	20	20	20
Priming pressure, nom. (PT201)	kPa	80	80	80	80
Suction ability priming pump, including pipe loss, max.	kPa	20	20	20	20
Temperature before bearings, nom. (TE201)	°C	66	66	66	66
Temperature after engine, approx.	°C	78	78	78	78
Pump capacity (main), engine driven	m³/h	24	27	34	27
Priming pump capacity, 50Hz/60Hz	m³/h	8.6 / 10.5	8.6 / 10.5	8.6 / 10.5	8.6 / 10.5
Oil volume, wet sump	m³	0.27	0.27	0.27	0.27
Oil volume in separate system oil tank	m³	1.0	1.1	1.1	1.1
Filter fineness, nom.	mi-crons	25	25	25	25
Oil consumption at 100% load, max.	g/kWh	0.5	0.5	0.5	0.5
Crankcase ventilation flow rate at 100% load	l/min	520	520	520	520
Crankcase ventilation backpressure, max.	kPa	0.3	0.3	0.3	0.3
Oil volume in speed governor	liters	1.4...2.2	1.4...2.2	1.4...2.2	1.4...2.2
Cooling water system					
High temperature cooling water system					
Pressure at engine, after pump, nom. (PT401)	kPa	200 + static	200 + static	200 + static	200 + static
Pressure at engine, after pump, max. (PT401)	kPa	500	500	350	500
Temperature before cylinder, approx. (TE401)	°C	83	83	83	83
Temperature after engine, nom.	°C	91	91	91	91
Capacity of engine driven pump, nom.	m³/h	20	20	20	20
Pressure drop over engine, total	kPa	90	90	90	90
Pressure drop in external system, max.	kPa	120	120	120	120
Water volume in engine	m³	0.09	0.09	0.09	0.09
Pressure from expansion tank	kPa	70...150	70...150	70...150	70...150
Low temperature cooling water system					
Pressure at engine, after pump, nom. (PT451)	kPa	200 + static	200 + static	200 + static	200 + static
Pressure at engine, after pump, max. (PT451)	kPa	500	500	350	500
Temperature before engine, min...max	°C	25...38	25...38	25...38	25...38
Capacity of engine driven pump, nom.	m³/h	23	24	24	24
Pressure drop over charge air cooler	kPa	30	30	30	30
Pressure drop over oil cooler	kPa	30	30	30	30

Wärtsilä 4L20		AE/DE	AE/DE	ME	ME
Cylinder output	kW	185	200	200	200
Engine speed	RPM	900	1000	1000	1000
Speed mode		Constant	Constant	Variable	Constant
Pressure drop in external system, max.	kPa	120	120	120	120
Pressure from expansion tank	kPa	70...150	70...150	70...150	70...150
Starting air system					
Pressure, nom.	kPa	3000	3000	3000	3000
Pressure, max.	kPa	3000	3000	3000	3000
Low pressure limit in air vessels	kPa	1800	1800	1800	1800
Starting air consumption, start (successful)	Nm ³	1.2	1.2	1.2	1.2

Notes:

- Note 1 At ISO 15550 conditions (ambient air temperature 25°C, LT-water 25°C) and 100% load. Flow tolerance 5%.
- Note 2 At ISO 15550 conditions (ambient air temperature 25°C, LT-water 25°C). Flow tolerance 5% and temperature tolerance 15°C.
Also it's possible to have higher than "max" backpressure shown above, please contact Wärtsilä for additional information.
- Note 3 At ISO 15550 conditions (ambient air temperature 25°C, LT-water 25°C) and 100% load. Tolerance for cooling water heat 10%, tolerance for radiation heat 30%. Fouling factors and a margin to be taken into account when dimensioning heat exchangers.
- Note 4 At ambient conditions according to ISO 15550. Lower calorific value 42 700 kJ/kg. With engine driven pumps (two cooling water + one lubricating oil pump). Tolerance 5%.

ME = Engine driving propeller, variable speed

AE = Auxiliary engine driving generator

DE = Diesel-Electric engine driving generator

Subject to revision without notice.

3.2.2 SCR Ready

Wärtsilä 4L20		AE/DE	AE/DE	ME	ME
Cylinder output	kW	185	200	200	200
Engine speed	RPM	900	1000	1000	1000
Speed mode		Constant	Constant	Variable	Constant
Engine output	kW	740	800	800	800
Mean effective pressure	MPa	2.8	2.73	2.73	2.73
Combustion air system (Note 1)					
Flow at 100% load	kg/s	1.4	1.51	1.51	1.51
Temperature at turbocharger intake, max.	°C	45	45	45	45
Temperature after air cooler (TE601)	°C	50...70	50...70	50...70	50...70
Exhaust gas system (Note 2)					
Flow at 100% load	kg/s	1.44	1.56	1.56	1.56
Flow at 85% load	kg/s	1.24	1.4	1.36	1.4
Flow at 75% load	kg/s	1.08	1.24	1.2	1.24
Flow at 50% load	kg/s	0.8	0.8	0.8	0.8
Temperature after turbocharger, 100% load (TE517)	°C	363	358	363	358
Temperature after turbocharger, 85% load (TE517)	°C	340	340	340	340
Temperature after turbocharger, 75% load (TE517)	°C	340	340	340	340
Temperature after turbocharger, 50% load (TE517)	°C	348	348	368	348
Backpressure, max.	kPa	5.0	5.0	5.0	5.0
Calculated pipe diameter for 35 m/s	mm	306	318	319	318
Heat balance (Note 3)					
Jacket water, HT-circuit	kW	160	168	168	168
Charge air, LT-circuit	kW	248	272	272	272
Lubricating oil, LT-circuit	kW	112	124	124	124
Radiation	kW	32	32	32	32
Fuel system (Note 4)					
Pressure before injection pumps (PT101)	kPa	700±50	700±50	700±50	700±50
Pressure before engine driven fuel feed pump, min (MDF only)	kPa	15	15	15	15
Engine driven pump capacity (MDF only)	m³/h	0.78	0.87	0.87	0.87
Fuel flow to engine (without engine driven pump), approx.	m³/h	0.81	0.89	0.89	0.89
HFO viscosity before engine	cSt	16... 24	16... 24	16... 24	16... 24
Max. HFO temperature before engine (TE101)	°C	140	140	140	140
MDF viscosity, min.	cSt	1.8	1.8	1.8	1.8
Max. MDF temperature before engine (TE101)	°C	45	45	45	45
Fuel consumption at 100% load, HFO	g/kWh	198.7	200.4	201.0	200.6
Fuel consumption at 85% load, HFO	g/kWh	198.0	199.0	198.4	199.0

Wärtsilä 4L20		AE/DE	AE/DE	ME	ME
Cylinder output	kW	185	200	200	200
Engine speed	RPM	900	1000	1000	1000
Speed mode		Constant	Constant	Variable	Constant
Fuel consumption at 75% load, HFO	g/kWh	198.4	200.5	197.5	200.5
Fuel consumption at 50% load, HFO	g/kWh	209.4	211.3	201.2	211.8
Fuel consumption at 100% load, MDF	g/kWh	197.7	199.4	200.1	199.6
Fuel consumption at 85% load, MDF	g/kWh	197.1	198.1	197.5	198.1
Fuel consumption at 75% load, MDF	g/kWh	197.6	199.7	196.8	199.7
Fuel consumption at 50% load, MDF	g/kWh	209.0	210.9	200.8	211.3
Clean leak fuel quantity, MDF at 100% load	kg/h	2.16	2.16	2.16	2.16
Lubricating oil system					
Pressure before bearings, nom. (PT201)	kPa	450	450	450	450
Suction ability main pump, including pipe loss, max.	kPa	20	20	20	20
Priming pressure, nom. (PT201)	kPa	80	80	80	80
Suction ability priming pump, including pipe loss, max.	kPa	20	20	20	20
Temperature before bearings, nom. (TE201)	°C	66	66	66	66
Temperature after engine, approx.	°C	78	78	78	78
Pump capacity (main), engine driven	m³/h	24	27	34	27
Priming pump capacity, 50Hz/60Hz	m³/h	8.6 / 10.5	8.6 / 10.5	8.6 / 10.5	8.6 / 10.5
Oil volume, wet sump	m³	0.27	0.27	0.27	0.27
Oil volume in separate system oil tank	m³	1.0	1.1	1.1	1.1
Filter fineness, nom.	microns	25	25	25	25
Oil consumption at 100% load, max.	g/kWh	0.5	0.5	0.5	0.5
Crankcase ventilation flow rate at 100% load	l/min	520	520	520	520
Crankcase ventilation backpressure, max.	kPa	0.3	0.3	0.3	0.3
Oil volume in speed governor	liters	1.4...2.2	1.4...2.2	1.4...2.2	1.4...2.2
Cooling water system					
High temperature cooling water system					
Pressure at engine, after pump, nom. (PT401)	kPa	200 + static	200 + static	200 + static	200 + static
Pressure at engine, after pump, max. (PT401)	kPa	500	500	350	500
Temperature before cylinder, approx. (TE401)	°C	83	83	83	83
Temperature after engine, nom.	°C	91	91	91	91
Capacity of engine driven pump, nom.	m³/h	20	20	20	20
Pressure drop over engine, total	kPa	90	90	90	90
Pressure drop in external system, max.	kPa	120	120	120	120
Water volume in engine	m³	0.09	0.09	0.09	0.09
Pressure from expansion tank	kPa	70...150	70...150	70...150	70...150
Low temperature cooling water system					

Wärtsilä 4L20		AE/DE	AE/DE	ME	ME
Cylinder output	kW	185	200	200	200
Engine speed	RPM	900	1000	1000	1000
Speed mode		Constant	Constant	Variable	Constant
Pressure at engine, after pump, nom. (PT451)	kPa	200 + static	200 + static	200 + static	200 + static
Pressure at engine, after pump, max. (PT451)	kPa	500	500	350	500
Temperature before engine, min...max	°C	25...38	25...38	25...38	25...38
Capacity of engine driven pump, nom.	m ³ /h	23	24	24	24
Pressure drop over charge air cooler	kPa	30	30	30	30
Pressure drop over oil cooler	kPa	30	30	30	30
Pressure drop in external system, max.	kPa	120	120	120	120
Pressure from expansion tank	kPa	70...150	70...150	70...150	70...150
Starting air system					
Pressure, nom.	kPa	3000	3000	3000	3000
Pressure, max.	kPa	3000	3000	3000	3000
Low pressure limit in air vessels	kPa	1800	1800	1800	1800
Starting air consumption, start (successful)	Nm ³	1.2	1.2	1.2	1.2

Notes:

- Note 1 At ISO 15550 conditions (ambient air temperature 25°C, LT-water 25°C) and 100% load. Flow tolerance 5%.
- Note 2 At ISO 15550 conditions (ambient air temperature 25°C, LT-water 25°C). Flow tolerance 5% and temperature tolerance 15°C.
Also it's possible to have higher than "max" backpressure shown above, please contact Wärtsilä for additional information.
- Note 3 At ISO 15550 conditions (ambient air temperature 25°C, LT-water 25°C) and 100% load. Tolerance for cooling water heat 10%, tolerance for radiation heat 30%. Fouling factors and a margin to be taken into account when dimensioning heat exchangers.
- Note 4 At ambient conditions according to ISO 15550. Lower calorific value 42 700 kJ/kg. With engine driven pumps (two cooling water + one lubricating oil pump). Tolerance 5%.

ME = Engine driving propeller, variable speed

AE = Auxiliary engine driving generator

DE = Diesel-Electric engine driving generator

Subject to revision without notice.

3.3 Wärtsilä 6L20

3.3.1 IMO Tier 2

Wärtsilä 6L20		AE/DE	AE/DE	AE/DE LFO Op- timized	AE/DE HFO Op- timized	ME	ME LFO Op- timized	ME HFO Op- timized	ME	ME LFO Op- timized	ME HFO Op- timized
Cylinder output	kW	185	200	220	220	200	220	220	200	220	220
Engine speed	RPM	900	1000	1200	1200	1000	1200	1200	1000	1200	1200
Speed mode		Constant	Constant	Constant	Constant	Variable	Variable	Variable	Constant	Constant	Constant
Engine output	kW	1110	1200	1320	1320	1200	1320	1320	1200	1320	1320
Mean effective pressure	MPa	2.8	2.73	2.5	2.5	2.73	2.5	2.5	2.73	2.5	2.5
Combustion air system (Note 1)											
Flow at 100% load	kg/s	2.1	2.27	2.69	2.69	2.27	2.8	2.8	2.27	2.68	2.68
Temperature at turbocharger intake, max.	°C	45	45	45	45	45	45	45	45	45	45
Temperature after air cooler (TE601)	°C	50...70	50...70	50...70	50...70	50...70	50...70	50...70	50...70	50...70	50...70
Exhaust gas system (Note 2)											
Flow at 100% load	kg/s	2.16	2.34	2.76	2.76	2.34	2.88	2.88	2.34	2.76	2.76
Flow at 85% load	kg/s	1.98	2.16	2.4	2.4	2.1	2.4	2.4	2.16	2.4	2.4
Flow at 75% load	kg/s	1.74	1.92	2.16	2.16	1.8	2.04	2.04	1.92	2.16	2.16
Flow at 50% load	kg/s	1.26	1.38	1.5	1.5	1.2	1.38	1.38	1.38	1.5	1.5
Temperature after turbocharger, 100% load (TE517)	°C	363	356	316	316	363	319	319	356	316	316
Temperature after turbocharger, 85% load (TE517)	°C	328	328	304	304	330	313	313	328	304	304
Temperature after turbocharger, 75% load (TE517)	°C	328	328	307	307	340	329	329	328	307	307
Temperature after turbocharger, 50% load (TE517)	°C	348	348	337	337	368	333	333	348	337	337
Backpressure, max.	kPa	5.0	5.0	5.0	5.0	5.0	5.0	5.0	5.0	5.0	5.0
Calculated pipe diameter for 35 m/s	mm	375	388	408	408	391	418	418	388	408	408
Heat balance (Note 3)											
Jacket water, HT-circuit	kW	240	252	294	294	252	294	294	252	294	294
Charge air, LT-circuit	kW	372	408	468	468	408	528	528	408	468	468
Lubricating oil, LT-circuit	kW	174	186	156	156	186	162	162	186	156	156
Radiation	kW	48	48	47	47	48	47	47	48	47	47
Fuel system (Note 4)											
Pressure before injection pumps (PT101)	kPa	700±50	700±50	700±50	700±50	700±50	700±50	700±50	700±50	700±50	700±50
Pressure before engine driven fuel feed pump, min. (MDF only)	kPa	15	15	15	15	15	15	15	15	15	15
Engine driven pump capacity (MDF only)	m³/h	1.34	1.49	1.5	n/a	1.49	1.5	n/a	1.49	1.5	n/a
Fuel flow to engine (without engine driven pump), approx.	m³/h	1.19	1.3	n/a	1.44	1.3	n/a	1.47	1.3	n/a	1.47
HFO viscosity before engine	cSt	16... 24	16... 24	n/a	16... 24	16... 24	n/a	16... 24	16... 24	n/a	16... 24

Wärtsilä 6L20		AE/DE	AE/DE	AE/DE LFO Op- timized	AE/DE HFO Op- timized	ME	ME LFO Op- timized	ME HFO Op- timized	ME	ME LFO Op- timized	ME HFO Op- timized
Cylinder output	kW	185	200	220	220	200	220	220	200	220	220
Engine speed	RPM	900	1000	1200	1200	1000	1200	1200	1000	1200	1200
Speed mode		Constant	Constant	Constant	Constant	Variable	Variable	Variable	Constant	Constant	Constant
Max. HFO temperature before engine (TE101)	°C	140	140	n/a	140	140	n/a	140	140	n/a	140
MDF viscosity, min.	cSt	1.8	1.8	1.8	1.8	1.8	1.8	1.8	1.8	1.8	1.8
Max. MDF temperature before engine (TE101)	°C	45	45	45	45	45	45	45	45	45	45
Fuel consumption at 100% load, HFO	g/kWh	193.4	195.8	n/a	197.7	196.3	n/a	201.6	196.3	n/a	201.6
Fuel consumption at 85% load, HFO	g/kWh	190.8	192.2	n/a	195.3	190.9	n/a	197.0	192.7	n/a	198.3
Fuel consumption at 75% load, HFO	g/kWh	190.4	192.3	n/a	196.2	190.2	n/a	194.4	192.8	n/a	198.9
Fuel consumption at 50% load, HFO	g/kWh	196.9	199.0	n/a	205.0	194.5	n/a	195.0	199.4	n/a	206.7
Fuel consumption at 100% load, MDF	g/kWh	192.5	194.9	195.7	197.6	195.3	199.6	202.4	195.3	199.6	201.5
Fuel consumption at 85% load, MDF	g/kWh	189.9	191.3	194.5	195.9	190.0	194.8	197.0	191.8	197.0	198.4
Fuel consumption at 75% load, MDF	g/kWh	189.6	191.5	195.4	196.6	189.4	192.5	194.4	192.0	197.7	198.9
Fuel consumption at 50% load, MDF	g/kWh	196.4	198.5	204.6	205.0	194.0	192.5	193.4	199.0	205.9	206.4
Clean leak fuel quantity, MDF at 100% load	kg/h	3.24	3.24	3.24	3.24	3.24	3.24	3.24	3.24	3.24	3.24
Lubricating oil system											
Pressure before bearings, nom. (PT201)	kPa	450	450	450	450	450	450	450	450	450	450
Suction ability main pump, including pipe loss, max.	kPa	20	20	20	20	20	20	20	20	20	20
Priming pressure, nom. (PT201)	kPa	80	80	80	80	80	80	80	80	80	80
Suction ability priming pump, including pipe loss, max.	kPa	20	20	20	20	20	20	20	20	20	20
Temperature before bearings, nom. (TE201)	°C	66	66	66	66	66	66	66	66	66	66
Temperature after engine, approx.	°C	78	78	78	78	78	78	78	78	78	78
Pump capacity (main), engine driven	m³/h	31	34	34	34	48	48	48	34	34	34
Priming pump capacity, 50Hz/60Hz	m³/h	8.6 / 10.5	8.6 / 10.5	8.6 / 10.5	8.6 / 10.5	8.6 / 10.5	8.6 / 10.5	8.6 / 10.5	8.6 / 10.5	8.6 / 10.5	8.6 / 10.5
Oil volume, wet sump	m³	0.38	0.38	0.38	0.38	0.5	0.5	0.5	0.5	0.5	0.5
Oil volume in separate system oil tank	m³	1.5	1.6	1.8	1.8	1.6	1.8	1.8	1.6	1.8	1.8
Filter fineness, nom.	microns	25	25	25	25	25	25	25	25	25	25
Oil consumption at 100% load, max.	g/kWh	0.5	0.5	0.35	0.35	0.5	0.35	0.35	0.5	0.35	0.35
Crankcase ventilation flow rate at 100% load	l/min	780	780	780	780	780	780	780	780	780	780
Crankcase ventilation backpressure, max.	kPa	0.3	0.3	0.3	0.3	0.3	0.3	0.3	0.3	0.3	0.3
Oil volume in speed governor	liters	1.4...2.2	1.4...2.2	1.4...2.2	1.4...2.2	1.4...2.2	1.4...2.2	1.4...2.2	1.4...2.2	1.4...2.2	1.4...2.2
Cooling water system											
High temperature cooling water system											
Pressure at engine, after pump, nom. (PT401)	kPa	200 + static	200 + static	200 + static	200 + static	200 + static	200 + static	200 + static	200 + static	200 + static	200 + static
Pressure at engine, after pump, max. (PT401)	kPa	500	500	500	500	350	350	350	500	500	500

Wärtsilä 6L20		AE/DE	AE/DE	AE/DE LFO Op- timized	AE/DE HFO Op- timized	ME	ME LFO Op- timized	ME HFO Op- timized	ME	ME LFO Op- timized	ME HFO Op- timized
Cylinder output	kW	185	200	220	220	200	220	220	200	220	220
Engine speed	RPM	900	1000	1200	1200	1000	1200	1200	1000	1200	1200
Speed mode		Constant	Constant	Constant	Constant	Variable	Variable	Variable	Constant	Constant	Constant
Temperature before cylinder, approx. (TE401)	°C	83	83	83	83	83	83	83	83	83	83
Temperature after engine, nom.	°C	91	91	91	91	91	91	91	91	91	91
Capacity of engine driven pump, nom.	m ³ /h	29	30	30	30	30	30	30	30	30	30
Pressure drop over engine, total	kPa	90	90	90	90	90	90	90	90	90	90
Pressure drop in external system, max.	kPa	120	120	120	120	120	120	120	120	120	120
Water volume in engine	m ³	0.12	0.12	0.12	0.12	0.12	0.12	0.12	0.12	0.12	0.12
Pressure from expansion tank	kPa	70...150	70...150	70...150	70...150	70...150	70...150	70...150	70...150	70...150	70...150
Low temperature cooling water system											
Pressure at engine, after pump, nom. (PT451)	kPa	200 + static	200 + static	200 + static	200 + static	200 + static	200 + static	200 + static	200 + static	200 + static	200 + static
Pressure at engine, after pump, max. (PT451)	kPa	500	500	500	500	350	350	350	500	500	500
Temperature before engine, min...max	°C	25...38	25...38	25...38	25...38	25...38	25...38	25...38	25...38	25...38	25...38
Capacity of engine driven pump, nom.	m ³ /h	34	36	39	39	36	39	39	36	39	39
Pressure drop over charge air cooler	kPa	30	30	30	30	30	30	30	30	30	30
Pressure drop over oil cooler	kPa	30	30	30	30	30	30	30	30	30	30
Pressure drop in external system, max.	kPa	120	120	120	120	120	120	120	120	120	120
Pressure from expansion tank	kPa	70...150	70...150	70...150	70...150	70...150	70...150	70...150	70...150	70...150	70...150
Starting air system											
Pressure, nom.	kPa	3000	3000	3000	3000	3000	3000	3000	3000	3000	3000
Pressure, max.	kPa	3000	3000	3000	3000	3000	3000	3000	3000	3000	3000
Low pressure limit in air vessels	kPa	1800	1800	1800	1800	1800	1800	1800	1800	1800	1800
Starting air consumption, start (successful)	Nm ³	1.2	1.2	1.2	1.2	1.2	1.2	1.2	1.2	1.2	1.2

Notes:

- Note 1 At ISO 15550 conditions (ambient air temperature 25°C, LT-water 25°C) and 100% load. Flow tolerance 5%.
- Note 2 At ISO 15550 conditions (ambient air temperature 25°C, LT-water 25°C). Flow tolerance 5% and temperature tolerance 15°C.
Also it's possible to have higher than "max" backpressure shown above, please contact Wärtsilä for additional information.
- Note 3 At ISO 15550 conditions (ambient air temperature 25°C, LT-water 25°C) and 100% load. Tolerance for cooling water heat 10%, tolerance for radiation heat 30%. Fouling factors and a margin to be taken into account when dimensioning heat exchangers.
- Note 4 At ambient conditions according to ISO 15550. Lower calorific value 42 700 kJ/kg. With engine driven pumps (two cooling water + one lubricating oil pump). Tolerance 5%.

ME = Engine driving propeller, variable speed

AE = Auxiliary engine driving generator

DE = Diesel-Electric engine driving generator

Subject to revision without notice.

3.3.2 SCR Ready

3.3.2.1 900 & 1000 rpm

Wärtsilä 6L20		AE/DE	AE/DE	ME	ME
Cylinder output	kW	185	200	200	200
Engine speed	RPM	900	1000	1000	1000
Speed mode		Constant	Constant	Variable	Constant
Engine output	kW	1110	1200	1200	1200
Mean effective pressure	MPa	2.8	2.73	2.73	2.73
Combustion air system (Note 1)					
Flow at 100% load	kg/s	2.1	2.27	2.27	2.27
Temperature at turbocharger intake, max.	°C	45	45	45	45
Temperature after air cooler (TE601)	°C	50...70	50...70	50...70	50...70
Exhaust gas system (Note 2)					
Flow at 100% load	kg/s	2.16	2.34	2.34	2.34
Flow at 85% load	kg/s	1.86	2.1	2.04	2.1
Flow at 75% load	kg/s	1.62	1.86	1.8	1.86
Flow at 50% load	kg/s	1.2	1.2	1.2	1.2
Temperature after turbocharger, 100% load (TE517)	°C	363	358	363	358
Temperature after turbocharger, 85% load (TE517)	°C	340	340	340	340
Temperature after turbocharger, 75% load (TE517)	°C	340	340	340	340
Temperature after turbocharger, 50% load (TE517)	°C	348	348	368	348
Backpressure, max.	kPa	5.0	5.0	5.0	5.0
Calculated pipe diameter for 35 m/s	mm	375	389	391	389
Heat balance (Note 3)					
Jacket water, HT-circuit	kW	240	252	252	252
Charge air, LT-circuit	kW	372	408	408	408
Lubricating oil, LT-circuit	kW	168	186	186	186
Radiation	kW	48	48	48	48
Fuel system (Note 4)					
Pressure before injection pumps (PT101)	kPa	700±50	700±50	700±50	700±50
Pressure before engine driven fuel feed pump, min. (MDF only)	kPa	15	15	15	15
Engine driven pump capacity (MDF only)	m³/h	1.34	1.49	1.49	1.49
Fuel flow to engine (without engine driven pump), approx.	m³/h	1.2	1.3	1.3	1.3
HFO viscosity before engine	cSt	16... 24	16... 24	16... 24	16... 24
Max. HFO temperature before engine (TE101)	°C	140	140	140	140

Wärtsilä 6L20		AE/DE	AE/DE	ME	ME
Cylinder output	kW	185	200	200	200
Engine speed	RPM	900	1000	1000	1000
Speed mode		Constant	Constant	Variable	Constant
MDF viscosity, min.	cSt	1.8	1.8	1.8	1.8
Max. MDF temperature before engine (TE101)	°C	45	45	45	45
Fuel consumption at 100% load, HFO	g/kWh	195.0	196.3	196.3	196.3
Fuel consumption at 85% load, HFO	g/kWh	193.8	195.2	192.9	195.2
Fuel consumption at 75% load, HFO	g/kWh	192.6	194.9	192.1	194.9
Fuel consumption at 50% load, HFO	g/kWh	196.9	199.0	194.5	199.4
Fuel consumption at 100% load, MDF	g/kWh	194.1	195.3	195.3	195.3
Fuel consumption at 85% load, MDF	g/kWh	193.0	194.4	192.0	194.4
Fuel consumption at 75% load, MDF	g/kWh	191.8	194.1	191.3	194.1
Fuel consumption at 50% load, MDF	g/kWh	196.4	198.5	194.0	199.0
Clean leak fuel quantity, MDF at 100% load	kg/h	3.24	3.24	3.24	3.24
Lubricating oil system					
Pressure before bearings, nom. (PT201)	kPa	450	450	450	450
Suction ability main pump, including pipe loss, max.	kPa	20	20	20	20
Priming pressure, nom. (PT201)	kPa	80	80	80	80
Suction ability priming pump, including pipe loss, max.	kPa	20	20	20	20
Temperature before bearings, nom. (TE201)	°C	66	66	66	66
Temperature after engine, approx.	°C	78	78	78	78
Pump capacity (main), engine driven	m³/h	31	34	48	34
Priming pump capacity, 50Hz/60Hz	m³/h	8.6 / 10.5	8.6 / 10.5	8.6 / 10.5	8.6 / 10.5
Oil volume, wet sump	m³	0.38	0.38	0.5	0.5
Oil volume in separate system oil tank	m³	1.5	1.6	1.6	1.6
Filter fineness, nom.	mi-crons	25	25	25	25
Oil consumption at 100% load, max.	g/kWh	0.5	0.5	0.5	0.5
Crankcase ventilation flow rate at 100% load	l/min	780	780	780	780
Crankcase ventilation backpressure, max.	kPa	0.3	0.3	0.3	0.3
Oil volume in speed governor	liters	1.4...2.2	1.4...2.2	1.4...2.2	1.4...2.2
Cooling water system					
High temperature cooling water system					
Pressure at engine, after pump, nom. (PT401)	kPa	200 + static	200 + static	200 + static	200 + static
Pressure at engine, after pump, max. (PT401)	kPa	500	500	350	500
Temperature before cylinder, approx. (TE401)	°C	83	83	83	83
Temperature after engine, nom.	°C	91	91	91	91
Capacity of engine driven pump, nom.	m³/h	29	30	30	30

Wärtsilä 6L20		AE/DE	AE/DE	ME	ME
Cylinder output	kW	185	200	200	200
Engine speed	RPM	900	1000	1000	1000
Speed mode		Constant	Constant	Variable	Constant
Pressure drop over engine, total	kPa	90	90	90	90
Pressure drop in external system, max.	kPa	120	120	120	120
Water volume in engine	m ³	0.12	0.12	0.12	0.12
Pressure from expansion tank	kPa	70...150	70...150	70...150	70...150
Low temperature cooling water system					
Pressure at engine, after pump, nom. (PT451)	kPa	200 + static	200 + static	200 + static	200 + static
Pressure at engine, after pump, max. (PT451)	kPa	500	500	350	500
Temperature before engine, min...max	°C	25...38	25...38	25...38	25...38
Capacity of engine driven pump, nom.	m ³ /h	34	36	36	36
Pressure drop over charge air cooler	kPa	30	30	30	30
Pressure drop over oil cooler	kPa	30	30	30	30
Pressure drop in external system, max.	kPa	120	120	120	120
Pressure from expansion tank	kPa	70...150	70...150	70...150	70...150
Starting air system					
Pressure, nom.	kPa	3000	3000	3000	3000
Pressure, max.	kPa	3000	3000	3000	3000
Low pressure limit in air vessels	kPa	1800	1800	1800	1800
Starting air consumption, start (successful)	Nm ³	1.2	1.2	1.2	1.2

Notes:

- Note 1 At ISO 15550 conditions (ambient air temperature 25°C, LT-water 25°C) and 100% load. Flow tolerance 5%.
- Note 2 At ISO 15550 conditions (ambient air temperature 25°C, LT-water 25°C). Flow tolerance 5% and temperature tolerance 15°C.
Also it's possible to have higher than "max" backpressure shown above, please contact Wärtsilä for additional information.
- Note 3 At ISO 15550 conditions (ambient air temperature 25°C, LT-water 25°C) and 100% load. Tolerance for cooling water heat 10%, tolerance for radiation heat 30%. Fouling factors and a margin to be taken into account when dimensioning heat exchangers.
- Note 4 At ambient conditions according to ISO 15550. Lower calorific value 42 700 kJ/kg. With engine driven pumps (two cooling water + one lubricating oil pump). Tolerance 5%.

ME = Engine driving propeller, variable speed

AE = Auxiliary engine driving generator

DE = Diesel-Electric engine driving generator

Subject to revision without notice.

3.3.2.2 1200 rpm fuel sulphur content $\leq 0,5\%$

Wärtsilä 6L20		AE/DE LFO Op- timized	ME LFO Op- timized	ME LFO Op- timized	AE/DE HFO Op- timized	ME HFO Op- timized	ME HFO Op- timized
Cylinder output	kW	220	220	220	220	220	220
Engine speed	RPM	1200	1200	1200	1200	1200	1200
Speed mode		Constant	Variable	Constant	Constant	Variable	Constant
Engine output	kW	1320	1320	1320	1320	1320	1320
Mean effective pressure	MPa	2.5	2.5	2.5	2.5	2.5	2.5
Combustion air system (Note 1)							
Flow at 100% load	kg/s	2.69	2.8	2.68	2.69	2.8	2.68
Temperature at turbocharger intake, max.	°C	45	45	45	45	45	45
Temperature after air cooler (TE601)	°C	50...70	50...70	50...70	50...70	50...70	50...70
Exhaust gas system (Note 2)							
Flow at 100% load	kg/s	2.76	2.88	2.76	2.76	2.88	2.76
Flow at 85% load	kg/s	2.34	2.34	2.34	2.34	2.34	2.34
Flow at 75% load	kg/s	2.1	2.04	2.1	2.1	2.04	2.1
Flow at 50% load	kg/s	1.5	1.38	1.5	1.5	1.38	1.5
Temperature after turbocharger, 100% load (TE517)	°C	320	320	320	320	320	320
Temperature after turbocharger, 85% load (TE517)	°C	320	320	320	320	320	320
Temperature after turbocharger, 75% load (TE517)	°C	320	329	320	320	329	320
Temperature after turbocharger, 50% load (TE517)	°C	337	333	337	337	333	337
Backpressure, max.	kPa	5.0	5.0	5.0	5.0	5.0	5.0
Calculated pipe diameter for 35 m/s	mm	410	418	410	410	418	410
Heat balance (Note 3)							
Jacket water, HT-circuit	kW	300	294	300	300	294	300
Charge air, LT-circuit	kW	468	528	468	468	528	468
Lubricating oil, LT-circuit	kW	156	162	156	156	162	156
Radiation	kW	47	47	47	47	47	47
Fuel system (Note 4)							
Pressure before injection pumps (PT101)	kPa	700±50	700±50	700±50	700±50	700±50	700±50
Pressure before engine driven fuel feed pump, min. (MDF only)	kPa	15	15	15	15	15	15
Engine driven pump capacity (MDF only)	m³/h	1.5	1.5	1.5	n/a	n/a	n/a
Fuel flow to engine (without engine driven pump), approx.	m³/h	n/a	n/a	n/a	1.45	1.47	1.47
HFO viscosity before engine	cSt	n/a	n/a	n/a	16... 24	16... 24	16... 24
Max. HFO temperature before engine (TE101)	°C	n/a	n/a	n/a	140	140	140
MDF viscosity, min.	cSt	1.8	1.8	1.8	1.8	1.8	1.8

Wärtsilä 6L20		AE/DE LFO Optimized	ME LFO Optimized	ME LFO Optimized	AE/DE HFO Optimized	ME HFO Optimized	ME HFO Optimized
Cylinder output	kW	220	220	220	220	220	220
Engine speed	RPM	1200	1200	1200	1200	1200	1200
Speed mode		Constant	Variable	Constant	Constant	Variable	Constant
Max. MDF temperature before engine (TE101)	°C	45	45	45	45	45	45
Fuel consumption at 100% load, HFO	g/kWh	n/a	n/a	n/a	198.1	201.6	201.6
Fuel consumption at 85% load, HFO	g/kWh	n/a	n/a	n/a	197.0	197.1	200.0
Fuel consumption at 75% load, HFO	g/kWh	n/a	n/a	n/a	197.9	194.4	200.6
Fuel consumption at 50% load, HFO	g/kWh	n/a	n/a	n/a	205.0	195.0	206.7
Fuel consumption at 100% load, MDF	g/kWh	196.1	199.6	199.6	197.9	202.4	201.8
Fuel consumption at 85% load, MDF	g/kWh	196.2	195.0	198.8	197.7	197.1	200.2
Fuel consumption at 75% load, MDF	g/kWh	197.1	192.5	199.4	198.3	194.4	200.6
Fuel consumption at 50% load, MDF	g/kWh	204.6	192.5	205.9	205.0	193.4	206.4
Clean leak fuel quantity, MDF at 100% load	kg/h	3.24	3.24	3.24	3.24	3.24	3.24
Lubricating oil system							
Pressure before bearings, nom. (PT201)	kPa	450	450	450	450	450	450
Suction ability main pump, including pipe loss, max.	kPa	20	20	20	20	20	20
Priming pressure, nom. (PT201)	kPa	80	80	80	80	80	80
Suction ability priming pump, including pipe loss, max.	kPa	20	20	20	20	20	20
Temperature before bearings, nom. (TE201)	°C	66	66	66	66	66	66
Temperature after engine, approx.	°C	78	78	78	78	78	78
Pump capacity (main), engine driven	m³/h	34	48	34	34	48	34
Priming pump capacity, 50Hz/60Hz	m³/h	8.6 / 10.5	8.6 / 10.5	8.6 / 10.5	8.6 / 10.5	8.6 / 10.5	8.6 / 10.5
Oil volume, wet sump	m³	0.38	0.5	0.5	0.38	0.5	0.5
Oil volume in separate system oil tank	m³	1.8	1.8	1.8	1.8	1.8	1.8
Filter fineness, nom.	microns	25	25	25	25	25	25
Oil consumption at 100% load, max.	g/kWh	0.35	0.35	0.35	0.35	0.35	0.35
Crankcase ventilation flow rate at 100% load	l/min	780	780	780	780	780	780
Crankcase ventilation backpressure, max.	kPa	0.3	0.3	0.3	0.3	0.3	0.3
Oil volume in speed governor	liters	1.4...2.2	1.4...2.2	1.4...2.2	1.4...2.2	1.4...2.2	1.4...2.2
Cooling water system							
High temperature cooling water system							
Pressure at engine, after pump, nom. (PT401)	kPa	200 + static	200 + static	200 + static	200 + static	200 + static	200 + static
Pressure at engine, after pump, max. (PT401)	kPa	500	350	500	500	350	500
Temperature before cylinder, approx. (TE401)	°C	83	83	83	83	83	83
Temperature after engine, nom.	°C	91	91	91	91	91	91

Wärtsilä 6L20		AE/DE LFO Op- timized	ME LFO Op- timized	ME LFO Op- timized	AE/DE HFO Op- timized	ME HFO Op- timized	ME HFO Op- timized
Cylinder output	kW	220	220	220	220	220	220
Engine speed	RPM	1200	1200	1200	1200	1200	1200
Speed mode		Constant	Variable	Constant	Constant	Variable	Constant
Capacity of engine driven pump, nom.	m ³ /h	30	30	30	30	30	30
Pressure drop over engine, total	kPa	90	90	90	90	90	90
Pressure drop in external system, max.	kPa	120	120	120	120	120	120
Water volume in engine	m ³	0.12	0.12	0.12	0.12	0.12	0.12
Pressure from expansion tank	kPa	70...150	70...150	70...150	70...150	70...150	70...150
Low temperature cooling water system							
Pressure at engine, after pump, nom. (PT451)	kPa	200 + static	200 + static	200 + static	200 + static	200 + static	200 + static
Pressure at engine, after pump, max. (PT451)	kPa	500	350	500	500	350	500
Temperature before engine, min...max	°C	25...38	25...38	25...38	25...38	25...38	25...38
Capacity of engine driven pump, nom.	m ³ /h	39	39	39	39	39	39
Pressure drop over charge air cooler	kPa	30	30	30	30	30	30
Pressure drop over oil cooler	kPa	30	30	30	30	30	30
Pressure drop in external system, max.	kPa	120	120	120	120	120	120
Pressure from expansion tank	kPa	70...150	70...150	70...150	70...150	70...150	70...150
Starting air system							
Pressure, nom.	kPa	3000	3000	3000	3000	3000	3000
Pressure, max.	kPa	3000	3000	3000	3000	3000	3000
Low pressure limit in air vessels	kPa	1800	1800	1800	1800	1800	1800
Starting air consumption, start (successful)	Nm ³	1.2	1.2	1.2	1.2	1.2	1.2

Notes:

- Note 1 At ISO 15550 conditions (ambient air temperature 25°C, LT-water 25°C) and 100% load. Flow tolerance 5%.
- Note 2 At ISO 15550 conditions (ambient air temperature 25°C, LT-water 25°C). Flow tolerance 5% and temperature tolerance 15°C.
Also it's possible to have higher than "max" backpressure shown above, please contact Wärtsilä for additional information.
- Note 3 At ISO 15550 conditions (ambient air temperature 25°C, LT-water 25°C) and 100% load. Tolerance for cooling water heat 10%, tolerance for radiation heat 30%. Fouling factors and a margin to be taken into account when dimensioning heat exchangers.
- Note 4 At ambient conditions according to ISO 15550. Lower calorific value 42 700 kJ/kg. With engine driven pumps (two cooling water + one lubricating oil pump). Tolerance 5%.

ME = Engine driving propeller, variable speed

AE = Auxiliary engine driving generator

DE = Diesel-Electric engine driving generator

Subject to revision without notice.

3.3.2.3 1200 rpm fuel sulphur content > 0,5%

Wärtsilä 6L20		AE/DE LFO Optimized	ME LFO Optimized	ME LFO Optimized	AE/DE HFO Optimized	ME HFO Optimized	ME HFO Optimized
Cylinder output	kW	220	220	220	220	220	220
Engine speed	RPM	1200	1200	1200	1200	1200	1200
Speed mode		Constant	Variable	Constant	Constant	Variable	Constant
Engine output	kW	1320	1320	1320	1320	1320	1320
Mean effective pressure	MPa	2.5	2.5	2.5	2.5	2.5	2.5
Combustion air system (Note 1)							
Flow at 100% load	kg/s	2.5	2.62	2.5	2.5	2.62	2.5
Temperature at turbocharger intake, max.	°C	45	45	45	45	45	45
Temperature after air cooler (TE601)	°C	50...70	50...70	50...70	50...70	50...70	50...70
Exhaust gas system (Note 2)							
Flow at 100% load	kg/s	2.58	2.7	2.58	2.58	2.7	2.58
Flow at 85% load	kg/s	2.22	2.28	2.22	2.22	2.28	2.22
Flow at 75% load	kg/s	1.98	1.98	1.98	1.98	1.98	1.98
Flow at 50% load	kg/s	1.44	1.38	1.44	1.44	1.38	1.44
Temperature after turbocharger, 100% load (TE517)	°C	340	340	340	340	340	340
Temperature after turbocharger, 85% load (TE517)	°C	340	340	340	340	340	340
Temperature after turbocharger, 75% load (TE517)	°C	340	340	340	340	340	340
Temperature after turbocharger, 50% load (TE517)	°C	340	340	340	340	340	340
Backpressure, max.	kPa	5.0	5.0	5.0	5.0	5.0	5.0
Calculated pipe diameter for 35 m/s	mm	403	412	403	403	412	403
Heat balance (Note 3)							
Jacket water, HT-circuit	kW	324	318	324	324	318	324
Charge air, LT-circuit	kW	468	528	468	468	528	468
Lubricating oil, LT-circuit	kW	162	168	162	162	168	162
Radiation	kW	49	49	49	49	49	49
Fuel system (Note 4)							
Pressure before injection pumps (PT101)	kPa	700±50	700±50	700±50	700±50	700±50	700±50
Pressure before engine driven fuel feed pump, min. (MDF only)	kPa	15	15	15	15	15	15
Engine driven pump capacity (MDF only)	m³/h	1.5	1.5	1.5	n/a	n/a	n/a
Fuel flow to engine (without engine driven pump), approx.	m³/h	n/a	n/a	n/a	1.47	1.49	1.49
HFO viscosity before engine	cSt	n/a	n/a	n/a	16... 24	16... 24	16... 24
Max. HFO temperature before engine (TE101)	°C	n/a	n/a	n/a	140	140	140
MDF viscosity, min.	cSt	1.8	1.8	1.8	1.8	1.8	1.8

Wärtsilä 6L20		AE/DE LFO Op- timized	ME LFO Op- timized	ME LFO Op- timized	AE/DE HFO Op- timized	ME HFO Op- timized	ME HFO Op- timized
Cylinder output	kW	220	220	220	220	220	220
Engine speed	RPM	1200	1200	1200	1200	1200	1200
Speed mode		Constant	Variable	Constant	Constant	Variable	Constant
Max. MDF temperature before engine (TE101)	°C	45	45	45	45	45	45
Fuel consumption at 100% load, HFO	g/kWh	n/a	n/a	n/a	201.0	203.9	203.9
Fuel consumption at 85% load, HFO	g/kWh	n/a	n/a	n/a	199.6	198.6	200.9
Fuel consumption at 75% load, HFO	g/kWh	n/a	n/a	n/a	200.2	196.3	201.3
Fuel consumption at 50% load, HFO	g/kWh	n/a	n/a	n/a	207.3	196.6	208.0
Fuel consumption at 100% load, MDF	g/kWh	199.0	201.9	201.9	201.0	204.7	203.8
Fuel consumption at 85% load, MDF	g/kWh	198.8	196.9	199.5	200.3	199.0	201.0
Fuel consumption at 75% load, MDF	g/kWh	199.4	193.5	200.2	200.7	195.4	201.3
Fuel consumption at 50% load, MDF	g/kWh	206.9	193.0	207.2	207.2	194.0	207.7
Clean leak fuel quantity, MDF at 100% load	kg/h	3.24	3.24	3.24	3.24	3.24	3.24
Lubricating oil system							
Pressure before bearings, nom. (PT201)	kPa	450	450	450	450	450	450
Suction ability main pump, including pipe loss, max.	kPa	20	20	20	20	20	20
Priming pressure, nom. (PT201)	kPa	80	80	80	80	80	80
Suction ability priming pump, including pipe loss, max.	kPa	20	20	20	20	20	20
Temperature before bearings, nom. (TE201)	°C	66	66	66	66	66	66
Temperature after engine, approx.	°C	78	78	78	78	78	78
Pump capacity (main), engine driven	m³/h	34	48	34	34	48	34
Priming pump capacity, 50Hz/60Hz	m³/h	8.6 / 10.5	8.6 / 10.5	8.6 / 10.5	8.6 / 10.5	8.6 / 10.5	8.6 / 10.5
Oil volume, wet sump	m³	0.38	0.5	0.5	0.38	0.5	0.5
Oil volume in separate system oil tank	m³	1.8	1.8	1.8	1.8	1.8	1.8
Filter fineness, nom.	mi- crons	25	25	25	25	25	25
Oil consumption at 100% load, max.	g/kWh	0.35	0.35	0.35	0.35	0.35	0.35
Crankcase ventilation flow rate at 100% load	l/min	780	780	780	780	780	780
Crankcase ventilation backpressure, max.	kPa	0.3	0.3	0.3	0.3	0.3	0.3
Oil volume in speed governor	liters	1.4...2.2	1.4...2.2	1.4...2.2	1.4...2.2	1.4...2.2	1.4...2.2
Cooling water system							
High temperature cooling water system							
Pressure at engine, after pump, nom. (PT401)	kPa	200 + static	200 + static	200 + static	200 + static	200 + static	200 + static
Pressure at engine, after pump, max. (PT401)	kPa	500	350	500	500	350	500
Temperature before cylinder, approx. (TE401)	°C	83	83	83	83	83	83
Temperature after engine, nom.	°C	91	91	91	91	91	91

Wärtsilä 6L20		AE/DE LFO Optimized	ME LFO Optimized	ME LFO Optimized	AE/DE HFO Optimized	ME HFO Optimized	ME HFO Optimized
Cylinder output	kW	220	220	220	220	220	220
Engine speed	RPM	1200	1200	1200	1200	1200	1200
Speed mode		Constant	Variable	Constant	Constant	Variable	Constant
Capacity of engine driven pump, nom.	m ³ /h	30	30	30	30	30	30
Pressure drop over engine, total	kPa	90	90	90	90	90	90
Pressure drop in external system, max.	kPa	120	120	120	120	120	120
Water volume in engine	m ³	0.12	0.12	0.12	0.12	0.12	0.12
Pressure from expansion tank	kPa	70...150	70...150	70...150	70...150	70...150	70...150
Low temperature cooling water system							
Pressure at engine, after pump, nom. (PT451)	kPa	200 + static	200 + static	200 + static	200 + static	200 + static	200 + static
Pressure at engine, after pump, max. (PT451)	kPa	500	350	500	500	350	500
Temperature before engine, min...max	°C	25...38	25...38	25...38	25...38	25...38	25...38
Capacity of engine driven pump, nom.	m ³ /h	39	39	39	39	39	39
Pressure drop over charge air cooler	kPa	30	30	30	30	30	30
Pressure drop over oil cooler	kPa	30	30	30	30	30	30
Pressure drop in external system, max.	kPa	120	120	120	120	120	120
Pressure from expansion tank	kPa	70...150	70...150	70...150	70...150	70...150	70...150
Starting air system							
Pressure, nom.	kPa	3000	3000	3000	3000	3000	3000
Pressure, max.	kPa	3000	3000	3000	3000	3000	3000
Low pressure limit in air vessels	kPa	1800	1800	1800	1800	1800	1800
Starting air consumption, start (successful)	Nm ³	1.2	1.2	1.2	1.2	1.2	1.2

Notes:

- Note 1 At ISO 15550 conditions (ambient air temperature 25°C, LT-water 25°C) and 100% load. Flow tolerance 5%.
- Note 2 At ISO 15550 conditions (ambient air temperature 25°C, LT-water 25°C). Flow tolerance 5% and temperature tolerance 15°C.
Also it's possible to have higher than "max" backpressure shown above, please contact Wärtsilä for additional information.
- Note 3 At ISO 15550 conditions (ambient air temperature 25°C, LT-water 25°C) and 100% load. Tolerance for cooling water heat 10%, tolerance for radiation heat 30%. Fouling factors and a margin to be taken into account when dimensioning heat exchangers.
- Note 4 At ambient conditions according to ISO 15550. Lower calorific value 42 700 kJ/kg. With engine driven pumps (two cooling water + one lubricating oil pump). Tolerance 5%.

ME = Engine driving propeller, variable speed

AE = Auxiliary engine driving generator

DE = Diesel-Electric engine driving generator

Subject to revision without notice.

3.4 Wärtsilä 8L20

3.4.1 IMO Tier 2

Wärtsilä 8L20		AE/DE	AE/DE	AE/DE LFO Op- timized	AE/DE HFO Op- timized	ME	ME LFO Op- timized	ME HFO Op- timized	ME	ME LFO Op- timized	ME HFO Op- timized
Cylinder output	kW	185	200	220	220	200	220	220	200	220	220
Engine speed	RPM	900	1000	1200	1200	1000	1200	1200	1000	1200	1200
Speed mode		Constant	Constant	Constant	Constant	Variable	Variable	Variable	Constant	Constant	Constant
Engine output	kW	1480	1600	1760	1760	1600	1760	1760	1600	1760	1760
Mean effective pressure	MPa	2.8	2.73	2.5	2.5	2.73	2.5	2.5	2.73	2.5	2.5
Combustion air system (Note 1)											
Flow at 100% load	kg/s	2.8	3.03	3.58	3.58	3.03	3.74	3.74	3.03	3.58	3.58
Temperature at turbocharger intake, max.	°C	45	45	45	45	45	45	45	45	45	45
Temperature after air cooler (TE601)	°C	50...70	50...70	50...70	50...70	50...70	50...70	50...70	50...70	50...70	50...70
Exhaust gas system (Note 2)											
Flow at 100% load	kg/s	2.88	3.12	3.68	3.68	3.12	3.84	3.84	3.12	3.68	3.68
Flow at 85% load	kg/s	2.64	2.88	3.12	3.12	2.8	3.2	3.2	2.88	3.12	3.12
Flow at 75% load	kg/s	2.32	2.56	2.8	2.8	2.4	2.72	2.72	2.56	2.8	2.8
Flow at 50% load	kg/s	1.68	1.84	2.0	2.0	1.6	1.84	1.84	1.84	2.0	2.0
Temperature after turbocharger, 100% load (TE517)	°C	363	356	320	320	363	319	319	356	320	320
Temperature after turbocharger, 85% load (TE517)	°C	328	328	325	325	330	313	313	328	325	325
Temperature after turbocharger, 75% load (TE517)	°C	328	328	330	330	340	329	329	328	330	330
Temperature after turbocharger, 50% load (TE517)	°C	348	348	367	367	368	333	333	348	367	367
Backpressure, max.	kPa	5.0	5.0	5.0	5.0	5.0	5.0	5.0	5.0	5.0	5.0
Calculated pipe diameter for 35 m/s	mm	433	449	473	473	451	483	483	449	473	473
Heat balance (Note 3)											
Jacket water, HT-circuit	kW	320	336	392	392	336	392	392	336	392	392
Charge air, LT-circuit	kW	496	544	624	624	544	704	704	544	624	624
Lubricating oil, LT-circuit	kW	232	248	208	208	248	216	216	248	208	208
Radiation	kW	64	64	63	63	64	63	63	64	63	63
Fuel system (Note 4)											
Pressure before injection pumps (PT101)	kPa	700±50	700±50	700±50	700±50	700±50	700±50	700±50	700±50	700±50	700±50
Pressure before engine driven fuel feed pump, min. (MDF only)	kPa	15	15	15	15	15	15	15	15	15	15
Engine driven pump capacity (MDF only)	m³/h	1.73	1.92	1.7	n/a	1.92	1.7	n/a	1.92	1.7	n/a
Fuel flow to engine (without engine driven pump), approx.	m³/h	1.59	1.74	n/a	1.98	1.74	n/a	2.02	1.74	n/a	2.02
HFO viscosity before engine	cSt	16... 24	16... 24	n/a	16... 24	16... 24	n/a	16... 24	16... 24	n/a	16... 24

Wärtsilä 8L20		AE/DE	AE/DE	AE/DE LFO Op- timized	AE/DE HFO Op- timized	ME	ME LFO Op- timized	ME HFO Op- timized	ME	ME LFO Op- timized	ME HFO Op- timized
Cylinder output	kW	185	200	220	220	200	220	220	200	220	220
Engine speed	RPM	900	1000	1200	1200	1000	1200	1200	1000	1200	1200
Speed mode		Constant	Constant	Constant	Constant	Variable	Variable	Variable	Constant	Constant	Constant
Max. HFO temperature before engine (TE101)	°C	140	140	n/a	140	140	n/a	140	140	n/a	140
MDF viscosity, min.	cSt	1.8	1.8	1.8	1.8	1.8	1.8	1.8	1.8	1.8	1.8
Max. MDF temperature before engine (TE101)	°C	45	45	45	45	45	45	45	45	45	45
Fuel consumption at 100% load, HFO	g/kWh	194.4	196.3	n/a	203.7	196.3	n/a	207.3	196.3	n/a	207.3
Fuel consumption at 85% load, HFO	g/kWh	191.5	193.0	n/a	200.1	191.6	n/a	201.8	193.5	n/a	203.0
Fuel consumption at 75% load, HFO	g/kWh	191.2	193.5	n/a	200.9	191.1	n/a	199.2	194.0	n/a	203.5
Fuel consumption at 50% load, HFO	g/kWh	199.0	201.0	n/a	211.0	195.1	n/a	197.3	201.5	n/a	212.6
Fuel consumption at 100% load, MDF	g/kWh	193.4	195.3	201.7	203.6	195.3	205.3	208.1	195.3	205.3	207.2
Fuel consumption at 85% load, MDF	g/kWh	190.7	192.2	199.2	200.7	190.8	199.5	201.7	192.7	201.7	203.1
Fuel consumption at 75% load, MDF	g/kWh	190.6	192.8	200.1	201.2	190.4	197.3	199.2	193.2	202.4	203.5
Fuel consumption at 50% load, MDF	g/kWh	198.5	200.6	210.6	211.0	194.7	194.8	195.7	201.0	211.9	212.4
Clean leak fuel quantity, MDF at 100% load	kg/h	4.32	4.32	4.32	4.32	4.32	4.32	4.32	4.32	4.32	4.32
Lubricating oil system											
Pressure before bearings, nom. (PT201)	kPa	450	450	450	450	450	450	450	450	450	450
Suction ability main pump, including pipe loss, max.	kPa	20	20	20	20	20	20	20	20	20	20
Priming pressure, nom. (PT201)	kPa	80	80	80	80	80	80	80	80	80	80
Suction ability priming pump, including pipe loss, max.	kPa	20	20	20	20	20	20	20	20	20	20
Temperature before bearings, nom. (TE201)	°C	66	66	66	66	66	66	66	66	66	66
Temperature after engine, approx.	°C	78	78	78	78	78	78	78	78	78	78
Pump capacity (main), engine driven	m³/h	43	48	48	48	64	64	64	48	48	48
Priming pump capacity, 50Hz/60Hz	m³/h	8.6 / 10.5	8.6 / 10.5	8.6 / 10.5	8.6 / 10.5	8.6 / 10.5	8.6 / 10.5	8.6 / 10.5	8.6 / 10.5	8.6 / 10.5	8.6 / 10.5
Oil volume, wet sump	m³	0.49	0.49	0.49	0.49	0.64	0.64	0.64	0.64	0.64	0.64
Oil volume in separate system oil tank	m³	2.0	2.2	2.4	2.4	2.2	2.4	2.4	2.2	2.4	2.4
Filter fineness, nom.	microns	25	25	25	25	25	25	25	25	25	25
Oil consumption at 100% load, max.	g/kWh	0.5	0.5	0.35	0.35	0.5	0.35	0.35	0.5	0.35	0.35
Crankcase ventilation flow rate at 100% load	l/min	1040	1040	1040	1040	1040	1040	1040	1040	1040	1040
Crankcase ventilation backpressure, max.	kPa	0.3	0.3	0.3	0.3	0.3	0.3	0.3	0.3	0.3	0.3
Oil volume in speed governor	liters	1.4...2.2	1.4...2.2	1.4...2.2	1.4...2.2	1.4...2.2	1.4...2.2	1.4...2.2	1.4...2.2	1.4...2.2	1.4...2.2
Cooling water system											
High temperature cooling water system											
Pressure at engine, after pump, nom. (PT401)	kPa	200 + static	200 + static	200 + static	200 + static	200 + static	200 + static	200 + static	200 + static	200 + static	200 + static
Pressure at engine, after pump, max. (PT401)	kPa	500	500	500	500	350	350	350	500	500	500

Wärtsilä 8L20		AE/DE	AE/DE	AE/DE LFO Op- timized	AE/DE HFO Op- timized	ME	ME LFO Op- timized	ME HFO Op- timized	ME	ME LFO Op- timized	ME HFO Op- timized
Cylinder output	kW	185	200	220	220	200	220	220	200	220	220
Engine speed	RPM	900	1000	1200	1200	1000	1200	1200	1000	1200	1200
Speed mode		Constant	Constant	Constant	Constant	Variable	Variable	Variable	Constant	Constant	Constant
Temperature before cylinder, approx. (TE401)	°C	83	83	83	83	83	83	83	83	83	83
Temperature after engine, nom.	°C	91	91	91	91	91	91	91	91	91	91
Capacity of engine driven pump, nom.	m ³ /h	39	40	41	41	40	41	41	40	41	41
Pressure drop over engine, total	kPa	90	90	90	90	90	90	90	90	90	90
Pressure drop in external system, max.	kPa	120	120	120	120	120	120	120	120	120	120
Water volume in engine	m ³	0.15	0.15	0.15	0.15	0.15	0.15	0.15	0.15	0.15	0.15
Pressure from expansion tank	kPa	70...150	70...150	70...150	70...150	70...150	70...150	70...150	70...150	70...150	70...150
Low temperature cooling water system											
Pressure at engine, after pump, nom. (PT451)	kPa	200 + static	200 + static	200 + static	200 + static	200 + static	200 + static	200 + static	200 + static	200 + static	200 + static
Pressure at engine, after pump, max. (PT451)	kPa	500	500	500	500	350	350	350	500	500	500
Temperature before engine, min...max	°C	25...38	25...38	25...38	25...38	25...38	25...38	25...38	25...38	25...38	25...38
Capacity of engine driven pump, nom.	m ³ /h	45	48	51	51	48	51	51	48	51	51
Pressure drop over charge air cooler	kPa	30	30	30	30	30	30	30	30	30	30
Pressure drop over oil cooler	kPa	30	30	30	30	30	30	30	30	30	30
Pressure drop in external system, max.	kPa	120	120	120	120	120	120	120	120	120	120
Pressure from expansion tank	kPa	70...150	70...150	70...150	70...150	70...150	70...150	70...150	70...150	70...150	70...150
Starting air system											
Pressure, nom.	kPa	3000	3000	3000	3000	3000	3000	3000	3000	3000	3000
Pressure, max.	kPa	3000	3000	3000	3000	3000	3000	3000	3000	3000	3000
Low pressure limit in air vessels	kPa	1800	1800	1800	1800	1800	1800	1800	1800	1800	1800
Starting air consumption, start (successful)	Nm ³	1.2	1.2	1.2	1.2	1.2	1.2	1.2	1.2	1.2	1.2

Notes:

- Note 1 At ISO 15550 conditions (ambient air temperature 25°C, LT-water 25°C) and 100% load. Flow tolerance 5%.
- Note 2 At ISO 15550 conditions (ambient air temperature 25°C, LT-water 25°C). Flow tolerance 5% and temperature tolerance 15°C.
Also it's possible to have higher than "max" backpressure shown above, please contact Wärtsilä for additional information.
- Note 3 At ISO 15550 conditions (ambient air temperature 25°C, LT-water 25°C) and 100% load. Tolerance for cooling water heat 10%, tolerance for radiation heat 30%. Fouling factors and a margin to be taken into account when dimensioning heat exchangers.
- Note 4 At ambient conditions according to ISO 15550. Lower calorific value 42 700 kJ/kg. With engine driven pumps (two cooling water + one lubricating oil pump). Tolerance 5%.

ME = Engine driving propeller, variable speed

AE = Auxiliary engine driving generator

DE = Diesel-Electric engine driving generator

Subject to revision without notice.

3.4.2 SCR Ready

3.4.2.1 900 & 1000 rpm

Wärtsilä 8L20		AE/DE	AE/DE	ME	ME
Cylinder output	kW	185	200	200	200
Engine speed	RPM	900	1000	1000	1000
Speed mode		Constant	Constant	Variable	Constant
Engine output	kW	1480	1600	1600	1600
Mean effective pressure	MPa	2.8	2.73	2.73	2.73
Combustion air system (Note 1)					
Flow at 100% load	kg/s	2.8	3.03	3.03	3.03
Temperature at turbocharger intake, max.	°C	45	45	45	45
Temperature after air cooler (TE601)	°C	50...70	50...70	50...70	50...70
Exhaust gas system (Note 2)					
Flow at 100% load	kg/s	2.88	3.12	3.12	3.12
Flow at 85% load	kg/s	2.48	2.8	2.72	2.8
Flow at 75% load	kg/s	2.16	2.48	2.4	2.48
Flow at 50% load	kg/s	1.6	1.6	1.6	1.6
Temperature after turbocharger, 100% load (TE517)	°C	363	358	363	358
Temperature after turbocharger, 85% load (TE517)	°C	340	340	340	340
Temperature after turbocharger, 75% load (TE517)	°C	340	340	340	340
Temperature after turbocharger, 50% load (TE517)	°C	348	348	368	348
Backpressure, max.	kPa	5.0	5.0	5.0	5.0
Calculated pipe diameter for 35 m/s	mm	433	449	451	449
Heat balance (Note 3)					
Jacket water, HT-circuit	kW	320	336	336	336
Charge air, LT-circuit	kW	496	544	544	544
Lubricating oil, LT-circuit	kW	224	248	248	248
Radiation	kW	64	64	64	64
Fuel system (Note 4)					
Pressure before injection pumps (PT101)	kPa	700±50	700±50	700±50	700±50
Pressure before engine driven fuel feed pump, min. (MDF only)	kPa	15	15	15	15
Engine driven pump capacity (MDF only)	m³/h	1.73	1.92	1.92	1.92
Fuel flow to engine (without engine driven pump), approx.	m³/h	1.6	1.74	1.74	1.74
HFO viscosity before engine	cSt	16... 24	16... 24	16... 24	16... 24
Max. HFO temperature before engine (TE101)	°C	140	140	140	140

Wärtsilä 8L20		AE/DE	AE/DE	ME	ME
Cylinder output	kW	185	200	200	200
Engine speed	RPM	900	1000	1000	1000
Speed mode		Constant	Constant	Variable	Constant
MDF viscosity, min.	cSt	1.8	1.8	1.8	1.8
Max. MDF temperature before engine (TE101)	°C	45	45	45	45
Fuel consumption at 100% load, HFO	g/kWh	195.2	196.7	196.3	196.3
Fuel consumption at 85% load, HFO	g/kWh	193.6	195.3	193.1	195.3
Fuel consumption at 75% load, HFO	g/kWh	192.8	195.4	192.6	195.4
Fuel consumption at 50% load, HFO	g/kWh	199.0	201.0	195.1	201.5
Fuel consumption at 100% load, MDF	g/kWh	194.3	195.7	195.3	195.3
Fuel consumption at 85% load, MDF	g/kWh	192.8	194.5	192.3	194.5
Fuel consumption at 75% load, MDF	g/kWh	192.1	194.7	191.8	194.7
Fuel consumption at 50% load, MDF	g/kWh	198.5	200.6	194.7	201.0
Clean leak fuel quantity, MDF at 100% load	kg/h	4.32	4.32	4.32	4.32
Lubricating oil system					
Pressure before bearings, nom. (PT201)	kPa	450	450	450	450
Suction ability main pump, including pipe loss, max.	kPa	20	20	20	20
Priming pressure, nom. (PT201)	kPa	80	80	80	80
Suction ability priming pump, including pipe loss, max.	kPa	20	20	20	20
Temperature before bearings, nom. (TE201)	°C	66	66	66	66
Temperature after engine, approx.	°C	78	78	78	78
Pump capacity (main), engine driven	m³/h	43	48	64	48
Priming pump capacity, 50Hz/60Hz	m³/h	8.6 / 10.5	8.6 / 10.5	8.6 / 10.5	8.6 / 10.5
Oil volume, wet sump	m³	0.49	0.49	0.64	0.64
Oil volume in separate system oil tank	m³	2.0	2.2	2.2	2.2
Filter fineness, nom.	mi-crons	25	25	25	25
Oil consumption at 100% load, max.	g/kWh	0.5	0.5	0.5	0.5
Crankcase ventilation flow rate at 100% load	l/min	1040	1040	1040	1040
Crankcase ventilation backpressure, max.	kPa	0.3	0.3	0.3	0.3
Oil volume in speed governor	liters	1.4...2.2	1.4...2.2	1.4...2.2	1.4...2.2
Cooling water system					
High temperature cooling water system					
Pressure at engine, after pump, nom. (PT401)	kPa	200 + static	200 + static	200 + static	200 + static
Pressure at engine, after pump, max. (PT401)	kPa	500	500	350	500
Temperature before cylinder, approx. (TE401)	°C	83	83	83	83
Temperature after engine, nom.	°C	91	91	91	91
Capacity of engine driven pump, nom.	m³/h	39	40	40	40

Wärtsilä 8L20		AE/DE	AE/DE	ME	ME
Cylinder output	kW	185	200	200	200
Engine speed	RPM	900	1000	1000	1000
Speed mode		Constant	Constant	Variable	Constant
Pressure drop over engine, total	kPa	90	90	90	90
Pressure drop in external system, max.	kPa	120	120	120	120
Water volume in engine	m ³	0.15	0.15	0.15	0.15
Pressure from expansion tank	kPa	70...150	70...150	70...150	70...150
Low temperature cooling water system					
Pressure at engine, after pump, nom. (PT451)	kPa	200 + static	200 + static	200 + static	200 + static
Pressure at engine, after pump, max. (PT451)	kPa	500	500	350	500
Temperature before engine, min...max	°C	25...38	25...38	25...38	25...38
Capacity of engine driven pump, nom.	m ³ /h	45	48	48	48
Pressure drop over charge air cooler	kPa	30	30	30	30
Pressure drop over oil cooler	kPa	30	30	30	30
Pressure drop in external system, max.	kPa	120	120	120	120
Pressure from expansion tank	kPa	70...150	70...150	70...150	70...150
Starting air system					
Pressure, nom.	kPa	3000	3000	3000	3000
Pressure, max.	kPa	3000	3000	3000	3000
Low pressure limit in air vessels	kPa	1800	1800	1800	1800
Starting air consumption, start (successful)	Nm ³	1.2	1.2	1.2	1.2

Notes:

- Note 1 At ISO 15550 conditions (ambient air temperature 25°C, LT-water 25°C) and 100% load. Flow tolerance 5%.
- Note 2 At ISO 15550 conditions (ambient air temperature 25°C, LT-water 25°C). Flow tolerance 5% and temperature tolerance 15°C.
Also it's possible to have higher than "max" backpressure shown above, please contact Wärtsilä for additional information.
- Note 3 At ISO 15550 conditions (ambient air temperature 25°C, LT-water 25°C) and 100% load. Tolerance for cooling water heat 10%, tolerance for radiation heat 30%. Fouling factors and a margin to be taken into account when dimensioning heat exchangers.
- Note 4 At ambient conditions according to ISO 15550. Lower calorific value 42 700 kJ/kg. With engine driven pumps (two cooling water + one lubricating oil pump). Tolerance 5%.

ME = Engine driving propeller, variable speed

AE = Auxiliary engine driving generator

DE = Diesel-Electric engine driving generator

Subject to revision without notice.

3.4.2.2 1200 rpm fuel sulphur content ≤ 0,5%

Wärtsilä 8L20		AE/DE LFO Op- timized	ME LFO Op- timized	ME LFO Op- timized	AE/DE HFO Op- timized	ME HFO Op- timized	ME HFO Op- timized
Cylinder output	kW	220	220	220	220	220	220
Engine speed	RPM	1200	1200	1200	1200	1200	1200
Speed mode		Constant	Variable	Constant	Constant	Variable	Constant
Engine output	kW	1760	1760	1760	1760	1760	1760
Mean effective pressure	MPa	2.5	2.5	2.5	2.5	2.5	2.5
Combustion air system (Note 1)							
Flow at 100% load	kg/s	3.58	3.74	3.58	3.58	3.74	3.58
Temperature at turbocharger intake, max.	°C	45	45	45	45	45	45
Temperature after air cooler (TE601)	°C	50...70	50...70	50...70	50...70	50...70	50...70
Exhaust gas system (Note 2)							
Flow at 100% load	kg/s	3.68	3.84	3.68	3.68	3.84	3.68
Flow at 85% load	kg/s	3.12	3.12	3.12	3.12	3.12	3.12
Flow at 75% load	kg/s	2.8	2.72	2.8	2.8	2.72	2.8
Flow at 50% load	kg/s	2.0	1.84	2.0	2.0	1.84	2.0
Temperature after turbocharger, 100% load (TE517)	°C	320	320	320	320	320	320
Temperature after turbocharger, 85% load (TE517)	°C	325	320	325	325	320	325
Temperature after turbocharger, 75% load (TE517)	°C	330	329	330	330	329	330
Temperature after turbocharger, 50% load (TE517)	°C	367	333	367	367	333	367
Backpressure, max.	kPa	5.0	5.0	5.0	5.0	5.0	5.0
Calculated pipe diameter for 35 m/s	mm	473	483	473	473	483	473
Heat balance (Note 3)							
Jacket water, HT-circuit	kW	392	392	392	392	392	392
Charge air, LT-circuit	kW	624	704	624	624	704	624
Lubricating oil, LT-circuit	kW	208	216	208	208	216	208
Radiation	kW	63	63	63	63	63	63
Fuel system (Note 4)							
Pressure before injection pumps (PT101)	kPa	700±50	700±50	700±50	700±50	700±50	700±50
Pressure before engine driven fuel feed pump, min. (MDF only)	kPa	15	15	15	15	15	15
Engine driven pump capacity (MDF only)	m³/h	1.7	1.7	1.7	n/a	n/a	n/a
Fuel flow to engine (without engine driven pump), approx.	m³/h	n/a	n/a	n/a	1.98	2.02	2.02
HFO viscosity before engine	cSt	n/a	n/a	n/a	16... 24	16... 24	16... 24
Max. HFO temperature before engine (TE101)	°C	n/a	n/a	n/a	140	140	140
MDF viscosity, min.	cSt	1.8	1.8	1.8	1.8	1.8	1.8

Wärtsilä 8L20		AE/DE LFO Optimized	ME LFO Optimized	ME LFO Optimized	AE/DE HFO Optimized	ME HFO Optimized	ME HFO Optimized
Cylinder output	kW	220	220	220	220	220	220
Engine speed	RPM	1200	1200	1200	1200	1200	1200
Speed mode		Constant	Variable	Constant	Constant	Variable	Constant
Max. MDF temperature before engine (TE101)	°C	45	45	45	45	45	45
Fuel consumption at 100% load, HFO	g/kWh	n/a	n/a	n/a	203.7	207.3	207.3
Fuel consumption at 85% load, HFO	g/kWh	n/a	n/a	n/a	200.1	201.8	203.0
Fuel consumption at 75% load, HFO	g/kWh	n/a	n/a	n/a	200.9	199.2	203.5
Fuel consumption at 50% load, HFO	g/kWh	n/a	n/a	n/a	211.0	197.3	212.6
Fuel consumption at 100% load, MDF	g/kWh	201.7	205.3	205.3	203.6	208.1	207.2
Fuel consumption at 85% load, MDF	g/kWh	199.2	199.5	201.7	200.7	201.9	203.1
Fuel consumption at 75% load, MDF	g/kWh	200.1	197.3	202.4	201.2	199.2	203.5
Fuel consumption at 50% load, MDF	g/kWh	210.6	194.8	211.9	211.0	195.7	213.7
Clean leak fuel quantity, MDF at 100% load	kg/h	4.32	4.32	4.32	4.32	4.32	4.32
Lubricating oil system							
Pressure before bearings, nom. (PT201)	kPa	450	450	450	450	450	450
Suction ability main pump, including pipe loss, max.	kPa	20	20	20	20	20	20
Priming pressure, nom. (PT201)	kPa	80	80	80	80	80	80
Suction ability priming pump, including pipe loss, max.	kPa	20	20	20	20	20	20
Temperature before bearings, nom. (TE201)	°C	66	66	66	66	66	66
Temperature after engine, approx.	°C	78	78	78	78	78	78
Pump capacity (main), engine driven	m³/h	48	64	48	48	64	48
Priming pump capacity, 50Hz/60Hz	m³/h	8.6 / 10.5	8.6 / 10.5	8.6 / 10.5	8.6 / 10.5	8.6 / 10.5	8.6 / 10.5
Oil volume, wet sump	m³	0.49	0.64	0.64	0.49	0.64	0.64
Oil volume in separate system oil tank	m³	2.4	2.4	2.4	2.4	2.4	2.4
Filter fineness, nom.	microns	25	25	25	25	25	25
Oil consumption at 100% load, max.	g/kWh	0.35	0.35	0.35	0.35	0.35	0.35
Crankcase ventilation flow rate at 100% load	l/min	1040	1040	1040	1040	1040	1040
Crankcase ventilation backpressure, max.	kPa	0.3	0.3	0.3	0.3	0.3	0.3
Oil volume in speed governor	liters	1.4...2.2	1.4...2.2	1.4...2.2	1.4...2.2	1.4...2.2	1.4...2.2
Cooling water system							
High temperature cooling water system							
Pressure at engine, after pump, nom. (PT401)	kPa	200 + static	200 + static	200 + static	200 + static	200 + static	200 + static
Pressure at engine, after pump, max. (PT401)	kPa	500	350	500	500	350	500
Temperature before cylinder, approx. (TE401)	°C	83	83	83	83	83	83
Temperature after engine, nom.	°C	91	91	91	91	91	91

Wärtsilä 8L20		AE/DE LFO Op- timized	ME LFO Op- timized	ME LFO Op- timized	AE/DE HFO Op- timized	ME HFO Op- timized	ME HFO Op- timized
Cylinder output	kW	220	220	220	220	220	220
Engine speed	RPM	1200	1200	1200	1200	1200	1200
Speed mode		Constant	Variable	Constant	Constant	Variable	Constant
Capacity of engine driven pump, nom.	m ³ /h	41	41	41	41	41	41
Pressure drop over engine, total	kPa	90	90	90	90	90	90
Pressure drop in external system, max.	kPa	120	120	120	120	120	120
Water volume in engine	m ³	0.15	0.15	0.15	0.15	0.15	0.15
Pressure from expansion tank	kPa	70...150	70...150	70...150	70...150	70...150	70...150
Low temperature cooling water system							
Pressure at engine, after pump, nom. (PT451)	kPa	200 + static	200 + static	200 + static	200 + static	200 + static	200 + static
Pressure at engine, after pump, max. (PT451)	kPa	500	350	500	500	350	500
Temperature before engine, min...max	°C	25...38	25...38	25...38	25...38	25...38	25...38
Capacity of engine driven pump, nom.	m ³ /h	51	51	51	51	51	51
Pressure drop over charge air cooler	kPa	30	30	30	30	30	30
Pressure drop over oil cooler	kPa	30	30	30	30	30	30
Pressure drop in external system, max.	kPa	120	120	120	120	120	120
Pressure from expansion tank	kPa	70...150	70...150	70...150	70...150	70...150	70...150
Starting air system							
Pressure, nom.	kPa	3000	3000	3000	3000	3000	3000
Pressure, max.	kPa	3000	3000	3000	3000	3000	3000
Low pressure limit in air vessels	kPa	1800	1800	1800	1800	1800	1800
Starting air consumption, start (successful)	Nm ³	1.2	1.2	1.2	1.2	1.2	1.2

Notes:

- Note 1 At ISO 15550 conditions (ambient air temperature 25°C, LT-water 25°C) and 100% load. Flow tolerance 5%.
- Note 2 At ISO 15550 conditions (ambient air temperature 25°C, LT-water 25°C). Flow tolerance 5% and temperature tolerance 15°C.
Also it's possible to have higher than "max" backpressure shown above, please contact Wärtsilä for additional information.
- Note 3 At ISO 15550 conditions (ambient air temperature 25°C, LT-water 25°C) and 100% load. Tolerance for cooling water heat 10%, tolerance for radiation heat 30%. Fouling factors and a margin to be taken into account when dimensioning heat exchangers.
- Note 4 At ambient conditions according to ISO 15550. Lower calorific value 42 700 kJ/kg. With engine driven pumps (two cooling water + one lubricating oil pump). Tolerance 5%.

ME = Engine driving propeller, variable speed

AE = Auxiliary engine driving generator

DE = Diesel-Electric engine driving generator

Subject to revision without notice.

3.4.2.3 1200 rpm fuel sulphur content > 0,5%

Wärtsilä 8L20		AE/DE LFO Optimized	ME LFO Optimized	ME LFO Optimized	AE/DE HFO Optimized	ME HFO Optimized	ME HFO Optimized
Cylinder output	kW	220	220	220	220	220	220
Engine speed	RPM	1200	1200	1200	1200	1200	1200
Speed mode		Constant	Variable	Constant	Constant	Variable	Constant
Engine output	kW	1760	1760	1760	1760	1760	1760
Mean effective pressure	MPa	2.5	2.5	2.5	2.5	2.5	2.5
Combustion air system (Note 1)							
Flow at 100% load	kg/s	3.34	3.5	3.34	3.34	3.5	3.34
Temperature at turbocharger intake, max.	°C	45	45	45	45	45	45
Temperature after air cooler (TE601)	°C	50...70	50...70	50...70	50...70	50...70	50...70
Exhaust gas system (Note 2)							
Flow at 100% load	kg/s	3.44	3.6	3.44	3.44	3.6	3.44
Flow at 85% load	kg/s	2.88	3.04	2.88	2.88	3.04	2.88
Flow at 75% load	kg/s	2.64	2.64	2.64	2.64	2.64	2.64
Flow at 50% load	kg/s	2.0	1.84	2.0	2.0	1.84	2.0
Temperature after turbocharger, 100% load (TE517)	°C	340	340	340	340	340	340
Temperature after turbocharger, 85% load (TE517)	°C	340	340	340	340	340	340
Temperature after turbocharger, 75% load (TE517)	°C	340	340	340	340	340	340
Temperature after turbocharger, 50% load (TE517)	°C	367	340	367	367	340	367
Backpressure, max.	kPa	5.0	5.0	5.0	5.0	5.0	5.0
Calculated pipe diameter for 35 m/s	mm	465	476	465	465	476	465
Heat balance (Note 3)							
Jacket water, HT-circuit	kW	432	424	432	432	424	432
Charge air, LT-circuit	kW	624	704	624	624	704	624
Lubricating oil, LT-circuit	kW	216	224	216	216	224	216
Radiation	kW	65	65	65	65	65	65
Fuel system (Note 4)							
Pressure before injection pumps (PT101)	kPa	700±50	700±50	700±50	700±50	700±50	700±50
Pressure before engine driven fuel feed pump, min. (MDF only)	kPa	15	15	15	15	15	15
Engine driven pump capacity (MDF only)	m³/h	1.7	1.7	1.7	n/a	n/a	n/a
Fuel flow to engine (without engine driven pump), approx.	m³/h	n/a	n/a	n/a	2.0	2.02	2.02
HFO viscosity before engine	cSt	n/a	n/a	n/a	16... 24	16... 24	16... 24
Max. HFO temperature before engine (TE101)	°C	n/a	n/a	n/a	140	140	140
MDF viscosity, min.	cSt	1.8	1.8	1.8	1.8	1.8	1.8

Wärtsilä 8L20		AE/DE LFO Op- timized	ME LFO Op- timized	ME LFO Op- timized	AE/DE HFO Op- timized	ME HFO Op- timized	ME HFO Op- timized
Cylinder output	kW	220	220	220	220	220	220
Engine speed	RPM	1200	1200	1200	1200	1200	1200
Speed mode		Constant	Variable	Constant	Constant	Variable	Constant
Max. MDF temperature before engine (TE101)	°C	45	45	45	45	45	45
Fuel consumption at 100% load, HFO	g/kWh	n/a	n/a	n/a	205.6	207.8	207.8
Fuel consumption at 85% load, HFO	g/kWh	n/a	n/a	n/a	201.5	202.4	204.5
Fuel consumption at 75% load, HFO	g/kWh	n/a	n/a	n/a	201.6	199.2	204.3
Fuel consumption at 50% load, HFO	g/kWh	n/a	n/a	n/a	211.0	197.3	212.6
Fuel consumption at 100% load, MDF	g/kWh	203.6	205.8	205.8	205.7	210.4	209.5
Fuel consumption at 85% load, MDF	g/kWh	200.7	200.1	203.1	203.4	203.8	205.7
Fuel consumption at 75% load, MDF	g/kWh	200.9	197.3	203.1	204.1	200.3	206.0
Fuel consumption at 50% load, MDF	g/kWh	210.6	194.8	211.9	211.0	196.3	213.7
Clean leak fuel quantity, MDF at 100% load	kg/h	4.32	4.32	4.32	4.32	4.32	4.32
Lubricating oil system							
Pressure before bearings, nom. (PT201)	kPa	450	450	450	450	450	450
Suction ability main pump, including pipe loss, max.	kPa	20	20	20	20	20	20
Priming pressure, nom. (PT201)	kPa	80	80	80	80	80	80
Suction ability priming pump, including pipe loss, max.	kPa	20	20	20	20	20	20
Temperature before bearings, nom. (TE201)	°C	66	66	66	66	66	66
Temperature after engine, approx.	°C	78	78	78	78	78	78
Pump capacity (main), engine driven	m³/h	48	64	48	48	64	48
Priming pump capacity, 50Hz/60Hz	m³/h	8.6 / 10.5	8.6 / 10.5	8.6 / 10.5	8.6 / 10.5	8.6 / 10.5	8.6 / 10.5
Oil volume, wet sump	m³	0.49	0.64	0.64	0.49	0.64	0.64
Oil volume in separate system oil tank	m³	2.4	2.4	2.4	2.4	2.4	2.4
Filter fineness, nom.	mi- crons	25	25	25	25	25	25
Oil consumption at 100% load, max.	g/kWh	0.35	0.35	0.35	0.35	0.35	0.35
Crankcase ventilation flow rate at 100% load	l/min	1040	1040	1040	1040	1040	1040
Crankcase ventilation backpressure, max.	kPa	0.3	0.3	0.3	0.3	0.3	0.3
Oil volume in speed governor	liters	1.4...2.2	1.4...2.2	1.4...2.2	1.4...2.2	1.4...2.2	1.4...2.2
Cooling water system							
High temperature cooling water system							
Pressure at engine, after pump, nom. (PT401)	kPa	200 + static	200 + static	200 + static	200 + static	200 + static	200 + static
Pressure at engine, after pump, max. (PT401)	kPa	500	350	500	500	350	500
Temperature before cylinder, approx. (TE401)	°C	83	83	83	83	83	83
Temperature after engine, nom.	°C	91	91	91	91	91	91

Wärtsilä 8L20		AE/DE LFO Optimized	ME LFO Optimized	ME LFO Optimized	AE/DE HFO Optimized	ME HFO Optimized	ME HFO Optimized
Cylinder output	kW	220	220	220	220	220	220
Engine speed	RPM	1200	1200	1200	1200	1200	1200
Speed mode		Constant	Variable	Constant	Constant	Variable	Constant
Capacity of engine driven pump, nom.	m ³ /h	41	41	41	41	41	41
Pressure drop over engine, total	kPa	90	90	90	90	90	90
Pressure drop in external system, max.	kPa	120	120	120	120	120	120
Water volume in engine	m ³	0.15	0.15	0.15	0.15	0.15	0.15
Pressure from expansion tank	kPa	70...150	70...150	70...150	70...150	70...150	70...150
Low temperature cooling water system							
Pressure at engine, after pump, nom. (PT451)	kPa	200 + static	200 + static	200 + static	200 + static	200 + static	200 + static
Pressure at engine, after pump, max. (PT451)	kPa	500	350	500	500	350	500
Temperature before engine, min...max	°C	25...38	25...38	25...38	25...38	25...38	25...38
Capacity of engine driven pump, nom.	m ³ /h	51	51	51	51	51	51
Pressure drop over charge air cooler	kPa	30	30	30	30	30	30
Pressure drop over oil cooler	kPa	30	30	30	30	30	30
Pressure drop in external system, max.	kPa	120	120	120	120	120	120
Pressure from expansion tank	kPa	70...150	70...150	70...150	70...150	70...150	70...150
Starting air system							
Pressure, nom.	kPa	3000	3000	3000	3000	3000	3000
Pressure, max.	kPa	3000	3000	3000	3000	3000	3000
Low pressure limit in air vessels	kPa	1800	1800	1800	1800	1800	1800
Starting air consumption, start (successful)	Nm ³	1.2	1.2	1.2	1.2	1.2	1.2

Notes:

- Note 1 At ISO 15550 conditions (ambient air temperature 25°C, LT-water 25°C) and 100% load. Flow tolerance 5%.
- Note 2 At ISO 15550 conditions (ambient air temperature 25°C, LT-water 25°C). Flow tolerance 5% and temperature tolerance 15°C.
Also it's possible to have higher than "max" backpressure shown above, please contact Wärtsilä for additional information.
- Note 3 At ISO 15550 conditions (ambient air temperature 25°C, LT-water 25°C) and 100% load. Tolerance for cooling water heat 10%, tolerance for radiation heat 30%. Fouling factors and a margin to be taken into account when dimensioning heat exchangers.
- Note 4 At ambient conditions according to ISO 15550. Lower calorific value 42 700 kJ/kg. With engine driven pumps (two cooling water + one lubricating oil pump). Tolerance 5%.

ME = Engine driving propeller, variable speed

AE = Auxiliary engine driving generator

DE = Diesel-Electric engine driving generator

Subject to revision without notice.

3.5 Wärtsilä 9L20

3.5.1 IMO Tier 2

Wärtsilä 9L20		AE/DE	AE/DE	AE/DE LFO Op- timized	AE/DE HFO Op- timized	ME	ME LFO Op- timized	ME HFO Op- timized	ME	ME LFO Op- timized	ME HFO Op- timized
Cylinder output	kW	185	200	220	220	200	220	220	200	220	220
Engine speed	RPM	900	1000	1200	1200	1000	1200	1200	1000	1200	1200
Speed mode		Constant	Constant	Constant	Constant	Variable	Variable	Variable	Constant	Constant	Constant
Engine output	kW	1665	1800	1980	1980	1800	1980	1980	1800	1980	1980
Mean effective pressure	MPa	2.8	2.73	2.5	2.5	2.73	2.5	2.5	2.73	2.5	2.5
Combustion air system (Note 1)											
Flow at 100% load	kg/s	3.15	3.41	4.03	4.03	3.41	4.21	4.21	3.41	4.03	4.03
Temperature at turbocharger intake, max.	°C	45	45	45	45	45	45	45	45	45	45
Temperature after air cooler (TE601)	°C	50...70	50...70	50...70	50...70	50...70	50...70	50...70	50...70	50...70	50...70
Exhaust gas system (Note 2)											
Flow at 100% load	kg/s	3.24	3.51	4.14	4.14	3.51	4.32	4.32	3.51	4.14	4.14
Flow at 85% load	kg/s	2.97	3.24	3.6	3.6	3.15	3.6	3.6	3.24	3.6	3.6
Flow at 75% load	kg/s	2.61	2.88	3.24	3.24	2.7	3.06	3.06	2.88	3.24	3.24
Flow at 50% load	kg/s	1.89	2.07	2.25	2.25	1.8	2.07	2.07	2.07	2.25	2.25
Temperature after turbocharger, 100% load (TE517)	°C	363	356	316	316	363	319	319	356	316	316
Temperature after turbocharger, 85% load (TE517)	°C	328	328	304	304	330	313	313	328	304	304
Temperature after turbocharger, 75% load (TE517)	°C	328	328	307	307	340	329	329	328	307	307
Temperature after turbocharger, 50% load (TE517)	°C	348	348	337	337	368	333	333	348	337	337
Backpressure, max.	kPa	5.0	5.0	5.0	5.0	5.0	5.0	5.0	5.0	5.0	5.0
Calculated pipe diameter for 35 m/s	mm	460	476	500	500	478	512	512	476	500	500
Heat balance (Note 3)											
Jacket water, HT-circuit	kW	360	378	441	441	378	441	441	378	441	441
Charge air, LT-circuit	kW	558	612	702	702	612	792	792	612	702	702
Lubricating oil, LT-circuit	kW	261	279	234	234	279	243	243	279	234	234
Radiation	kW	72	72	71	71	72	71	71	72	71	71
Fuel system (Note 4)											
Pressure before injection pumps (PT101)	kPa	700±50	700±50	700±50	700±50	700±50	700±50	700±50	700±50	700±50	700±50
Pressure before engine driven fuel feed pump, min. (MDF only)	kPa	15	15	15	15	15	15	15	15	15	15
Engine driven pump capacity (MDF only)	m³/h	1.73	1.92	2.0	n/a	1.92	2.0	n/a	1.92	2.0	n/a
Fuel flow to engine (without engine driven pump), approx.	m³/h	1.79	1.95	n/a	2.15	1.95	n/a	2.2	1.95	n/a	2.2
HFO viscosity before engine	cSt	16... 24	16... 24	n/a	16... 24	16... 24	n/a	16... 24	16... 24	n/a	16... 24

Wärtsilä 9L20		AE/DE	AE/DE	AE/DE LFO Op- timized	AE/DE HFO Op- timized	ME	ME LFO Op- timized	ME HFO Op- timized	ME	ME LFO Op- timized	ME HFO Op- timized
Cylinder output	kW	185	200	220	220	200	220	220	200	220	220
Engine speed	RPM	900	1000	1200	1200	1000	1200	1200	1000	1200	1200
Speed mode		Constant	Constant	Constant	Constant	Variable	Variable	Variable	Constant	Constant	Constant
Max. HFO temperature before engine (TE101)	°C	140	140	n/a	140	140	n/a	140	140	n/a	140
MDF viscosity, min.	cSt	1.8	1.8	1.8	1.8	1.8	1.8	1.8	1.8	1.8	1.8
Max. MDF temperature before engine (TE101)	°C	45	45	45	45	45	45	45	45	45	45
Fuel consumption at 100% load, HFO	g/kWh	194.4	195.8	n/a	196.8	196.3	n/a	200.7	196.3	n/a	200.7
Fuel consumption at 85% load, HFO	g/kWh	191.2	192.9	n/a	194.4	191.1	n/a	196.0	193.3	n/a	197.3
Fuel consumption at 75% load, HFO	g/kWh	190.8	193.2	n/a	195.2	190.6	n/a	193.4	193.7	n/a	197.9
Fuel consumption at 50% load, HFO	g/kWh	198.3	199.9	n/a	204.1	194.8	n/a	194.1	200.4	n/a	205.6
Fuel consumption at 100% load, MDF	g/kWh	193.4	194.9	194.8	196.7	195.3	198.7	201.4	195.3	198.7	200.6
Fuel consumption at 85% load, MDF	g/kWh	190.4	192.0	193.5	195.0	190.3	193.8	196.0	192.5	196.0	197.4
Fuel consumption at 75% load, MDF	g/kWh	190.1	192.5	194.5	195.6	189.8	191.5	193.4	193.0	196.8	197.9
Fuel consumption at 50% load, MDF	g/kWh	197.8	199.4	203.6	204.1	194.3	191.5	192.5	199.9	204.9	205.3
Clean leak fuel quantity, MDF at 100% load	kg/h	4.86	4.86	4.86	4.86	4.86	4.86	4.86	4.86	4.86	4.86
Lubricating oil system											
Pressure before bearings, nom. (PT201)	kPa	450	450	450	450	450	450	450	450	450	450
Suction ability main pump, including pipe loss, max.	kPa	20	20	20	20	20	20	20	20	20	20
Priming pressure, nom. (PT201)	kPa	80	80	80	80	80	80	80	80	80	80
Suction ability priming pump, including pipe loss, max.	kPa	20	20	20	20	20	20	20	20	20	20
Temperature before bearings, nom. (TE201)	°C	66	66	66	66	66	66	66	66	66	66
Temperature after engine, approx.	°C	78	78	78	78	78	78	78	78	78	78
Pump capacity (main), engine driven	m³/h	43	48	48	48	64	64	64	48	48	48
Priming pump capacity, 50Hz/60Hz	m³/h	8.6 / 10.5	8.6 / 10.5	8.6 / 10.5	8.6 / 10.5	8.6 / 10.5	8.6 / 10.5	8.6 / 10.5	8.6 / 10.5	8.6 / 10.5	8.6 / 10.5
Oil volume, wet sump	m³	0.55	0.55	0.55	0.55	0.71	0.71	0.71	0.71	0.71	0.71
Oil volume in separate system oil tank	m³	2.2	2.4	2.7	2.7	2.4	2.7	2.7	2.4	2.7	2.7
Filter fineness, nom.	microns	25	25	25	25	25	25	25	25	25	25
Oil consumption at 100% load, max.	g/kWh	0.5	0.5	0.35	0.35	0.5	0.35	0.35	0.5	0.35	0.35
Crankcase ventilation flow rate at 100% load	l/min	1170	1170	1170	1170	1170	1170	1170	1170	1170	1170
Crankcase ventilation backpressure, max.	kPa	0.3	0.3	0.3	0.3	0.3	0.3	0.3	0.3	0.3	0.3
Oil volume in speed governor	liters	1.4...2.2	1.4...2.2	1.4...2.2	1.4...2.2	1.4...2.2	1.4...2.2	1.4...2.2	1.4...2.2	1.4...2.2	1.4...2.2
Cooling water system											
High temperature cooling water system											
Pressure at engine, after pump, nom. (PT401)	kPa	200 + static	200 + static	200 + static	200 + static	200 + static	200 + static	200 + static	200 + static	200 + static	200 + static
Pressure at engine, after pump, max. (PT401)	kPa	500	500	500	500	350	350	350	500	500	500

Wärtsilä 9L20		AE/DE	AE/DE	AE/DE LFO Op- timized	AE/DE HFO Op- timized	ME	ME LFO Op- timized	ME HFO Op- timized	ME	ME LFO Op- timized	ME HFO Op- timized
Cylinder output	kW	185	200	220	220	200	220	220	200	220	220
Engine speed	RPM	900	1000	1200	1200	1000	1200	1200	1000	1200	1200
Speed mode		Constant	Constant	Constant	Constant	Variable	Variable	Variable	Constant	Constant	Constant
Temperature before cylinder, approx. (TE401)	°C	83	83	83	83	83	83	83	83	83	83
Temperature after engine, nom.	°C	91	91	91	91	91	91	91	91	91	91
Capacity of engine driven pump, nom.	m ³ /h	44	45	46	46	45	46	46	45	46	46
Pressure drop over engine, total	kPa	90	90	90	90	90	90	90	90	90	90
Pressure drop in external system, max.	kPa	120	120	120	120	120	120	120	120	120	120
Water volume in engine	m ³	0.16	0.16	0.16	0.16	0.16	0.16	0.16	0.16	0.16	0.16
Pressure from expansion tank	kPa	70...150	70...150	70...150	70...150	70...150	70...150	70...150	70...150	70...150	70...150
Low temperature cooling water system											
Pressure at engine, after pump, nom. (PT451)	kPa	200 + static	200 + static	200 + static	200 + static	200 + static	200 + static	200 + static	200 + static	200 + static	200 + static
Pressure at engine, after pump, max. (PT451)	kPa	500	500	500	500	350	350	350	500	500	500
Temperature before engine, min...max	°C	25...38	25...38	25...38	25...38	25...38	25...38	25...38	25...38	25...38	25...38
Capacity of engine driven pump, nom.	m ³ /h	50	54	51	51	54	51	51	54	51	51
Pressure drop over charge air cooler	kPa	30	30	30	30	30	30	30	30	30	30
Pressure drop over oil cooler	kPa	30	30	30	30	30	30	30	30	30	30
Pressure drop in external system, max.	kPa	120	120	120	120	120	120	120	120	120	120
Pressure from expansion tank	kPa	70...150	70...150	70...150	70...150	70...150	70...150	70...150	70...150	70...150	70...150
Starting air system											
Pressure, nom.	kPa	3000	3000	3000	3000	3000	3000	3000	3000	3000	3000
Pressure, max.	kPa	3000	3000	3000	3000	3000	3000	3000	3000	3000	3000
Low pressure limit in air vessels	kPa	1800	1800	1800	1800	1800	1800	1800	1800	1800	1800
Starting air consumption, start (successful)	Nm ³	1.2	1.2	1.2	1.2	1.2	1.2	1.2	1.2	1.2	1.2

Notes:

- Note 1 At ISO 15550 conditions (ambient air temperature 25°C, LT-water 25°C) and 100% load. Flow tolerance 5%.
- Note 2 At ISO 15550 conditions (ambient air temperature 25°C, LT-water 25°C). Flow tolerance 5% and temperature tolerance 15°C.
Also it's possible to have higher than "max" backpressure shown above, please contact Wärtsilä for additional information.
- Note 3 At ISO 15550 conditions (ambient air temperature 25°C, LT-water 25°C) and 100% load. Tolerance for cooling water heat 10%, tolerance for radiation heat 30%. Fouling factors and a margin to be taken into account when dimensioning heat exchangers.
- Note 4 At ambient conditions according to ISO 15550. Lower calorific value 42 700 kJ/kg. With engine driven pumps (two cooling water + one lubricating oil pump). Tolerance 5%.

ME = Engine driving propeller, variable speed

AE = Auxiliary engine driving generator

DE = Diesel-Electric engine driving generator

Subject to revision without notice.

3.5.2 SCR Ready

3.5.2.1 900 & 1000 rpm

Wärtsilä 9L20		AE/DE	AE/DE	ME	ME
Cylinder output	kW	185	200	200	200
Engine speed	RPM	900	1000	1000	1000
Speed mode		Constant	Constant	Variable	Constant
Engine output	kW	1665	1800	1800	1800
Mean effective pressure	MPa	2.8	2.73	2.73	2.73
Combustion air system (Note 1)					
Flow at 100% load	kg/s	3.15	3.41	3.41	3.41
Temperature at turbocharger intake, max.	°C	45	45	45	45
Temperature after air cooler (TE601)	°C	50...70	50...70	50...70	50...70
Exhaust gas system (Note 2)					
Flow at 100% load	kg/s	3.24	3.51	3.51	3.51
Flow at 85% load	kg/s	2.79	3.15	3.06	3.15
Flow at 75% load	kg/s	2.43	2.79	2.7	2.79
Flow at 50% load	kg/s	1.8	1.8	1.8	1.8
Temperature after turbocharger, 100% load (TE517)	°C	363	358	363	358
Temperature after turbocharger, 85% load (TE517)	°C	340	340	340	340
Temperature after turbocharger, 75% load (TE517)	°C	340	340	340	340
Temperature after turbocharger, 50% load (TE517)	°C	348	348	368	348
Backpressure, max.	kPa	5.0	5.0	5.0	5.0
Calculated pipe diameter for 35 m/s	mm	460	476	478	476
Heat balance (Note 3)					
Jacket water, HT-circuit	kW	360	378	378	378
Charge air, LT-circuit	kW	558	612	612	612
Lubricating oil, LT-circuit	kW	252	279	279	279
Radiation	kW	72	72	72	72
Fuel system (Note 4)					
Pressure before injection pumps (PT101)	kPa	700±50	700±50	700±50	700±50
Pressure before engine driven fuel feed pump, min. (MDF only)	kPa	15	15	15	15
Engine driven pump capacity (MDF only)	m³/h	1.73	1.92	1.92	1.92
Fuel flow to engine (without engine driven pump), approx.	m³/h	1.8	1.95	1.95	1.95
HFO viscosity before engine	cSt	16... 24	16... 24	16... 24	16... 24
Max. HFO temperature before engine (TE101)	°C	140	140	140	140

Wärtsilä 9L20		AE/DE	AE/DE	ME	ME
Cylinder output	kW	185	200	200	200
Engine speed	RPM	900	1000	1000	1000
Speed mode		Constant	Constant	Variable	Constant
MDF viscosity, min.	cSt	1.8	1.8	1.8	1.8
Max. MDF temperature before engine (TE101)	°C	45	45	45	45
Fuel consumption at 100% load, HFO	g/kWh	195.6	196.3	196.3	196.3
Fuel consumption at 85% load, HFO	g/kWh	194.3	195.9	193.1	195.9
Fuel consumption at 75% load, HFO	g/kWh	193.0	195.8	192.5	195.8
Fuel consumption at 50% load, HFO	g/kWh	198.3	199.9	194.8	200.4
Fuel consumption at 100% load, MDF	g/kWh	194.7	195.3	195.3	195.3
Fuel consumption at 85% load, MDF	g/kWh	193.4	195.0	192.3	195.0
Fuel consumption at 75% load, MDF	g/kWh	192.3	195.0	191.7	195.0
Fuel consumption at 50% load, MDF	g/kWh	197.8	199.4	194.3	199.9
Clean leak fuel quantity, MDF at 100% load	kg/h	4.86	4.86	4.86	4.86
Lubricating oil system					
Pressure before bearings, nom. (PT201)	kPa	450	450	450	450
Suction ability main pump, including pipe loss, max.	kPa	20	20	20	20
Priming pressure, nom. (PT201)	kPa	80	80	80	80
Suction ability priming pump, including pipe loss, max.	kPa	20	20	20	20
Temperature before bearings, nom. (TE201)	°C	66	66	66	66
Temperature after engine, approx.	°C	78	78	78	78
Pump capacity (main), engine driven	m³/h	43	48	64	48
Priming pump capacity, 50Hz/60Hz	m³/h	8.6 / 10.5	8.6 / 10.5	8.6 / 10.5	8.6 / 10.5
Oil volume, wet sump	m³	0.55	0.55	0.71	0.71
Oil volume in separate system oil tank	m³	2.2	2.4	2.4	2.4
Filter fineness, nom.	mi-crons	25	25	25	25
Oil consumption at 100% load, max.	g/kWh	0.5	0.5	0.5	0.5
Crankcase ventilation flow rate at 100% load	l/min	1170	1170	1170	1170
Crankcase ventilation backpressure, max.	kPa	0.3	0.3	0.3	0.3
Oil volume in speed governor	liters	1.4...2.2	1.4...2.2	1.4...2.2	1.4...2.2
Cooling water system					
High temperature cooling water system					
Pressure at engine, after pump, nom. (PT401)	kPa	200 + static	200 + static	200 + static	200 + static
Pressure at engine, after pump, max. (PT401)	kPa	500	500	350	500
Temperature before cylinder, approx. (TE401)	°C	83	83	83	83
Temperature after engine, nom.	°C	91	91	91	91
Capacity of engine driven pump, nom.	m³/h	44	45	45	45

Wärtsilä 9L20		AE/DE	AE/DE	ME	ME
Cylinder output	kW	185	200	200	200
Engine speed	RPM	900	1000	1000	1000
Speed mode		Constant	Constant	Variable	Constant
Pressure drop over engine, total	kPa	90	90	90	90
Pressure drop in external system, max.	kPa	120	120	120	120
Water volume in engine	m ³	0.16	0.16	0.16	0.16
Pressure from expansion tank	kPa	70...150	70...150	70...150	70...150
Low temperature cooling water system					
Pressure at engine, after pump, nom. (PT451)	kPa	200 + static	200 + static	200 + static	200 + static
Pressure at engine, after pump, max. (PT451)	kPa	500	500	350	500
Temperature before engine, min...max	°C	25...38	25...38	25...38	25...38
Capacity of engine driven pump, nom.	m ³ /h	50	54	54	54
Pressure drop over charge air cooler	kPa	30	30	30	30
Pressure drop over oil cooler	kPa	30	30	30	30
Pressure drop in external system, max.	kPa	120	120	120	120
Pressure from expansion tank	kPa	70...150	70...150	70...150	70...150
Starting air system					
Pressure, nom.	kPa	3000	3000	3000	3000
Pressure, max.	kPa	3000	3000	3000	3000
Low pressure limit in air vessels	kPa	1800	1800	1800	1800
Starting air consumption, start (successful)	Nm ³	1.2	1.2	1.2	1.2

Notes:

- Note 1 At ISO 15550 conditions (ambient air temperature 25°C, LT-water 25°C) and 100% load. Flow tolerance 5%.
- Note 2 At ISO 15550 conditions (ambient air temperature 25°C, LT-water 25°C). Flow tolerance 5% and temperature tolerance 15°C.
Also it's possible to have higher than "max" backpressure shown above, please contact Wärtsilä for additional information.
- Note 3 At ISO 15550 conditions (ambient air temperature 25°C, LT-water 25°C) and 100% load. Tolerance for cooling water heat 10%, tolerance for radiation heat 30%. Fouling factors and a margin to be taken into account when dimensioning heat exchangers.
- Note 4 At ambient conditions according to ISO 15550. Lower calorific value 42 700 kJ/kg. With engine driven pumps (two cooling water + one lubricating oil pump). Tolerance 5%.

ME = Engine driving propeller, variable speed

AE = Auxiliary engine driving generator

DE = Diesel-Electric engine driving generator

Subject to revision without notice.

3.5.2.2 1200 rpm fuel sulphur content $\leq 0,5\%$

Wärtsilä 9L20		AE/DE LFO Optimized	ME LFO Optimized	ME LFO Optimized	AE/DE HFO Optimized	ME HFO Optimized	ME HFO Optimized
Cylinder output	kW	220	220	220	220	220	220
Engine speed	RPM	1200	1200	1200	1200	1200	1200
Speed mode		Constant	Variable	Constant	Constant	Variable	Constant
Engine output	kW	1980	1980	1980	1980	1980	1980
Mean effective pressure	MPa	2.5	2.5	2.5	2.5	2.5	2.5
Combustion air system (Note 1)							
Flow at 100% load	kg/s	4.03	4.21	4.03	4.03	4.21	4.03
Temperature at turbocharger intake, max.	°C	45	45	45	45	45	45
Temperature after air cooler (TE601)	°C	50...70	50...70	50...70	50...70	50...70	50...70
Exhaust gas system (Note 2)							
Flow at 100% load	kg/s	4.14	4.32	4.14	4.14	4.32	4.14
Flow at 85% load	kg/s	3.51	3.51	3.51	3.51	3.51	3.51
Flow at 75% load	kg/s	3.15	3.06	3.15	3.15	3.06	3.15
Flow at 50% load	kg/s	2.25	2.07	2.25	2.25	2.07	2.25
Temperature after turbocharger, 100% load (TE517)	°C	320	320	320	320	320	320
Temperature after turbocharger, 85% load (TE517)	°C	320	320	320	320	320	320
Temperature after turbocharger, 75% load (TE517)	°C	320	329	320	320	329	320
Temperature after turbocharger, 50% load (TE517)	°C	337	333	337	337	333	337
Backpressure, max.	kPa	5.0	5.0	5.0	5.0	5.0	5.0
Calculated pipe diameter for 35 m/s	mm	502	512	502	502	512	502
Heat balance (Note 3)							
Jacket water, HT-circuit	kW	450	441	450	450	441	450
Charge air, LT-circuit	kW	702	792	702	702	792	702
Lubricating oil, LT-circuit	kW	234	243	234	234	243	234
Radiation	kW	71	71	71	71	71	71
Fuel system (Note 4)							
Pressure before injection pumps (PT101)	kPa	700±50	700±50	700±50	700±50	700±50	700±50
Pressure before engine driven fuel feed pump, min. (MDF only)	kPa	15	15	15	15	15	15
Engine driven pump capacity (MDF only)	m³/h	2.0	2.0	2.0	n/a	n/a	n/a
Fuel flow to engine (without engine driven pump), approx.	m³/h	n/a	n/a	n/a	2.16	2.2	2.2
HFO viscosity before engine	cSt	n/a	n/a	n/a	16... 24	16... 24	16... 24
Max. HFO temperature before engine (TE101)	°C	n/a	n/a	n/a	140	140	140
MDF viscosity, min.	cSt	1.8	1.8	1.8	1.8	1.8	1.8

Wärtsilä 9L20		AE/DE LFO Optimized	ME LFO Optimized	ME LFO Optimized	AE/DE HFO Optimized	ME HFO Optimized	ME HFO Optimized
Cylinder output	kW	220	220	220	220	220	220
Engine speed	RPM	1200	1200	1200	1200	1200	1200
Speed mode		Constant	Variable	Constant	Constant	Variable	Constant
Max. MDF temperature before engine (TE101)	°C	45	45	45	45	45	45
Fuel consumption at 100% load, HFO	g/kWh	n/a	n/a	n/a	197.1	200.7	200.7
Fuel consumption at 85% load, HFO	g/kWh	n/a	n/a	n/a	196.1	196.2	199.0
Fuel consumption at 75% load, HFO	g/kWh	n/a	n/a	n/a	197.0	193.4	199.6
Fuel consumption at 50% load, HFO	g/kWh	n/a	n/a	n/a	204.1	194.1	205.6
Fuel consumption at 100% load, MDF	g/kWh	195.1	198.7	198.7	197.0	201.4	200.9
Fuel consumption at 85% load, MDF	g/kWh	195.2	194.0	197.7	196.8	196.2	199.2
Fuel consumption at 75% load, MDF	g/kWh	196.2	191.5	198.5	197.3	193.4	199.6
Fuel consumption at 50% load, MDF	g/kWh	203.6	191.5	204.9	204.1	192.5	205.3
Clean leak fuel quantity, MDF at 100% load	kg/h	4.86	4.86	4.86	4.86	4.86	4.86
Lubricating oil system							
Pressure before bearings, nom. (PT201)	kPa	450	450	450	450	450	450
Suction ability main pump, including pipe loss, max.	kPa	20	20	20	20	20	20
Priming pressure, nom. (PT201)	kPa	80	80	80	80	80	80
Suction ability priming pump, including pipe loss, max.	kPa	20	20	20	20	20	20
Temperature before bearings, nom. (TE201)	°C	66	66	66	66	66	66
Temperature after engine, approx.	°C	78	78	78	78	78	78
Pump capacity (main), engine driven	m³/h	48	64	48	48	64	48
Priming pump capacity, 50Hz/60Hz	m³/h	8.6 / 10.5	8.6 / 10.5	8.6 / 10.5	8.6 / 10.5	8.6 / 10.5	8.6 / 10.5
Oil volume, wet sump	m³	0.55	0.71	0.71	0.55	0.71	0.71
Oil volume in separate system oil tank	m³	2.7	2.7	2.7	2.7	2.7	2.7
Filter fineness, nom.	microns	25	25	25	25	25	25
Oil consumption at 100% load, max.	g/kWh	0.35	0.35	0.35	0.35	0.35	0.35
Crankcase ventilation flow rate at 100% load	l/min	1170	1170	1170	1170	1170	1170
Crankcase ventilation backpressure, max.	kPa	0.3	0.3	0.3	0.3	0.3	0.3
Oil volume in speed governor	liters	1.4...2.2	1.4...2.2	1.4...2.2	1.4...2.2	1.4...2.2	1.4...2.2
Cooling water system							
High temperature cooling water system							
Pressure at engine, after pump, nom. (PT401)	kPa	200 + static	200 + static	200 + static	200 + static	200 + static	200 + static
Pressure at engine, after pump, max. (PT401)	kPa	500	350	500	500	350	500
Temperature before cylinder, approx. (TE401)	°C	83	83	83	83	83	83
Temperature after engine, nom.	°C	91	91	91	91	91	91

Wärtsilä 9L20		AE/DE LFO Op- timized	ME LFO Op- timized	ME LFO Op- timized	AE/DE HFO Op- timized	ME HFO Op- timized	ME HFO Op- timized
Cylinder output	kW	220	220	220	220	220	220
Engine speed	RPM	1200	1200	1200	1200	1200	1200
Speed mode		Constant	Variable	Constant	Constant	Variable	Constant
Capacity of engine driven pump, nom.	m ³ /h	46	46	46	46	46	46
Pressure drop over engine, total	kPa	90	90	90	90	90	90
Pressure drop in external system, max.	kPa	120	120	120	120	120	120
Water volume in engine	m ³	0.16	0.16	0.16	0.16	0.16	0.16
Pressure from expansion tank	kPa	70...150	70...150	70...150	70...150	70...150	70...150
Low temperature cooling water system							
Pressure at engine, after pump, nom. (PT451)	kPa	200 + static	200 + static	200 + static	200 + static	200 + static	200 + static
Pressure at engine, after pump, max. (PT451)	kPa	500	350	500	500	350	500
Temperature before engine, min...max	°C	25...38	25...38	25...38	25...38	25...38	25...38
Capacity of engine driven pump, nom.	m ³ /h	51	51	51	51	51	51
Pressure drop over charge air cooler	kPa	30	30	30	30	30	30
Pressure drop over oil cooler	kPa	30	30	30	30	30	30
Pressure drop in external system, max.	kPa	120	120	120	120	120	120
Pressure from expansion tank	kPa	70...150	70...150	70...150	70...150	70...150	70...150
Starting air system							
Pressure, nom.	kPa	3000	3000	3000	3000	3000	3000
Pressure, max.	kPa	3000	3000	3000	3000	3000	3000
Low pressure limit in air vessels	kPa	1800	1800	1800	1800	1800	1800
Starting air consumption, start (successful)	Nm ³	1.2	1.2	1.2	1.2	1.2	1.2

Notes:

- Note 1 At ISO 15550 conditions (ambient air temperature 25°C, LT-water 25°C) and 100% load. Flow tolerance 5%.
- Note 2 At ISO 15550 conditions (ambient air temperature 25°C, LT-water 25°C). Flow tolerance 5% and temperature tolerance 15°C.
Also it's possible to have higher than "max" backpressure shown above, please contact Wärtsilä for additional information.
- Note 3 At ISO 15550 conditions (ambient air temperature 25°C, LT-water 25°C) and 100% load. Tolerance for cooling water heat 10%, tolerance for radiation heat 30%. Fouling factors and a margin to be taken into account when dimensioning heat exchangers.
- Note 4 At ambient conditions according to ISO 15550. Lower calorific value 42 700 kJ/kg. With engine driven pumps (two cooling water + one lubricating oil pump). Tolerance 5%.

ME = Engine driving propeller, variable speed

AE = Auxiliary engine driving generator

DE = Diesel-Electric engine driving generator

Subject to revision without notice.

3.5.2.3 1200 rpm fuel sulphur content > 0,5%

Wärtsilä 9L20		AE/DE LFO Optimized	ME LFO Optimized	ME LFO Optimized	AE/DE HFO Optimized	ME HFO Optimized	ME HFO Optimized
Cylinder output	kW	220	220	220	220	220	220
Engine speed	RPM	1200	1200	1200	1200	1200	1200
Speed mode		Constant	Variable	Constant	Constant	Variable	Constant
Engine output	kW	1980	1980	1980	1980	1980	1980
Mean effective pressure	MPa	2.5	2.5	2.5	2.5	2.5	2.5
Combustion air system (Note 1)							
Flow at 100% load	kg/s	3.76	3.93	3.75	3.76	3.93	3.75
Temperature at turbocharger intake, max.	°C	45	45	45	45	45	45
Temperature after air cooler (TE601)	°C	50...70	50...70	50...70	50...70	50...70	50...70
Exhaust gas system (Note 2)							
Flow at 100% load	kg/s	3.87	4.05	3.87	3.87	4.05	3.87
Flow at 85% load	kg/s	3.33	3.42	3.33	3.33	3.42	3.33
Flow at 75% load	kg/s	2.97	2.97	2.97	2.97	2.97	2.97
Flow at 50% load	kg/s	2.16	2.07	2.16	2.16	2.07	2.16
Temperature after turbocharger, 100% load (TE517)	°C	340	340	340	340	340	340
Temperature after turbocharger, 85% load (TE517)	°C	340	340	340	340	340	340
Temperature after turbocharger, 75% load (TE517)	°C	340	340	340	340	340	340
Temperature after turbocharger, 50% load (TE517)	°C	340	340	340	340	340	340
Backpressure, max.	kPa	5.0	5.0	5.0	5.0	5.0	5.0
Calculated pipe diameter for 35 m/s	mm	493	504	493	493	504	493
Heat balance (Note 3)							
Jacket water, HT-circuit	kW	486	477	486	486	477	486
Charge air, LT-circuit	kW	702	792	702	702	792	702
Lubricating oil, LT-circuit	kW	243	252	243	243	252	243
Radiation	kW	73	73	73	73	73	73
Fuel system (Note 4)							
Pressure before injection pumps (PT101)	kPa	700±50	700±50	700±50	700±50	700±50	700±50
Pressure before engine driven fuel feed pump, min. (MDF only)	kPa	15	15	15	15	15	15
Engine driven pump capacity (MDF only)	m³/h	2.0	2.0	2.0	n/a	n/a	n/a
Fuel flow to engine (without engine driven pump), approx.	m³/h	n/a	n/a	n/a	2.19	2.22	2.22
HFO viscosity before engine	cSt	n/a	n/a	n/a	16... 24	16... 24	16... 24
Max. HFO temperature before engine (TE101)	°C	n/a	n/a	n/a	140	140	140
MDF viscosity, min.	cSt	1.8	1.8	1.8	1.8	1.8	1.8

Wärtsilä 9L20		AE/DE LFO Op- timized	ME LFO Op- timized	ME LFO Op- timized	AE/DE HFO Op- timized	ME HFO Op- timized	ME HFO Op- timized
Cylinder output	kW	220	220	220	220	220	220
Engine speed	RPM	1200	1200	1200	1200	1200	1200
Speed mode		Constant	Variable	Constant	Constant	Variable	Constant
Max. MDF temperature before engine (TE101)	°C	45	45	45	45	45	45
Fuel consumption at 100% load, HFO	g/kWh	n/a	n/a	n/a	200.1	203.0	203.0
Fuel consumption at 85% load, HFO	g/kWh	n/a	n/a	n/a	198.7	197.6	199.9
Fuel consumption at 75% load, HFO	g/kWh	n/a	n/a	n/a	199.2	195.3	200.4
Fuel consumption at 50% load, HFO	g/kWh	n/a	n/a	n/a	206.3	195.6	207.0
Fuel consumption at 100% load, MDF	g/kWh	198.1	201.0	201.0	200.0	203.7	202.9
Fuel consumption at 85% load, MDF	g/kWh	197.8	195.9	198.6	199.2	198.1	200.0
Fuel consumption at 75% load, MDF	g/kWh	198.5	192.6	199.2	199.6	194.5	200.4
Fuel consumption at 50% load, MDF	g/kWh	205.8	192.1	206.2	206.3	193.0	206.7
Clean leak fuel quantity, MDF at 100% load	kg/h	4.86	4.86	4.86	4.86	4.86	4.86
Lubricating oil system							
Pressure before bearings, nom. (PT201)	kPa	450	450	450	450	450	450
Suction ability main pump, including pipe loss, max.	kPa	20	20	20	20	20	20
Priming pressure, nom. (PT201)	kPa	80	80	80	80	80	80
Suction ability priming pump, including pipe loss, max.	kPa	20	20	20	20	20	20
Temperature before bearings, nom. (TE201)	°C	66	66	66	66	66	66
Temperature after engine, approx.	°C	78	78	78	78	78	78
Pump capacity (main), engine driven	m ³ /h	48	64	48	48	64	48
Priming pump capacity, 50Hz/60Hz	m ³ /h	8.6 / 10.5	8.6 / 10.5	8.6 / 10.5	8.6 / 10.5	8.6 / 10.5	8.6 / 10.5
Oil volume, wet sump	m ³	0.55	0.71	0.71	0.55	0.71	0.71
Oil volume in separate system oil tank	m ³	2.7	2.7	2.7	2.7	2.7	2.7
Filter fineness, nom.	mi- crons	25	25	25	25	25	25
Oil consumption at 100% load, max.	g/kWh	0.35	0.35	0.35	0.35	0.35	0.35
Crankcase ventilation flow rate at 100% load	l/min	1170	1170	1170	1170	1170	1170
Crankcase ventilation backpressure, max.	kPa	0.3	0.3	0.3	0.3	0.3	0.3
Oil volume in speed governor	liters	1.4...2.2	1.4...2.2	1.4...2.2	1.4...2.2	1.4...2.2	1.4...2.2
Cooling water system							
High temperature cooling water system							
Pressure at engine, after pump, nom. (PT401)	kPa	200 + static	200 + static	200 + static	200 + static	200 + static	200 + static
Pressure at engine, after pump, max. (PT401)	kPa	500	350	500	500	350	500
Temperature before cylinder, approx. (TE401)	°C	83	83	83	83	83	83
Temperature after engine, nom.	°C	91	91	91	91	91	91

Wärtsilä 9L20		AE/DE LFO Optimized	ME LFO Optimized	ME LFO Optimized	AE/DE HFO Optimized	ME HFO Optimized	ME HFO Optimized
Cylinder output	kW	220	220	220	220	220	220
Engine speed	RPM	1200	1200	1200	1200	1200	1200
Speed mode		Constant	Variable	Constant	Constant	Variable	Constant
Capacity of engine driven pump, nom.	m ³ /h	46	46	46	46	46	46
Pressure drop over engine, total	kPa	90	90	90	90	90	90
Pressure drop in external system, max.	kPa	120	120	120	120	120	120
Water volume in engine	m ³	0.16	0.16	0.16	0.16	0.16	0.16
Pressure from expansion tank	kPa	70...150	70...150	70...150	70...150	70...150	70...150
Low temperature cooling water system							
Pressure at engine, after pump, nom. (PT451)	kPa	200 + static	200 + static	200 + static	200 + static	200 + static	200 + static
Pressure at engine, after pump, max. (PT451)	kPa	500	350	500	500	350	500
Temperature before engine, min...max	°C	25...38	25...38	25...38	25...38	25...38	25...38
Capacity of engine driven pump, nom.	m ³ /h	51	51	51	51	51	51
Pressure drop over charge air cooler	kPa	30	30	30	30	30	30
Pressure drop over oil cooler	kPa	30	30	30	30	30	30
Pressure drop in external system, max.	kPa	120	120	120	120	120	120
Pressure from expansion tank	kPa	70...150	70...150	70...150	70...150	70...150	70...150
Starting air system							
Pressure, nom.	kPa	3000	3000	3000	3000	3000	3000
Pressure, max.	kPa	3000	3000	3000	3000	3000	3000
Low pressure limit in air vessels	kPa	1800	1800	1800	1800	1800	1800
Starting air consumption, start (successful)	Nm ³	1.2	1.2	1.2	1.2	1.2	1.2

Notes:

- Note 1 At ISO 15550 conditions (ambient air temperature 25°C, LT-water 25°C) and 100% load. Flow tolerance 5%.
- Note 2 At ISO 15550 conditions (ambient air temperature 25°C, LT-water 25°C). Flow tolerance 5% and temperature tolerance 15°C.
Also it's possible to have higher than "max" backpressure shown above, please contact Wärtsilä for additional information.
- Note 3 At ISO 15550 conditions (ambient air temperature 25°C, LT-water 25°C) and 100% load. Tolerance for cooling water heat 10%, tolerance for radiation heat 30%. Fouling factors and a margin to be taken into account when dimensioning heat exchangers.
- Note 4 At ambient conditions according to ISO 15550. Lower calorific value 42 700 kJ/kg. With engine driven pumps (two cooling water + one lubricating oil pump). Tolerance 5%.

ME = Engine driving propeller, variable speed

AE = Auxiliary engine driving generator

DE = Diesel-Electric engine driving generator

Subject to revision without notice.

NOTE

Fuel consumptions in SCR operation guaranteed only when using Wärtsilä SCR unit.

NOTE

For proper operation of the Wärtsilä Nitrogen Oxide Reducer (NOR) systems, the exhaust temperature after the engine needs to be kept within a certain temperature window. Minimum target temperature are 320°C or 340°C (with liquid fuel) depending of sulphur content. Please consult your sales contact at Wärtsilä for more information about SCR Operation.

NOTE

Real-time product information including all technical data covered in this chapter will be available through Wärtsilä's website (an online tool called Engine Online Configurators) in late 2019. Please check online for the most updated technical data when they are available.

4. Description of the Engine

4.1 Definitions

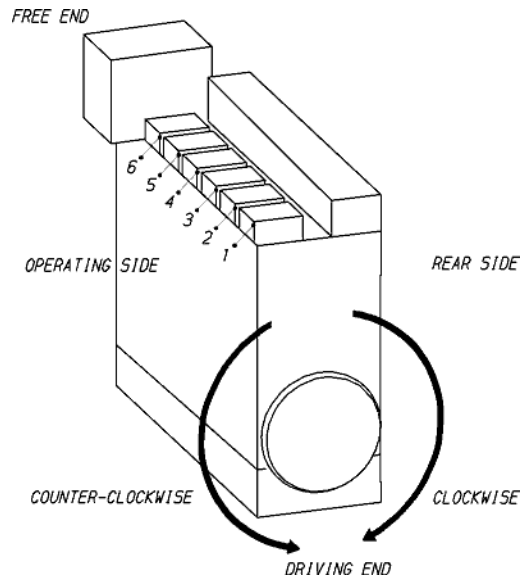

Fig 4-1 In-line engine definitions (1V93C0029)

4.2 Main components and systems

4.2.1 Engine block

The engine block is a one piece nodular cast iron component with integrated channels for lubricating oil and cooling water.

The main bearing caps are fixed from below by two hydraulically tensioned screws. They are guided sideways by the engine block at the top as well as at the bottom. Hydraulically tightened horizontal side screws at the lower guiding provide a very rigid crankshaft bearing.

4.2.2 Crankshaft

The crankshaft is forged in one piece and mounted on the engine block in an under-slung way.

4.2.3 Connecting rod

The connecting rod is of forged alloy steel. All connecting rod studs are hydraulically tightened. Oil is led to the gudgeon pin bearing and piston through a bore in the connecting rod.

4.2.4 Main bearings and big end bearings

The main bearings and the big end bearings are of the Al based bi-metal type with steel back.

4.2.5 Cylinder liner

The cylinder liners are centrifugally cast of a special grey cast iron alloy developed for good wear resistance and high strength. They are of wet type, sealed against the engine block metallically at the upper part and by O-rings at the lower part. To eliminate the risk of bore polishing the liner is equipped with an anti-polishing ring.

4.2.6 Piston

The piston is of composite design with nodular cast iron skirt and steel crown. The piston skirt is pressure lubricated, which ensures a well-controlled oil flow to the cylinder liner during all operating conditions. Oil is fed through the connecting rod to the cooling spaces of the piston. The piston cooling operates according to the cocktail shaker principle. The piston ring grooves in the piston top are hardened for better wear resistance.

4.2.7 Piston rings

The piston ring set consists of two directional compression rings and one spring-loaded conformable oil scraper ring. All rings are chromium-plated and located in the piston crown.

4.2.8 Cylinder head

The cylinder head is made of grey cast iron. The thermally loaded flame plate is cooled efficiently by cooling water led from the periphery radially towards the centre of the head. The bridges between the valves cooling channels are drilled to provide the best possible heat transfer.

The mechanical load is absorbed by a strong intermediate deck, which together with the upper deck and the side walls form a box section in the four corners of which the hydraulically tightened cylinder head bolts are situated. The exhaust valve seats are directly water-cooled.

All valves are equipped with valve rotators.

4.2.9 Camshaft and valve mechanism

There is one cam piece for each cylinder with separate bearing in between. The drop forged completely hardened camshaft pieces have fixed cams. The camshaft bearing housings are integrated in the engine block casting and are thus completely closed. The camshaft covers, one for each cylinder, seal against the engine block with a closed O-ring profile.

The valve tappets are of piston type with self-adjustment of roller against cam to give an even distribution of the contact pressure. The valve springs ensure that the valve mechanism is dynamically stable.

Variable Inlet valve Closure (VIC), which is available on IMO Tier 2 engines, offers flexibility to apply early inlet valve closure at high load for lowest NO_x levels, while good part-load performance is ensured by adjusting the advance to zero at low load.

4.2.10 Camshaft drive

The camshafts are driven by the crankshaft through a gear train.

4.2.11 Fuel injection equipment

The injection pumps are one-cylinder pumps located in the “hot-box”, which has the following functions:

- Housing for the injection pump element
- Fuel supply channel along the whole engine
- Fuel return channel from each injection pump
- Lubricating oil supply to the valve mechanism
- Guiding for the valve tappets

The injection pumps have built-in roller tappets and are through-flow type to enable heavy fuel operation. They are also equipped with a stop cylinder, which is connected to the electro-pneumatic overspeed protection system.

The injection valve is centrally located in the cylinder head and the fuel is admitted sideways through a high pressure connection screwed in the nozzle holder. The injection pipe between

the injection pump and the high pressure connection is well protected inside the hot box. The high pressure side of the injection system is completely separated from the hot parts of the exhaust gas components.

4.2.12 Turbocharging and charge air cooling

The selected turbo charger offers the ideal combination of high-pressure ratios and good efficiency.

The charge air cooler is single stage type and cooled by LT-water.

4.2.13 Charge air waste gate

The charge air wastegate is used to reduce the charge air pressure by bleeding air from the charge air system.

4.2.14 Exhaust pipes

The complete exhaust gas system is enclosed in an insulated box consisting of easily removable panels. Mineral wool is used as insulating material.

4.3 Cross sections of the engine

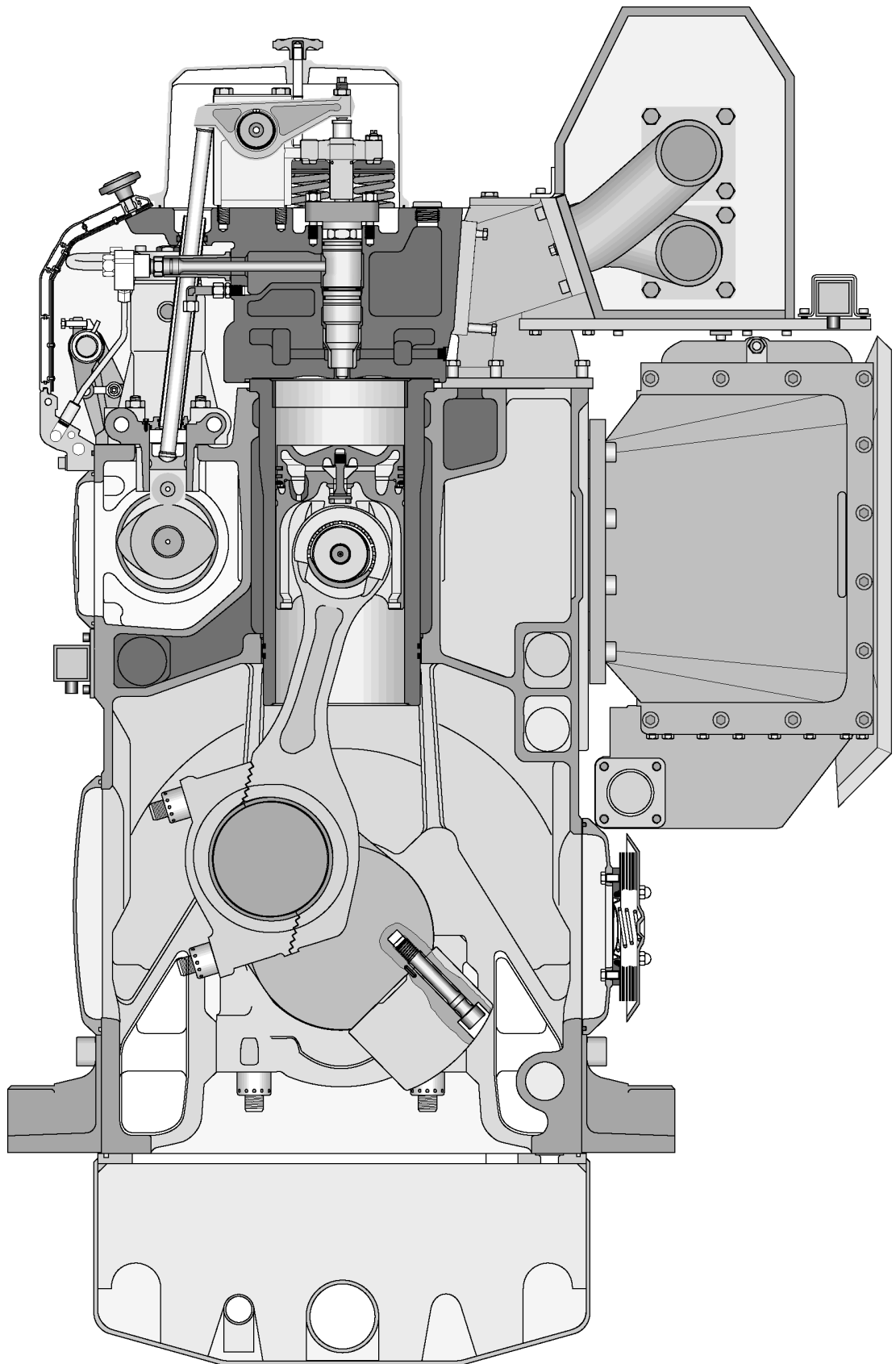

Fig 4-2 Cross sections of the engine

4.4 Expected Technical Life Time

NOTE



- Service actions are combined to certain overhaul packages and intervals. Overhaul intervals are typically based on components, which has shortest technical lifetime. Certain components are also such a type that they need to be replaced every time, when they are removed from the engine. For these reasons components recommended overhaul times can be shorter than technical life time, which is maximum expected lifetime of the component.
- Time Between Overhaul data can be found in Services Engine Operation and Maintenance Manual (O&MM)
- Achieved life times very much depend on the operating conditions, average loading of the engine, fuel quality used, fuel handling systems, performance of maintenance etc. I.e. values given in optimal conditions where Wärtsilä's all recommendations are followed.

Component	Expected Technical Life Times (h)		
	MDF	HFO1 ¹⁾	HFO2 ¹⁾
Piston crown	60000	48000	42000
Piston rings	20000	14000	10000
Cylinder liner	80000	60000	48000
Cylinder head	60000	56000	50000
Inlet valve and valve seat insert	40000	42000	30000
Exhaust valve and valve seat insert	40000	28000 ²⁾	20000
Injection valve nozzle	4000	4000	4000
Injection pump element	28000	28000	20000
Main bearing	60000	48000	42000
Big end bearing	20000	20000	20000

4.4.1 Time between inspection or overhaul

Component	Time between inspection or overhaul (h)		
	MDF	HFO1 ¹⁾	HFO2 ¹⁾
Piston crown	20000	14000	10000
Piston rings	20000	14000	10000
Cylinder liner	20000	14000	10000
Cylinder head	20000	14000	10000
Inlet valve and valve seat insert	20000	14000	10000
Exhaust valve and valve seat insert	20000	14000	10000

Component	Time between inspection or overhaul (h)		
	MDF	HFO1 ¹⁾	HFO2 ¹⁾
Injection valve nozzle	4000	4000	4000
Injection pump element	20000	14000	10000
Main bearing	20000	14000	10000
Big end bearing	20000	14000	10000

NOTE

1) For detailed information of HFO1 and HFO2 qualities, please see chapter [Heavy Fuel Oil \(HFO\)](#).

NOTE

Turbocharger lifetime for W20 Dredger applications are 25000 hours for Constant Speed engines and 50000 hours for Constant Torque engines.

4.5 Engine storage

At delivery the engine is provided with VCI coating and a tarpaulin. For storage longer than 3 months please contact Wärtsilä Finland Oy.

This page intentionally left blank

5. Piping Design, Treatment and Installation

This chapter provides general guidelines for the design, construction and planning of piping systems, however, not excluding other solutions of at least equal standard. Installation related instructions are included in the project specific instructions delivered for each installation.

Fuel, lubricating oil, fresh water and compressed air piping is usually made in seamless carbon steel (DIN 2448) and seamless precision tubes in carbon or stainless steel (DIN 2391), exhaust gas piping in welded pipes of corten or carbon steel (DIN 2458). Sea-water piping should be in Cunifer or hot dip galvanized steel.

NOTE



The pipes in the freshwater side of the cooling water system must not be galvanized!

Attention must be paid to fire risk aspects. Fuel supply and return lines shall be designed so that they can be fitted without tension. Flexible hoses must have an approval from the classification society. If flexible hoses are used in the compressed air system, a purge valve shall be fitted in front of the hose(s).

It is recommended to make a fitting order plan prior to construction.

The following aspects shall be taken into consideration:

- Pockets shall be avoided. When not possible, drain plugs and air vents shall be installed
- Leak fuel drain pipes shall have continuous slope
- Vent pipes shall be continuously rising
- Flanged connections shall be used, cutting ring joints for precision tubes

Maintenance access and dismantling space of valves, coolers and other devices shall be taken into consideration. Flange connections and other joints shall be located so that dismantling of the equipment can be made with reasonable effort.

5.1 Pipe dimensions

When selecting the pipe dimensions, take into account:

- The pipe material and its resistance to corrosion/erosion.
- Allowed pressure loss in the circuit vs delivery head of the pump.
- Required net positive suction head (NPSH) for pumps (suction lines).
- In small pipe sizes the max acceptable velocity is usually somewhat lower than in large pipes of equal length.
- The flow velocity should not be below 1 m/s in sea water piping due to increased risk of fouling and pitting.
- In open circuits the velocity in the suction pipe is typically about 2/3 of the velocity in the delivery pipe.

Table 5-1 Recommended maximum velocities on pump delivery side for guidance

Piping	Pipe material	Max velocity [m/s]
Fuel oil piping (MDF and HFO)	Black steel	1.0
Lubricating oil piping	Black steel	1.5
Fresh water piping	Black steel	2.5
Sea water piping	Galvanized steel	2.5
	Aluminum brass	2.5
	10/90 copper-nickel-iron	3.0
	70/30 copper-nickel	4.5
	Rubber lined pipes	4.5

NOTE

The diameter of gas fuel piping depends only on the allowed pressure loss in the piping, which has to be calculated project specifically.

Compressed air pipe sizing has to be calculated project specifically. The pipe sizes may be chosen on the basis of air velocity or pressure drop. In each pipeline case it is advised to check the pipe sizes using both methods, this to ensure that the alternative limits are not being exceeded.

Pipeline sizing on air velocity: For dry air, practical experience shows that reasonable velocities are 25...30 m/s, but these should be regarded as the maximum above which noise and erosion will take place, particularly if air is not dry. Even these velocities can be high in terms of their effect on pressure drop. In longer supply lines, it is often necessary to restrict velocities to 15 m/s to limit the pressure drop.

Pipeline sizing on pressure drop: As a rule of thumb the pressure drop from the starting air vessel to the inlet of the engine should be max. 0.1 MPa (1 bar) when the bottle pressure is 3 MPa (30 bar).

It is essential that the instrument air pressure, feeding to some critical control instrumentation, is not allowed to fall below the nominal pressure stated in chapter "*Compressed air system*" due to pressure drop in the pipeline.

5.2 Trace heating

The following pipes shall be equipped with trace heating (steam, thermal oil or electrical). It shall be possible to shut off the trace heating.

- All heavy fuel pipes
- All leak fuel and filter flushing pipes carrying heavy fuel

5.3 Pressure class

The pressure class of the piping should be higher than or equal to the design pressure, which should be higher than or equal to the highest operating (working) pressure. The highest operating (working) pressure is equal to the setting of the safety valve in a system.

The pressure in the system can:

- Originate from a positive displacement pump

- Be a combination of the static pressure and the pressure on the highest point of the pump curve for a centrifugal pump
- Rise in an isolated system if the liquid is heated

Within this publication there are tables attached to drawings, which specify pressure classes of connections. The pressure class of a connection can be higher than the pressure class required for the pipe.

Example 1:

The fuel pressure before the engine should be 0.7 MPa (7 bar). The safety filter in dirty condition may cause a pressure loss of 0.1 MPa (1.0 bar). The viscosimeter, automatic filter, preheater and piping may cause a pressure loss of 0.25 MPa (2.5 bar). Consequently the discharge pressure of the circulating pumps may rise to 1.05 MPa (10.5 bar), and the safety valve of the pump shall thus be adjusted e.g. to 1.2 MPa (12 bar).

- A design pressure of not less than 1.2 MPa (12 bar) has to be selected.
- The nearest pipe class to be selected is PN16.
- Piping test pressure is normally 1.5 x the design pressure = 1.8 MPa (18 bar).

Example 2:

The pressure on the suction side of the cooling water pump is 0.1 MPa (1 bar). The delivery head of the pump is 0.3 MPa (3 bar), leading to a discharge pressure of 0.4 MPa (4 bar). The highest point of the pump curve (at or near zero flow) is 0.1 MPa (1 bar) higher than the nominal point, and consequently the discharge pressure may rise to 0.5 MPa (5 bar) (with closed or throttled valves).

- Consequently a design pressure of not less than 0.5 MPa (5 bar) shall be selected.
- The nearest pipe class to be selected is PN6.
- Piping test pressure is normally 1.5 x the design pressure = 0.75 MPa (7.5 bar).

Standard pressure classes are PN4, PN6, PN10, PN16, PN25, PN40, etc.

5.4 Pipe class

Classification societies categorize piping systems in different classes (DNV) or groups (ABS) depending on pressure, temperature and media. The pipe class can determine:

- Type of connections to be used
- Heat treatment
- Welding procedure
- Test method

Systems with high design pressures and temperatures and hazardous media belong to class I (or group I), others to II or III as applicable. Quality requirements are highest on class I.

Examples of classes of piping systems as per DNV rules are presented in the table below.

Table 5-2 Classes of piping systems as per DNV rules

Media	Class I		Class II		Class III	
	MPa (bar)	°C	MPa (bar)	°C	MPa (bar)	°C
Steam	> 1.6 (16)	or > 300	< 1.6 (16)	and < 300	< 0.7 (7)	and < 170
Flammable fluid	> 1.6 (16)	or > 150	< 1.6 (16)	and < 150	< 0.7 (7)	and < 60
Other media	> 4 (40)	or > 300	< 4 (40)	and < 300	< 1.6 (16)	and < 200

5.5 Insulation

The following pipes shall be insulated:

- All trace heated pipes
- Exhaust gas pipes
- Exposed parts of pipes with temperature > 60°C

Insulation is also recommended for:

- Pipes between engine or system oil tank and lubricating oil separator
- Pipes between engine and jacket water preheater

5.6 Local gauges

Local thermometers should be installed wherever a new temperature occurs, i.e. before and after heat exchangers, etc.

Pressure gauges should be installed on the suction and discharge side of each pump.

5.7 Cleaning procedures

Instructions shall be given at an early stage to manufacturers and fitters how different piping systems shall be treated, cleaned and protected.

5.7.1 Cleanliness during pipe installation

All piping must be verified to be clean before lifting it onboard for installation. During the construction time uncompleted piping systems shall be maintained clean. Open pipe ends should be temporarily closed. Possible debris shall be removed with a suitable method. All tanks must be inspected and found clean before filling up with fuel, oil or water.

Piping cleaning methods are summarised in table below:

Table 5-3 Pipe cleaning

System	Methods
Fuel oil	A,B,C,D,F
Lubricating oil	A,B,C,D,F
Starting air	A,B,C
Cooling water	A,B,C
Exhaust gas	A,B,C
Charge air	A,B,C

1) In case of carbon steel pipes

Methods applied during prefabrication of pipe spools

A = Washing with alkaline solution in hot water at 80°C for degreasing (only if pipes have been greased)

B = Removal of rust and scale with steel brush (not required for seamless precision tubes)

D = Pickling (not required for seamless precision tubes)

Methods applied after installation onboard

C = Purging with compressed air

F = Flushing

5.7.2 Fuel oil pipes

Before start up of the engines, all the external piping between the day tanks and the engines must be flushed in order to remove any foreign particles such as welding slag.

Disconnect all the fuel pipes at the engine inlet and outlet . Install a temporary pipe or hose to connect the supply line to the return line, bypassing the engine. The pump used for flushing should have high enough capacity to ensure highly turbulent flow, minimum same as the max nominal flow. Heaters, automatic filters and the viscosimeter should be bypassed to prevent damage caused by debris in the piping. The automatic fuel filter must not be used as flushing filter.

The pump used should be protected by a suction strainer. During this time the welds in the fuel piping should be gently knocked at with a hammer to release slag and the filter inspected and carefully cleaned at regular intervals.

The cleanliness should be minimum ISO 4406 (c) 20/18/15, NAS9. A measurement certificate shows required cleanliness has been reached there is still risk that impurities may occur after a time of operation.

Note! The engine must not be connected during flushing.

5.7.3 Lubricating oil pipes

Flushing of the piping and equipment built on the engine is not required and flushing oil shall not be pumped through the engine oil system (which is flushed and clean from the factory).

It is however acceptable to circulate the flushing oil via the engine sump if this is advantageous. Cleanliness of the oil sump shall be verified after completed flushing and is acceptable when the cleanliness has reached a level in accordance with ISO 4406 (c) 21/19/15, NAS10. All pipes connected to the engine, the engine wet sump or to the external engine wise oil tank shall be flushed. Oil used for filling shall have a cleanliness of ISO 4406 (c) 21/19/15, NAS10.

Note! The engine must not be connected during flushing

5.7.4 Pickling

Prefabricated pipe spools are pickled before installation onboard.

Pipes are pickled in an acid solution of 10% hydrochloric acid and 10% formaline inhibitor for 4-5 hours, rinsed with hot water and blown dry with compressed air.

After acid treatment the pipes are treated with a neutralizing solution of 10% caustic soda and 50 grams of trisodiumphosphate per litre of water for 20 minutes at 40...50°C, rinsed with hot water and blown dry with compressed air.

Great cleanliness shall be approved in all work phases after completed pickling.

5.8 Flexible pipe connections

All external pipes must be precisely aligned to the fitting or the flange of the engine to minimize causing external forces to the engine connection.

Adding adapter pieces to the connection between the flexible pipe and engine, which are not approved by Wärtsilä are forbidden. Observe that the pipe clamp for the pipe outside the flexible connection must be very rigid and welded to the steel structure of the foundation to prevent vibrations and external forces to the connection, which could damage the flexible connections and transmit noise. The support must be close to the flexible connection. Most problems with bursting of the flexible connection originate from poor clamping.

Proper installation of pipe connections between engines and ship's piping to be ensured.

- Flexible pipe connections must not be twisted
- Installation length of flexible pipe connections must be correct
- Minimum bending radius must be respected
- Piping must be concentrically aligned
- When specified, the flow direction must be observed
- Mating flanges shall be clean from rust, burrs and anticorrosion coatings
- If not otherwise instructed, bolts are to be tightened crosswise in several stages
- Painting of flexible elements is not allowed
- Rubber bellows must be kept clean from oil and fuel
- The piping must be rigidly supported close to the flexible piping connections.

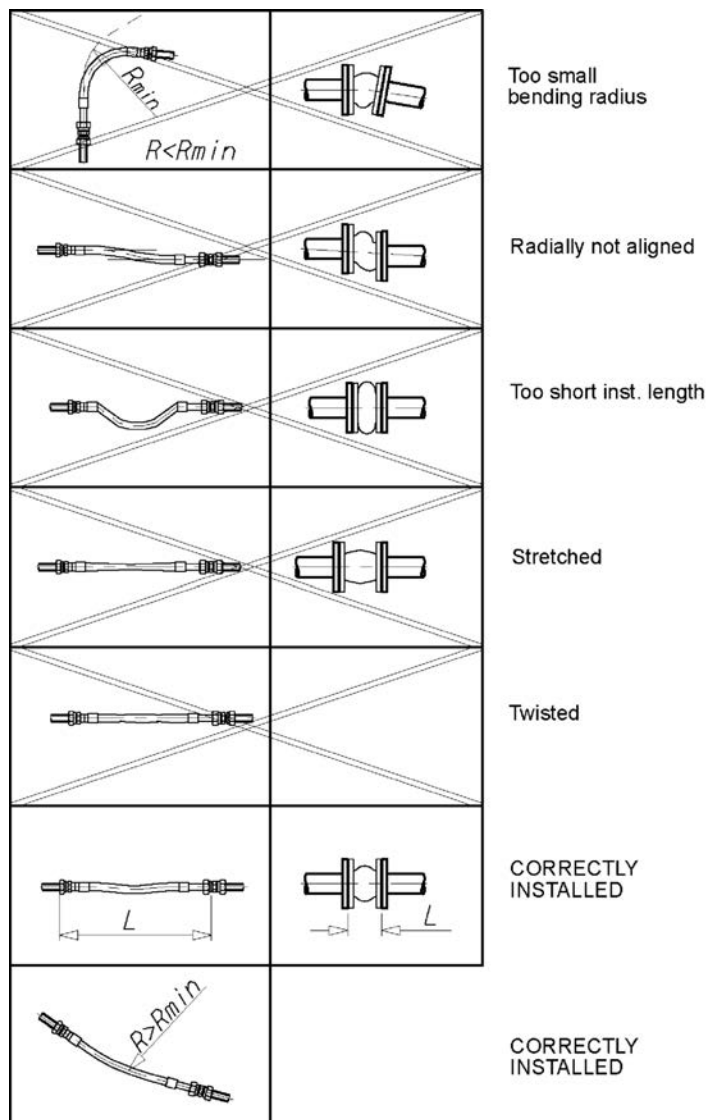

Fig 5-1 Flexible hoses

Drawing V60L0796 below is showing how pipes shall be clamped.

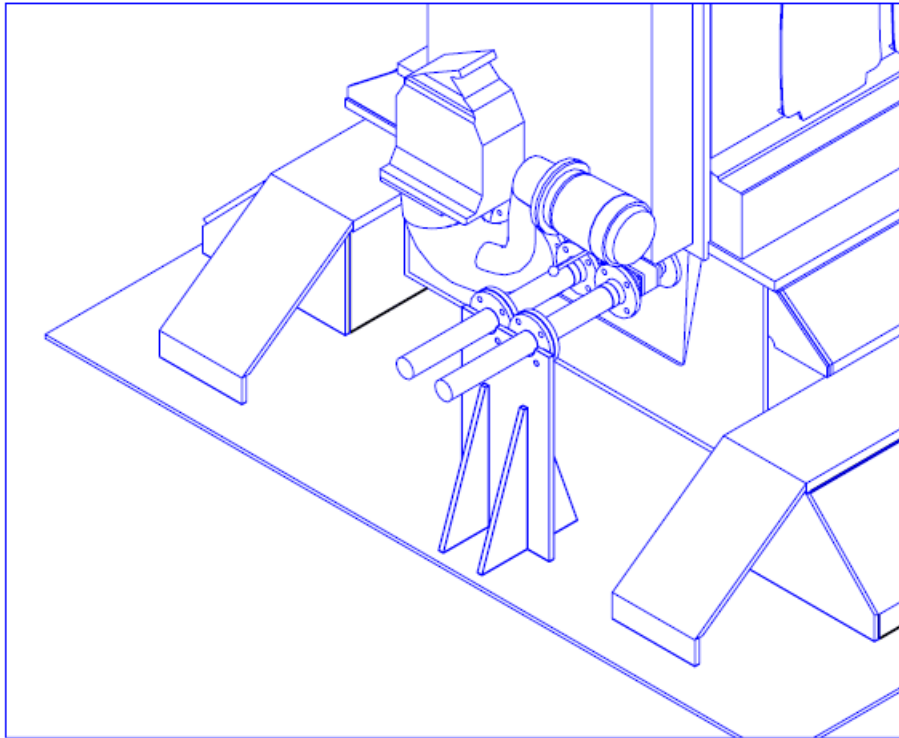

Fig 5-2 Flexible pipe connections (V60L0796)

NOTE



Pressurized flexible connections carrying flammable fluids or compressed air have to be type approved.

5.9 Clamping of pipes

It is very important to fix the pipes to rigid structures next to flexible pipe connections in order to prevent damage caused by vibration. The following guidelines should be applied:

- Pipe clamps and supports next to the engine must be very rigid and welded to the steel structure of the foundation.
- The first support should be located as close as possible to the flexible connection. Next support should be 0.3-0.5 m from the first support.
- First three supports closest to the engine or generating set should be fixed supports. Where necessary, sliding supports can be used after these three fixed supports to allow thermal expansion of the pipe.
- Supports should never be welded directly to the pipe. Either pipe clamps or flange supports should be used for flexible connection.

Examples of flange support structures are shown in [Flange supports of flexible pipe connections](#). A typical pipe clamp for a fixed support is shown in Figure 5-4. Pipe clamps must be made of steel; plastic clamps or similar may not be used.

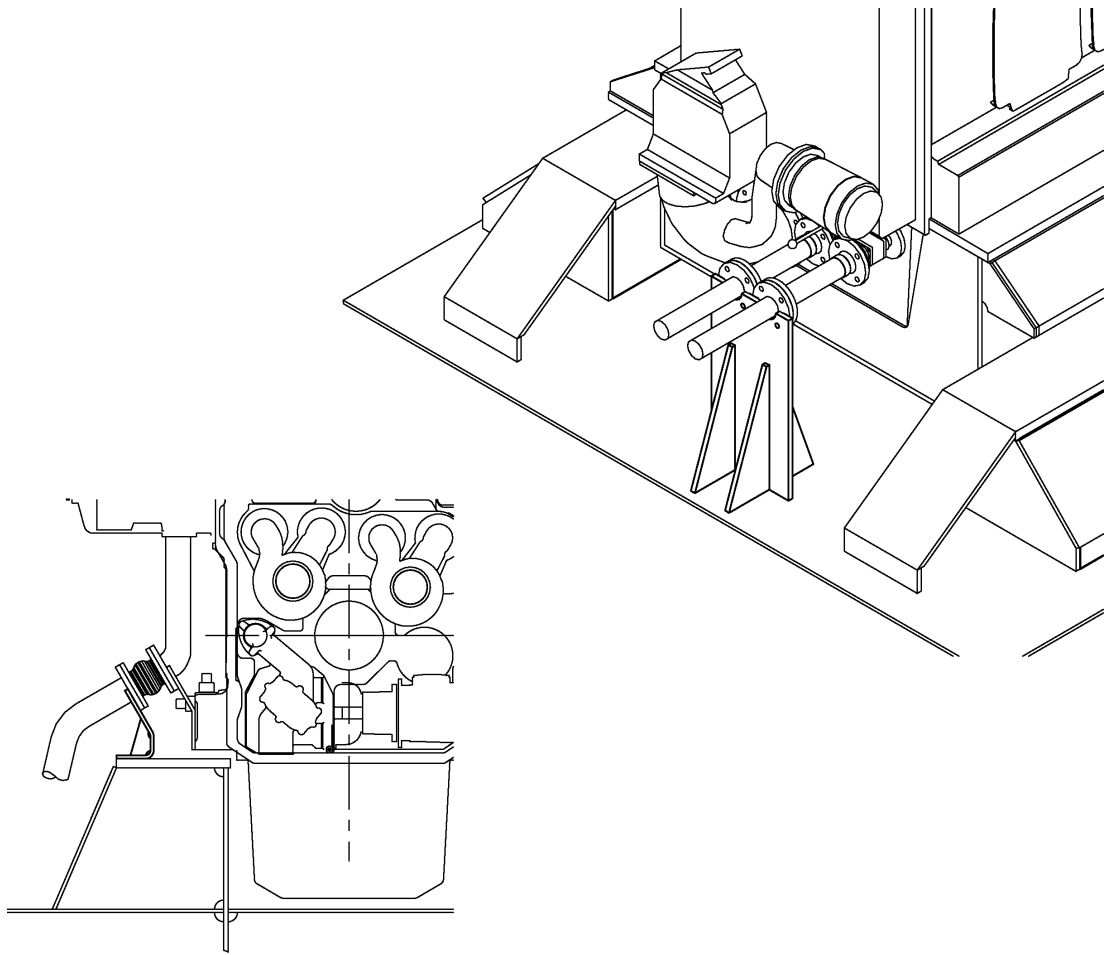
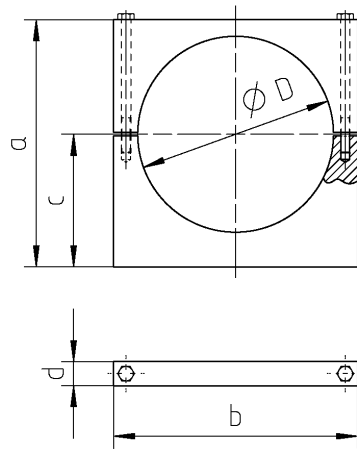

Fig 5-3 Flange supports of flexible pipe connections V60L0796

SUPPORTS AFTER FLEXIBLE BELLOW (FIXED) DN 25-300



DN	d_v mm	D mm	a mm	b mm	c mm	d mm	BOLTS
25	33.7	35	150	80	120	25	M10x50
32	42.4	43	150	75	120	25	M10x50
40	48.3	48	154.5	100	115	25	M12x60
50	60.3	61	185	100	145	25	M12x60
65	76.1	76.5	191	115	145	25	M12x70
80	88.9	90	220	140	150	30	M12x90
100	114.3	114.5	196	170	121	25	M12x100
125	139.7	140	217	200	132	30	M16x120
150	168.3	170	237	240	132	30	M16x140
200	219.1	220	295	290	160	30	M16x160
250	273.0	274	355	350	190	30	M16x200
① 300	323.9	325	410	405	220	40	M16x220

d_v = Pipe outer diameter

Fig 5-4 Pipe clamp for fixed support (V61H0842A)

This page intentionally left blank

6. Fuel Oil System

6.1 Acceptable fuel characteristics

The fuel specifications are based on the ISO 8217:2017 (E) standard. Observe that a few additional properties not included in the standard are listed in the tables. For maximum fuel temperature before the engine, see chapter "Technical Data".

The fuel shall not contain any added substances or chemical waste, which jeopardizes the safety of installations or adversely affects the performance of the engines or is harmful to personnel or contributes overall to air pollution.

6.1.1 Marine Diesel Fuel (MDF)

The fuel specification is based on the ISO 8217:2017(E) standard and covers the fuel grades ISO-F-DMX, DMA, DFA, DMZ, DFZ, DMB and DFB. These fuel grades are referred to as MDF (Marine Diesel Fuel).

The distillate grades mentioned above can be described as follows:

- **DMX:** A fuel quality which is suitable for use at ambient temperatures down to $-15\text{ }^{\circ}\text{C}$ without heating the fuel. Especially in merchant marine applications its use is restricted to lifeboat engines and certain emergency equipment due to reduced flash point. The low flash point which is not meeting the SOLAS requirement can also prevent the use in other marine applications, unless the fuel system is built according to special requirements. Also the low viscosity (min. 1.4 cSt) can prevent the use in engines unless the fuel can be cooled down enough to meet the min. injection viscosity limit of the engine.
- **DMA:** A high quality distillate, generally designated MGO (Marine Gas Oil) in the marine field.
- **DFA:** A similar quality distillate fuel compared to DMA category fuels but a presence of max. 7,0% v/v of Fatty acid methyl ester (FAME) is allowed.
- **DMZ:** A high quality distillate, generally designated MGO (Marine Gas Oil) in the marine field. An alternative fuel grade for engines requiring a higher fuel viscosity than specified for DMA grade fuel.
- **DFZ:** A similar quality distillate fuel compared to DMZ category fuels but a presence of max. 7,0% v/v of Fatty acid methyl ester (FAME) is allowed.
- **DMB:** A general purpose fuel which may contain trace amounts of residual fuel and is intended for engines not specifically designed to burn residual fuels. It is generally designated MDO (Marine Diesel Oil) in the marine field.
- **DFB:** A similar quality distillate fuel compared to DMB category fuels but a presence of max. 7,0% v/v of Fatty acid methyl ester (FAME) is allowed.

6.1.1.1 Table Light fuel oils

Table 6-1 Distillate fuel specifications

Characteristics	Unit	Lim- it	Category ISO-F						Test meth- od(s) and ref- erences
			DMX	DMA	DFA	DMZ	DFZ	DMB	
Kinematic viscosity at 40 °C ¹⁾	mm ² /s ^{a)}	Max	5,500	6,000	6,000	11,00			ISO 3104
		Min	1,400 ¹⁾	2,000	3,000	2,000			
Density at 15 °C	kg/m ³	Max	-	890,0	890,0	900,0			ISO 3675 or ISO 12185

Characteristics	Unit	Limit	Category ISO-F						Test method(s) and references	
			DMX	DMA	DFA	DMZ	DFZ	DVB		DFB
Cetane index		Min	45	40	40	35			ISO 4264	
Sulphur ^{b, k)}	% m/m	Max	1,00	1,00	1,00	1,50			ISO 8754 or ISO 14596, ASTM D4294	
Flash point	°C	Min	43,0 ^{l)}	60,0	60,0	60,0			ISO 2719	
Hydrogen sulfide	mg/kg	Max	2,00	2,00	2,00	2,00			IP 570	
Acid number	mg KOH/g	Max	0,5	0,5	0,5	0,5			ASTM D664	
Total sediment by hot filtration	% m/m	Max	-	-	-	0,10 ^{c)}			ISO 10307-1	
Oxidation stability	g/m ³	Max	25	25	25	25 ^{d)}			ISO 12205	
Fatty acid methyl ester (FAME) ^{e)}	% v/v	Max	-	-	7,0	-	7,0	-	7,0	ASTM D7963 or IP 579
Carbon residue – Micro method on 10% distillation residue	% m/m	Max	0,30	0,30	0,30	-			ISO 10370	
Carbon residue – Micro method	% m/m	Max	-	-	-	0,30			ISO 10370	
Cloud point ^{f)}	winter	°C	Max	-16	Report	Report	-		ISO 3015	
	summer			-16	-	-	-			
Cold filter plugging point ^{f)}	winter	°C	Max	-	Report	Report	-		IP 309 or IP 612	
	summer			-	-	-	-			
Pour point ^{f)}	winter	°C	Max	-	-6	-6	0		ISO 3016	
	summer			-	0	0	6			
Appearance		-	Clear and bright ^{g)}				^{c)}		-	
Water	% v/v	Max	-	-	-	0,30 ^{c)}			ISO 3733 or ASTM D6304-C ^{m)}	
Ash	% m/m	Max	0,010	0,010	0,010	0,010			ISO 6245	
Lubricity, corr. wear scar diam. ^{h)}	µm	Max	520	520	520	520 ^{d)}			ISO 12156-1	

NOTE

- a) 1 mm²/s = 1 cSt.
- b) Notwithstanding the limits given, the purchaser shall define the maximum sulphur content in accordance with relevant statutory limitations.
- c) If the sample is not clear and bright, the total sediment by hot filtration and water tests shall be required.
- d) If the sample is not clear and bright, the Oxidation stability and Lubricity tests cannot be undertaken and therefore, compliance with this limit cannot be shown.
- e) See ISO 8217:2017(E) standard for details.
- f) Pour point cannot guarantee operability for all ships in all climates. The purchaser should confirm that the cold flow characteristics (pour point, cloud point, cold filter clogging point) are suitable for ship's design and intended voyage.
- g) If the sample is dyed and not transparent, see ISO 8217:2017(E) standard for details related to water analysis limits and test methods.
- h) The requirement is applicable to fuels with a sulphur content below 500 mg/kg (0,050 % m/m).

Additional notes not included in the ISO 8217:2017(E) standard:

- i) Low min. viscosity of 1,400 mm²/s can prevent the use ISO-F-DMX category fuels in Wärtsilä® 4-stroke engines unless a fuel can be cooled down enough to meet the specified min. injection viscosity limit.
- j) Allowed kinematic viscosity before the injection pumps for this engine type is 1,8 - 24 mm²/s.
- k) There doesn't exist any minimum sulphur content limit for Wärtsilä® 4-stroke diesel engines and also the use of Ultra Low Sulphur Diesel (ULSD) is allowed provided that the fuel quality fulfils other specified properties.
- l) Low flash point of min. 43 °C can prevent the use ISO-F-DMX category fuels in Wärtsilä® engines in marine applications unless the ship's fuel system is built according to special requirements allowing the use or that the fuel supplier is able to guarantee that flash point of the delivered fuel batch is above 60 °C being a requirement of SOLAS and classification societies.
- m) Alternative test method.

6.1.2 0,10% m/m sulphur fuels for SECA areas

Due to the tightened sulphur emission legislation being valid since 01.01.2015 in the specified SECA areas many new max. 0,10 % m/m sulphur content fuels have entered the market. Some of these fuels are not pure distillate fuels, but contain new refinery streams, like hydrocracker bottoms or can also be blends of distillate and residual fuels. The new 0,10 % m/m sulphur fuels are also called as Ultra Low Sulphur Fuel Oils (ULSFO) or “hybrid” fuels, since those can contain properties of both distillate and residual fuels. In the existing ISO 8217:2017(E) standard the fuels are classed as RMA 10, RMB 30 or RMD 80, if not fulling the DM grade category requirements, though from their properties point of view this is generally not an optimum approach.

These fuels can be used in the Wärtsilä 20 engine type, but special attention shall be paid to optimum operating conditions. See also Services Instruction WS02Q312.

Characteristics	Unit	RMA 10	RMB 30	RMD 80	Test method reference
Kinematic viscosity bef. inj. pumps ^{c)}	mm ² /s a)	6,0 - 24	6,0 - 24	6,0 - 24	-
Kinematic viscosity at 50 °C, max.	mm ² /s a)	10,00	30,00	80,00	ISO 3104
Density at 15 °C, max.	kg/m ³	920,0	960,0	975,0	ISO 3675 or ISO 12185
CCAI, max. ^{e)}	-	850	860	860	ISO 8217, Annex F
Sulphur, max. ^{b), f)}	% m/m	0,10	0,10	0,10	ISO 8574 or ISO 14596
Flash point, min.	°C	60,0	60,0	60,0	ISO 2719
Hydrogen sulfide, max.	mg/kg	2,00	2,00	2,00	IP 570
Acid number, max.	mg KOH/g	2,5	2,5	2,5	ASTM D664
Total sediment existent, max.	% m/m	0,10	0,10	0,10	ISO 10307-2
Carbon residue, micro method, max.	% m/m	2,50	10,00	14,00	ISO 10370
Asphaltenes, max. ^{c)}	% m/m	1,5	6,0	8,0	ASTM D3279
Pour point (upper), max., winter quality ^{d)}	°C	0	0	30	ISO 3016
Pour point (upper), max., summer quality ^{d)}	°C	6	6	30	ISO 3016
Water max.	% v/v	0,30	0,50	0,50	ISO 3733 or ASTM D6304-C ^{c)}
Water bef. engine, max. ^{c)}	% v/v	0,30	0,30	0,30	ISO 3733 or ASTM D6304-C ^{c)}
Ash, max.	% m/m	0,040	0,070	0,070	ISO 6245 or LP1001 ^{c, h)}
Vanadium, max. ^{f)}	mg/kg	50	150	150	IP 501, IP 470 or ISO 14597
Sodium, max. ^{f)}	mg/kg	50	100	100	IP 501 or IP 470
Sodium bef. engine, max. ^{c, f)}	mg/kg	30	30	30	IP 501 or IP 470

Characteristics	Unit	RMA 10	RMB 30	RMD 80	Test method reference
Aluminium + Silicon, max.	mg/kg	25	40	40	IP 501, IP 470 or ISO 10478
Aluminium + Silicon bef. engine, max. ^{c)}	mg/kg	15	15	15	IP 501, IP 470 or ISO 10478
Used lubricating oil: ^{g)}					
- Calcium, max.	mg/kg	30	30	30	IP 501 or IP 470
- Zinc, max.	mg/kg	15	15	15	IP 501 or IP 470
- Phosphorus, max.	mg/kg	15	15	15	IP 501 or IP 500

NOTE



a) 1 mm²/s = 1 cSt.

b) The purchaser shall define the maximum sulphur content in accordance with relevant statutory limitations.

c) Additional properties specified by the engine manufacturer, which are not included in the ISO 8217:2017(E) standard.

d) Purchasers shall ensure that this pour point is suitable for the equipment on board / at the plant, especially if the ship operates / plant is located in cold climates.

e) Straight run residues show CCAI values in the 770 to 840 range and are very good ignitors. Cracked residues delivered as bunkers may range from 840 to – in exceptional cases – above 900. Most bunkers remain in the max. 850 to 870 range at the moment. CCAI value cannot always be considered as an accurate tool to determine fuels' ignition properties, especially concerning fuels originating from modern and more complex refinery processes.

f) Sodium contributes to hot corrosion on exhaust valves when combined with high sulphur and vanadium contents. Sodium also strongly contributes to fouling of the exhaust gas turbine blading at high loads. The aggressiveness of the fuel depends on its proportions of sodium and vanadium, but also on the total amount of ash. Hot corrosion and deposit formation are, however, also influenced by other ash constituents. It is therefore difficult to set strict limits based only on the sodium and vanadium content of the fuel. Also a fuel with lower sodium and vanadium contents than specified above, can cause hot corrosion on engine components.

g) The fuel shall be free from used lubricating oil (ULO). A fuel shall be considered to contain ULO when either one of the following conditions is met:

- Calcium > 30 mg/kg and zinc > 15 mg/kg OR
- Calcium > 30 mg/kg and phosphorus > 15 mg/kg

h) Ashing temperatures can vary when different test methods are used having an influence on the test result.

6.1.3 Heavy Fuel Oil (HFO)

Residual fuel grades are referred to as HFO (Heavy Fuel Oil). The fuel specification HFO 2 is based on the ISO 8217:2017(E) standard and covers the categories ISO-F-RMA 10 to RMK 700. Fuels fulfilling the specification HFO 1 permit longer overhaul intervals of specific engine components than HFO 2.

6.1.3.1 Table Heavy fuel oils

Table 6-2 Residual fuel specifications

Characteristics	Unit	Limit HFO 1	Limit HFO 2	Test method reference
Kinematic viscosity bef. inj. pumps ^{d)}	mm ² /s ^{b)}	20 ± 4	20 ± 4	-
Kinematic viscosity at 50 °C, max.	mm ² /s ^{b)}	700,0	700,0	ISO 3104
Density at 15 °C, max.	kg/m ³	991,0 / 1010,0 ^{a)}	991,0 / 1010,0 ^{a)}	ISO 3675 or ISO 12185
CCAI, max. ^{f)}	-	850	870	ISO 8217, Annex F
Sulphur, max. ^{c, g)}	%m/m	Statutory requirements		ISO 8754 or ISO 14596
Flash point, min.	°C	60,0	60,0	ISO 2719
Hydrogen sulfide, max.	mg/kg	2,00	2,00	IP 570
Acid number, max.	mg KOH/g	2,5	2,5	ASTM D664
Total sediment aged, max.	%m/m	0,10	0,10	ISO 10307-2
Carbon residue, micro method, max.	%m/m	15,00	20,00	ISO 10370
Asphaltenes, max. ^{d)}	%m/m	8,0	14,0	ASTM D3279
Pour point (upper), max. ^{e)}	°C	30	30	ISO 3016
Water, max. ^{d)}	%V/V	0,50	0,50	ISO 3733 or ASTM D6304-C ^{d)}
Water before engine, max. ^{d)}	%V/V	0,30	0,30	ISO 3733 or ASTM D6304-C ^{d)}
Ash, max.	%m/m	0,050	0,150	ISO 6245 or LP1001 ^{d, i)}
Vanadium, max. ^{g)}	mg/kg	100	450	IP 501, IP 470 or ISO 14597
Sodium, max. ^{g)}	mg/kg	50	100	IP 501 or IP 470
Sodium before engine, max. ^{d, g)}	mg/kg	30	30	IP 501 or IP 470
Aluminium + Silicon, max. ^{d)}	mg/kg	30	60	IP 501, IP 470 or ISO 10478
Aluminium + Silicon before engine, max. ^{d)}	mg/kg	15	15	IP 501, IP 470 or ISO 10478
Used lubricating oil ^{h)}				
- Calcium, max.	mg/kg	30	30	IP 501 or IP 470
- Zinc, max.	mg/kg	15	15	IP 501 or IP 470
- Phosphorus, max.	mg/kg	15	15	IP 501 or IP 500

NOTE

a) Max. 1010 kg/m³ at 15 °C, provided the fuel treatment system can reduce water and solids (sediment, sodium, aluminium, silicon) before engine to the specified levels.

b) 1 mm²/s = 1 cSt.

c) The purchaser shall define the maximum sulphur content in accordance with relevant statutory limitations.

d) Additional properties specified by the engine manufacturer, which are not included in the ISO 8217:2017(E) standard.

e) Purchasers shall ensure that this pour point is suitable for the equipment on board / at the plant, especially if the ship operates / plant is located in cold climates.

f) Straight run residues show CCAI values in the 770 to 840 range and are very good ignitors. Cracked residues delivered as bunkers may range from 840 to – in exceptional cases – above 900. Most bunkers remain in the max. 850 to 870 range at the moment. CCAI value cannot always be considered as an accurate tool to determine fuels' ignition properties, especially concerning fuels originating from modern and more complex refinery processes.

g) Sodium contributes to hot corrosion on exhaust valves when combined with high sulphur and vanadium contents. Sodium also strongly contributes to fouling of the exhaust gas turbine blading at high loads. The aggressiveness of the fuel depends on its proportions of sodium and vanadium, but also on the total amount of ash. Hot corrosion and deposit formation are, however, also influenced by other ash constituents. It is therefore difficult to set strict limits based only on the sodium and vanadium content of the fuel. Also a fuel with lower sodium and vanadium contents than specified above, can cause hot corrosion on engine components.

h) The fuel shall be free from used lubricating oil (ULO). A fuel shall be considered to contain ULO when either one of the following conditions is met:

- Calcium > 30 mg/kg and zinc > 15 mg/kg OR
- Calcium > 30 mg/kg and phosphorus > 15 mg/kg

i) The ashing temperatures can vary when different test methods are used having an influence on the test result.

6.1.4**Biofuel oils****Liquid biofuel characteristics and specifications**

The diesel engines are designed and developed with a dedicated kit for continuous operation, without reduction in the rated output, on liquid biofuels with the properties included in the table 6.1.4.1, table 6.1.4.2 and table 6.1.4.3.

NOTE

Liquid biofuels included in the table 6.1.4.1 and table 6.1.4.2 have typically lower heating value than fossil fuels, therefore the capacity of fuel injection system influencing on guaranteed engine output must be checked case by case.

NOTE

Liquid biofuels included in the table 6.1.4.3 have a low density, while the capacity of fuel injection system influencing on guaranteed engine output must be checked case by case. The flash point can also be lower than 60 °C which is a requirement of SOLAS and Classification societies (for marine applications). Therefore its use might be prohibited.

Acceptable storage period for liquid biofuels excluding products which belong to the category being presented in 6.1.4.3 can be significantly shorter than storage period specified for fossil fuels. Some biodiesel manufacturers are referring to max. one month storage period. After that acidity starts to increase leading to faster oxidation rate of the fuel.

Blending of different fuel qualities:

Crude and refined liquid biofuels (table 6.1.4.1) must not be mixed with fossil fuels, but have to be used as such.

Mixing of crude and refined liquid biofuel (table 6.1.4.1) and distillate fuel will increase the risk of cavitation in the fuel system, since required fuel temperature before engine is normally 80 - 90 °C. At this temperature light fractions of distillate fuel have already started to evaporate.

Mixing of crude and refined liquid biofuel (table 6.1.4.1) with residual fuel will increase the risk of biofuel component polymerization leading to formation of gummy deposits to engine component surfaces, because of elevated temperature.

The use of residual fuel requires much higher operating temperature than the use of crude and refined liquid biofuel, i.e. normally above 100 °C in order to achieve a proper fuel injection viscosity.

Required fuel temperatures:

Crude and refined liquid biofuel (table 6.1.4.1) temperature before an engine is an utmost important operating parameter. Too low temperature will cause solidification of fatty acids leading to clogging of filters, plug formation in the fuel system and even to fuel injection equipment component breakdowns. Too high fuel temperature will increase the risk of polymerization and formation of gummy deposits, especially in the presence of oxygen.

When operating on crude and refined liquid biofuels (table 6.1.4.1), it is utmost important to maintain a proper fuel temperature before fuel injection pumps in order to ensure safe operation of the engine and fuel system. The recommended fuel operating temperature depends on both the liquid biofuel quality and the degree of processing. E.g. many palm oil qualities require ~ 80 - 90 °C fuel temperature in order to achieve an expected lifetime of fuel injection equipment and to avoid fuel filter clogging. Some refined palm oil qualities are however behaving acceptably also at lower, ~ 70 - 75 °C operating temperature. For other types of crude and refined liquid biofuels the temperature requirement can be slightly different and must be confirmed before the use.

For fuel qualities included in the table 6.1.4.2 and table 6.1.4.3 fuel temperature before fuel injection pumps is limited to max. 45 °C.

6.1.4.1 Crude and refined liquid biofuels

The specification included in the table below is valid for crude and refined liquid biofuels, like palm oil, coconut oil, copra oil, rape seed oil, jatropha oil, fish oil, etc.

Table 6-3 Liquid biofuel specification for crude and refined biofuels (residual fuel substitutes)

Property	Unit	Limit	Test method reference
Viscosity, max.	mm ² /s @ 50 °C	70 ¹⁾	ISO 3104
	mm ² /s @ 80 °C	15 ¹⁾	
Injection viscosity, min.	mm ² /s	1.8 ²⁾	ISO 3104

Property	Unit	Limit	Test method reference
Injection viscosity, max.	mm ² /s	24	ISO 3104
Density, max.	kg/m ³ @ 15 °C	940	ISO 3675 or ISO 12185
Ignition properties ³⁾		³⁾	FIA-100 FCA test
Sulphur, max.	% m/m	0.05	ISO 8754
Total sediment existent, max.	% m/m	0.05	ISO 10307-1
Water, max. before engine	% v/v	0.20	ISO 3733
Micro carbon residue, max.	% m/m	0.50	ISO 10370
Ash, max.	% m/m	0.05	ISO 6245 / LP1001 ⁴⁾
Phosphorus, max.	mg/kg	100	ISO 10478
Silicon, max.	mg/kg	15	ISO 10478
Alkali content (Na+K), max.	mg/kg	30	ISO 10478
Flash point (PMCC), min.	°C	60	ISO 2719
Cloud point, max.	°C	⁵⁾	ISO 3015
Cold filter plugging point, max.	°C	⁵⁾	IP 309
Copper strip corrosion (3 hrs @ 50 °C), max.	Rating	1b	ASTM D130
Steel corrosion (24 / 72 hours @ 20, 60 and 120 °C), max.	Rating	No signs of corrosion	LP 2902
Oxidation stability @ 110 °C, min.	h	17.0 ⁶⁾	EN 14112
Acid number, max.	mg KOH/g	15.0	ASTM D664
Strong acid number, max.	mg KOH/g	0.0	ASTM D664
Iodine number, max.	g iodine /100 g	120 ⁷⁾	ISO 3961
Synthetic polymers	% m/m	Report ⁸⁾	LP 2501

NOTE

- 1) If injection viscosity of max. 24 cSt cannot be achieved with an unheated fuel, fuel system has to be equipped with a heater ($\text{mm}^2/\text{s} = \text{cSt}$).
- 2) Min. viscosity limit at engine inlet in running conditions ($\text{mm}^2/\text{s} = \text{cSt}$).
- 3) Ignition properties have to be equal to or better than the requirements for fossil fuels, i.e., CI min. 35 for LFO and CCAI max. 870 for HFO.
- 4) Ashing temperatures can vary when different test methods are used having an influence on the test result.
- 5) Cloud point and cold filter plugging point have to be at least 10 °C below fuel injection temperature and the temperature in the whole fuel system has to be min. 10 – 15 °C higher than cloud point and cold filter plugging point.
- 6) A lower oxidation stability value down to min. 10 hours can be considered acceptable if other fuel properties, like cloud point, cold filter plugging point and viscosity support that. This needs to be decided case-by-case.
- 7) Iodine number of soyabean oil is somewhat higher, up to ~ 140, which is acceptable for specific that biofuel quality.
- 8) Biofuels originating from food industry can contain synthetic polymers, like e.g. styrene, propene and ethylene used in packing material. Such compounds can cause filter clogging and shall thus not be present in biofuels.

NOTE

If SCR or oxidation catalyst needs to be used the specification included in the table above does not apply, but the fuel quality requirements have to be discussed separately. The specification does not take into consideration Particulate Matter emission limits.

NOTE

The use of liquid biofuels fulfilling the table above requirements always require a NSR to be made.

6.1.4.2 Fatty acid methyl ester (FAME) / Biodiesel

Renewable refined liquid biofuels which are manufactured by using transesterification processes, can contain both vegetable and / or animal based feedstock and do normally show out very good physical and chemical properties. These fuels can be used provided that the specification included in the table below is fulfilled. International standards ASTM D 6751-06 or EN 14214:2012 (E) are typically used for specifying biodiesel quality.

Table 6-4 Fatty acid methyl ester (FAME) / Biodiesel specification based on the EN 14214:2012 standard

Property	Unit	Limit	Test method reference
Viscosity, min. - max.	mm^2/s @ 40 °C	3.5 - 5.0	EN ISO 3104
Injection viscosity, min.	mm^2/s	1.8 ¹⁾	EN ISO 3104
Density, min. - max.	kg/m^3 @ 15 °C	860 - 900	EN ISO 3675 / 12185
Cetane number, min.	-	51.0	EN ISO 5165

Property	Unit	Limit	Test method reference
Sulphur content, max.	mg/kg	10.0	EN ISO 20846 / 20884 / 13032
Sulphated ash content, max.	% m/m	0.02	ISO 3987
Total contamination, max.	mg/kg	24	EN 12662
Water content, max.	mg/kg	500	EN ISO 12937
Phosphorus content, max.	mg/kg	4.0	EN 14107
Group I metals (Na + K) content, max.	mg/kg	5.0	EN 14108 / EN 14109 / 14538
Group II metals (Ca + Mg) content, max.	mg/kg	5.0	EN 14538
Flash point, min.	°C	101	EN ISO 2719A / 3679
Cold filter plugging point, max. (climate dependent requirement)	°C	-20 → +5 ²⁾	EN 116
Oxidation stability @ 110 °C, min.	h	8.0	EN 14112
Copper strip corrosion (3 hrs @ 50 °C), max.	Rating	Class 1	EN ISO 2160
Acid value, max.	mg KOH/g	0.50	EN 14104
Iodine value, max.	g iodine/100 g	120	EN 14111 / 16300
FAME content, min.	% m/m	96.5	EN 14103
Linolenic acid methyl ester, max.	% m/m	12.0	EN 14103
Polyunsaturated (≥ 4 double bonds) methyl esters, max.	% m/m	1.00	EN 15779
Methanol content, max.	% m/m	0.20	EN 14110
Monoglyceride content, max.	% m/m	0.70	EN 14105
Diglyceride content, max.	% m/m	0.20	EN 14105
Triglyceride content, max.	% m/m	0.20	EN 14105
Free glycerol, max.	% m/m	0.02	EN 14105 / EN 14106
Total glycerol, max.	% m/m	0.25	EN 14105

NOTE



1) Min. limit at engine inlet in running conditions ($\text{mm}^2/\text{s} = \text{cSt}$).

2) Cold flow properties of renewable biodiesel can vary based on the geographical location and also based on the feedstock properties, which issues must be taken into account when designing the fuel system. For arctic climates even lower CFPP values down to -44 °C are specified.

NOTE



The use of liquid biofuels fulfilling the table above requirements always require a NSR to be made.

6.1.4.3

Paraffinic diesel fuels from synthesis and hydrotreatment

Paraffinic renewable distillate fuels originating from synthesis or hydrotreatment represent clearly a better quality than transesterified biodiesel and the comparison to biodiesel quality requirements is thus so relevant. The quality of the fuel qualities shall meet the EN 15940:2016

Class A requirements included in the table below. For arctic or severe winter climates additional or more stringent requirements are set concerning cold filter plugging point, cloud point, viscosity and distillation properties.

Table 6-5 Requirements for paraffinic diesel from synthesis or hydrotreatment based on the EN 15940:2016 standard

Property	Unit	Limit	Test method reference
Viscosity, min. - max.	mm ² /s @ 40 °C	2.0 - 4.5	EN ISO 3104
Injection viscosity, min.	mm ² /s	1.8 ¹⁾	EN ISO 3104
Density, min. - max.	kg/m ³ @ 15 °C	765 - 800 ²⁾	EN ISO 3675 / 12185
Cetane number, min.	-	70.0	EN 15195 / EN ISO 5165
Sulphur content, max.	mg/kg	5.0	EN ISO 20846 / 20884
Ash content, max.	% m/m	0.010	EN ISO 6245
Total contamination, max.	mg/kg	24	EN 12662
Water content, max.	mg/kg	200	EN ISO 12937
Total aromatics, max.	% m/m	1.1	EN 12916
Carbon residue on 10% distillation residue, max.	% m/m	0.30	EN ISO 10370
Lubricity, max.	µm	460	EN ISO 12156-1
Flash point, min.	°C	55 ³⁾	EN ISO 2719
Cold filter plugging point, max. (climate dependent requirement)	°C	-20 → +5 ⁴⁾	EN 116 / 16329
Oxidation stability, max. Oxidation stability, min.	g/m ³ h	25 20 ⁵⁾	EN ISO 12205 EN 15751
Copper strip corrosion (3 hrs @ 50 °C), max.	Rating	Class 1	EN ISO 2160
Distillation			EN ISO 3405 / 3924
% v/v recovered @ 250 °C, max.	% v/v	65	
% v/v recovered @ 350 °C, min.	% v/v	85	
95 % v/v recovered at, max.	°C	360	
Distillation % v/v recovered @ 250 °C, max. % v/v recovered @ 350 °C, min. 95 % v/v recovered at, max.	% v/v % v/v °C	65 85 360	EN ISO 3405 / 3924
FAME content, max.	% v/v	7.0	EN 14078

NOTE

- 1) Min. limit at engine inlet in running conditions ($\text{mm}^2/\text{s} = \text{cSt}$).
- 2) Due to low density the guaranteed engine output of pure hydrotreated fuel / GTL has to be confirmed case by case.
- 3) The use in marine applications is allowed provided that a fuel supplier can guarantee min. flash point of $60\text{ }^\circ\text{C}$.
- 4) Cold flow properties of renewable biodiesel can vary based on the geographical location and also based on the feedstock properties, which issues must be taken into account when designing the fuel system. For arctic or severe winter climates even lower CFPP values down to $-44\text{ }^\circ\text{C}$ are specified.
- 5) Additional requirement if the fuel contains $> 2.0\%$ v/v of FAME.

NOTE

The use of liquid biofuels fulfilling the table above requirements is allowed in all Wärtsilä medium-speed diesel and DF engines both as main fuel, back-up fuel and pilot fuel.

6.2 Internal fuel oil system

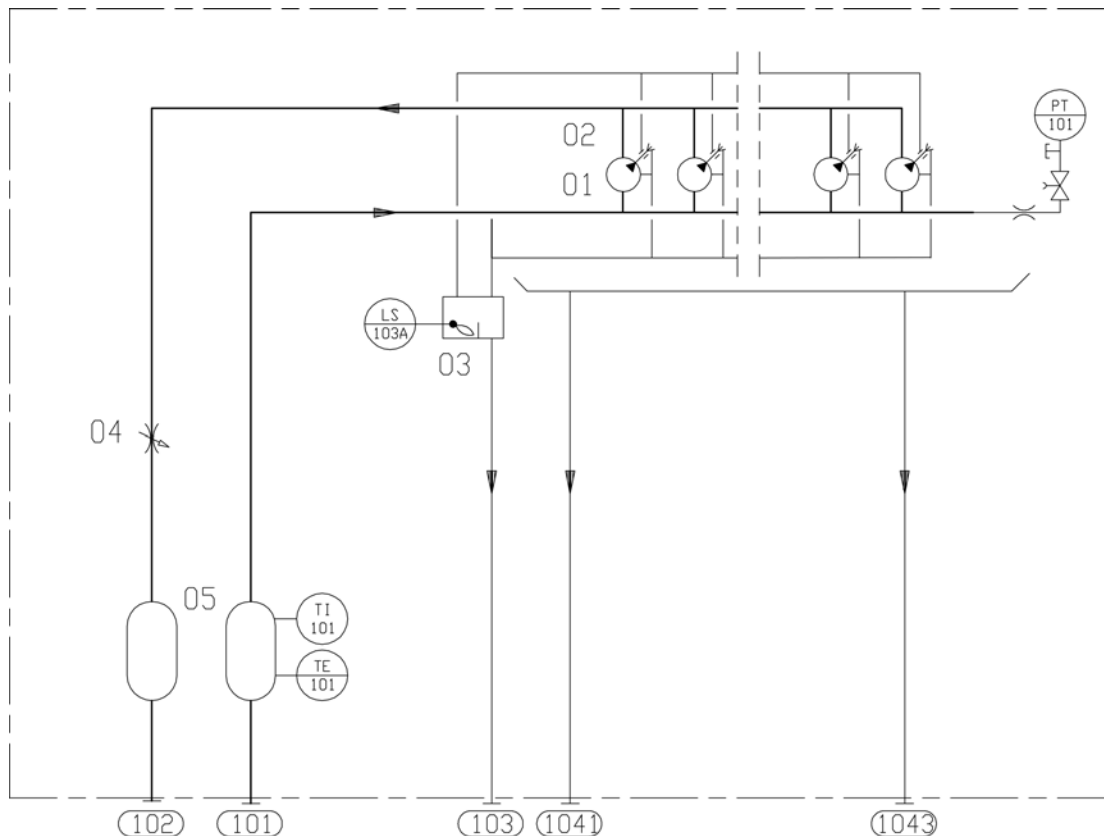

NOTE



T = Test plug

Fig 6-1 Internal fuel oil system, HFO/LFO (DAAF382587B) - UNIC C1

System components:			
01	Injection pump	04	Adjustable orifice
02	Injection valve	05	Pulse damper
03	Fuel leakage collector		

Sensors and indicators:	
PT101	Fuel oil leakage, engine inlet
TE101	Fuel oil temperature, engine inlet
TI101	Fuel oil temperature, engine inlet
LS103A	Fuel oil leakage, clean primary

Pipe connections:		Size	Standard
101	Fuel inlet	OD18	DIN 2353
102	Fuel outlet	OD18	DIN 2353
103	Leak fuel drain, clean fuel	OD18	DIN 2353
1041	Leak fuel drain, dirty fuel free end	OD18	DIN 2353
1043	Leak fuel drain, dirty fuel flywheel end	OD18	DIN 2353

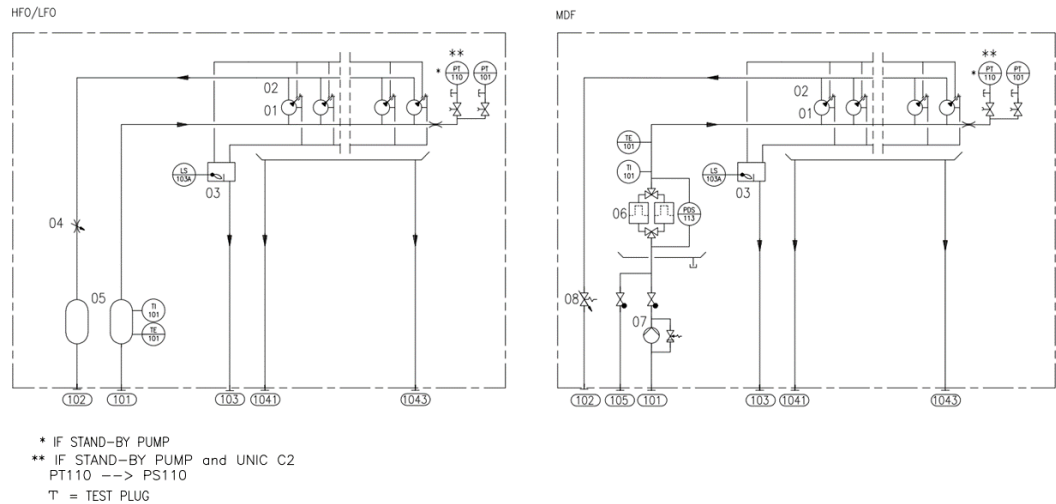

Fig 6-2 Internal fuel system, MDF & HFO (DAAF395502D) - UNIC C2 & UNIC 2.0

System components:			
01	Injection pump	05	Pulse damper
02	Injection valve	06	Duplex fine filter
03	Fuel leakage collector	07	Engine driven fuel feed pump
04	Adjustable orifice	08	Pressure regulating valve

Sensors and indicators:			
PT101	Fuel oil pressure, engine inlet	PDS113	Fuel oil filter, pressure difference switch
*PT110	Fuel oil pressure, stand-by pump (optional)	TE101	Fuel oil temperature, engine inlet
LS103A	Fuel oil leakage, clean primary	TI101	Fuel oil temperature, engine inlet
**PS110	Fuel oil stand-by pump start		

Pipe connections		Size
101	Fuel inlet	OD28
102	Fuel outlet	OD28
103	Leak fuel drain, clean fuel	OD18
1041	Leak fuel drain, dirty fuel free end	OD22
1043	Leak fuel drain, dirty fuel flywheel end	OD18
105	Fuel stand-by connection	OD22

The engine can be specified to either operate on heavy fuel oil (HFO) or on marine diesel fuel (MDF). The engine is designed for continuous operation on HFO. It is however possible to operate HFO engines on MDF intermittently without alternations. If the operation of the engine is changed from HFO to continuous operation on MDF, then a change of exhaust valves from Nimonic to Stellite is recommended.

HFO engines are equipped with an adjustable orifice in the fuel return line on the engine. For engines installed in the same fuel feed circuit, it is essential to distribute the fuel correctly to the engines. For this purpose the pressure drop differences around engines shall be compensated with the adjustable orifice.

MDF engines, with an engine driven fuel feed pump, are equipped with a pressure control valve in the fuel return line on the engine. This pressure control valve maintains desired pressure before the injection pumps.

6.2.1 Leak fuel system

Clean leak fuel from the injection valves and the injection pumps is collected on the engine and drained by gravity through a clean leak fuel connection. The clean leak fuel can be re-used without separation. The quantity of clean leak fuel is given in chapter *Technical data*.

Other possible leak fuel and spilled water and oil is separately drained from the hot-box through dirty fuel oil connections and it shall be led to a sludge tank.

6.3 External fuel oil system

The design of the external fuel system may vary from ship to ship, but every system should provide well cleaned fuel of correct viscosity and pressure to each engine. Temperature control is required to maintain stable and correct viscosity of the fuel before the injection pumps (see *Technical data*). Sufficient circulation through every engine connected to the same circuit must be ensured in all operating conditions.

The fuel treatment system should comprise at least one settling tank and two separators. Correct dimensioning of HFO separators is of greatest importance, and therefore the recommendations of the separator manufacturer must be closely followed. Poorly centrifuged fuel is harmful to the engine and a high content of water may also damage the fuel feed system.

Injection pumps generate pressure pulses into the fuel feed and return piping.

The fuel pipes between the feed unit and the engine must be properly clamped to rigid structures. The distance between the fixing points should be at close distance next to the engine. See chapter *Piping design, treatment and installation*.

A connection for compressed air should be provided before the engine, together with a drain from the fuel return line to the clean leakage fuel or overflow tank. With this arrangement it is possible to blow out fuel from the engine prior to maintenance work, to avoid spilling.

NOTE



In multiple engine installations, where several engines are connected to the same fuel feed circuit, it must be possible to close the fuel supply and return lines connected to the engine individually. This is a SOLAS requirement. It is further stipulated that the means of isolation shall not affect the operation of the other engines, and it shall be possible to close the fuel lines from a position that is not rendered inaccessible due to fire on any of the engines.

6.3.1 Low sulphur operation

For newbuildings expected to operate purely within SECAs, fuel and lubricating oil filling, storage, transfer, separation, and supply systems can in principle be arranged as on a traditional HFO ship.

However, if intention is to operate on different fuel qualities inside and outside SECAs it is beneficial to install double bunker tanks, settling tanks, service tanks and leak fuel tanks in order to avoid mixing incompatible fuels. Also check if flexible lube oil systems is needed, in order to avoid operation with high-sulphur fuel and too low lube oil BN.

6.3.2 Definitions Filtration term used

- **mesh size:** opening of the mesh (surface filtration), and often used as commercial name at purchase. Only approximately related to Efficiency and Beta-value. Insufficient to compare two filters from two suppliers. Good to compare two meshes of same filter model from same supplier. Totally different than micron absolute, that is always much bigger size in micron.
 - e.g. a real example: 30 micron mesh size = approx. 50 micron $\beta_{50} = 75$
- **XX micron, nominal:** commercial name of that mesh, at purchase. Not really related to filtration capability, especially when comparing different suppliers. Typically, a totally different value than XX micron, absolute.
 - e.g. a real example: 10 micron nominal ($\beta_{10} = 60\%$) = approx. 60 micron absolute.
- **XX micron, absolute:** intended here as $\beta_{xx} = 75$ ISO 16889 (similar to old $\text{exx} = 98,7\%$)
 - Beta value $\beta_{XX} = YY$: ISO name with ISO 16889 standardised test method. Weak repeatability for dust bigger than 25..45 microns.
 - Example: $\beta_{20} = 75$ means “every 75 particles 20 micron ISO dust sent, one passes”.

- Efficiency $\beta_{XX} = YY\%$: same meaning as Beta-value, but not any ISO standardised test method, hence sometimes used for particles larger than 25..45 micron.

- Example: $\beta_{20} = 98,7\%$ means “every 75 particles 20 micron non-ISO dust sent, one passes, which is 98,7% stopped.”

6.3.3 Fuel heating requirements HFO

Heating is required for:

- Bunker tanks, settling tanks, day tanks
- Pipes (trace heating)
- Separators
- Fuel feeder/booster units

To enable pumping the temperature of bunker tanks must always be maintained 5...10°C above the pour point, typically at 40...50°C. The heating coils can be designed for a temperature of 60°C.

The tank heating capacity is determined by the heat loss from the bunker tank and the desired temperature increase rate.

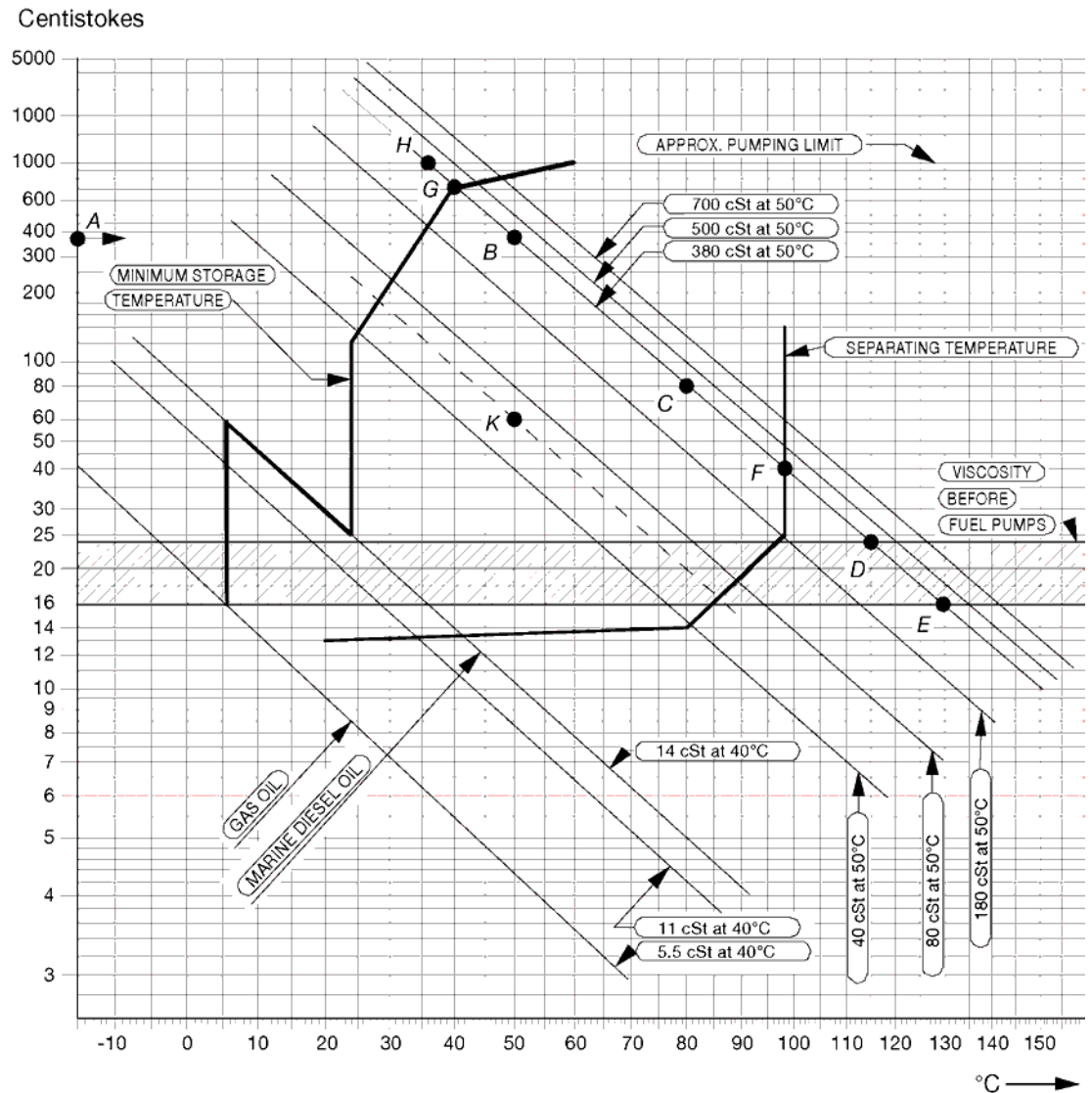

Fig 6-3 Fuel oil viscosity-temperature diagram for determining the pre-heating temperatures of fuel oils (4V92G0071b)

Example 1: A fuel oil with a viscosity of 380 cSt (A) at 50°C (B) or 80 cSt at 80°C (C) must be pre-heated to 115 - 130°C (D-E) before the fuel injection pumps, to 98°C (F) at the separator and to minimum 40°C (G) in the bunker tanks. The fuel oil may not be pumpable below 36°C (H).

To obtain temperatures for intermediate viscosities, draw a line from the known viscosity/temperature point in parallel to the nearest viscosity/temperature line in the diagram.

Example 2: Known viscosity 60 cSt at 50°C (K). The following can be read along the dotted line: viscosity at 80°C = 20 cSt, temperature at fuel injection pumps 74 - 87°C, separating temperature 86°C, minimum bunker tank temperature 28°C.

6.3.4 Fuel tanks

The fuel oil is first transferred from the bunker tanks to settling tanks for initial separation of sludge and water. After centrifuging the fuel oil is transferred to day tanks, from which fuel is supplied to the engines.

6.3.4.1 Settling tank, HFO (1T02) and MDF (1T10)

Separate settling tanks for HFO and MDF are recommended.

In case intention is to operate on low sulphur fuel it is beneficial to install double settling tanks to avoid incompatibility problems.

To ensure sufficient time for settling (water and sediment separation), the capacity of each tank should be sufficient for min. 24 hours operation at maximum fuel consumption. The tanks should be provided with internal baffles to achieve efficient settling and have a sloped bottom for proper draining. The temperature in HFO settling tanks should be maintained between 50°C and 70°C, which requires heating coils and insulation of the tank. Usually MDF settling tanks do not need heating or insulation, but the tank temperature should be in the range 20...40°C.

6.3.4.2 Day tank, HFO (1T03) and MDF (1T06)

Two day tanks for HFO are to be provided, each with a capacity sufficient for at least 8 hours operation at maximum fuel consumption. A separate tank is to be provided for MDF. The capacity of the MDF tank should ensure fuel supply for 8 hours. Settling tanks may not be used instead of day tanks.

In case intention is to operate on different fuel qualities (low sulphur fuel) it is beneficial to install double day tanks to avoid incompatibility problems.

The day tank must be designed so that accumulation of sludge near the suction pipe is prevented and the bottom of the tank should be sloped to ensure efficient draining. HFO day tanks shall be provided with heating coils and insulation. It is recommended that the viscosity is kept below 140 cSt in the day tanks. Due to risk of wax formation, fuels with a viscosity lower than 50 cSt at 50°C must be kept at a temperature higher than the viscosity would require. Continuous separation is nowadays common practice, which means that the HFO day tank temperature normally remains above 90°C. The temperature in the MDF day tank should be in the range 20...40°C. The level of the tank must ensure a positive static pressure on the suction side of the fuel feed pumps.

If black-out starting with MDF from a gravity tank is foreseen, then the tank must be located at least 15 m above the engine crankshaft.

6.3.4.3 Starting tank, MDF (1T09)

The starting tank is needed when the engine is equipped with the engine driven fuel feed pump and when the MDF day tank (1T06) cannot be located high enough, i.e. less than 1.5 meters above the engine crankshaft.

The purpose of the starting tank is to ensure that fuel oil is supplied to the engine during starting. The starting tank shall be located at least 1.5 meters above the engine crankshaft. The volume of the starting tank should be approx. 60 l.

6.3.4.4 Leak fuel tank, clean fuel (1T04)

Clean leak fuel is drained by gravity from the engine. The fuel should be collected in a separate clean leak fuel tank, from where it can be pumped to the day tank and reused without separation. The pipes from the engine to the clean leak fuel tank should be arranged continuously sloping. The tank and the pipes must be heated and insulated, unless the installation is designed for operation on MDF only.

The leak fuel piping should be fully closed to prevent dirt from entering the system.

6.3.4.5 Leak fuel tank, dirty fuel (1T07)

In normal operation no fuel should leak out from the components of the fuel system. In connection with maintenance, or due to unforeseen leaks, fuel or water may spill in the hot box of the engine. The spilled liquids are collected and drained by gravity from the engine through the dirty fuel connection.

Dirty leak fuel shall be led to a sludge tank. The tank and the pipes must be heated and insulated, unless the installation is designed for operation exclusively on MDF.

6.3.4.6 Bunker tank (1T01)

In case intention is to operate on low sulphur fuel it is beneficial to install extra bunker tanks. This to permit the ship to bunker low sulphur fuel in empty tanks anytime, even if both fuel qualities are available in other tanks.

6.3.5 Fuel treatment

6.3.5.1 Separation

Heavy fuel (residual, and mixtures of residuals and distillates) must be cleaned in an efficient centrifugal separator before it is transferred to the day tank.

Classification rules require the separator arrangement to be redundant so that required capacity is maintained with any one unit out of operation.

All recommendations from the separator manufacturer must be closely followed.

Centrifugal disc stack separators are recommended also for installations operating on MDF only, to remove water and possible contaminants. The capacity of MDF separators should be sufficient to ensure the fuel supply at maximum fuel consumption. Would a centrifugal separator be considered too expensive for a MDF installation, then it can be accepted to use coalescing type filters instead. A coalescing filter is usually installed on the suction side of the circulation pump in the fuel feed system. The filter must have a low pressure drop to avoid pump cavitation.

Separator mode of operation

The best separation efficiency is achieved when also the stand-by separator is in operation all the time, and the throughput is reduced according to actual consumption.

Separators with monitoring of cleaned fuel (without gravity disc) operating on a continuous basis can handle fuels with densities exceeding 991 kg/m³ at 15°C. In this case the main and stand-by separators should be run in parallel.

When separators with gravity disc are used, then each stand-by separator should be operated in series with another separator, so that the first separator acts as a purifier and the second as clarifier. This arrangement can be used for fuels with a density of max. 991 kg/m³ at 15°C. The separators must be of the same size.

Separation efficiency

The term Certified Flow Rate (CFR) has been introduced to express the performance of separators according to a common standard. CFR is defined as the flow rate in l/h, 30 minutes after sludge discharge, at which the separation efficiency of the separator is 85%, when using defined test oils and test particles. CFR is defined for equivalent fuel oil viscosities of 380 cSt and 700 cSt at 50°C. More information can be found in the CEN (European Committee for Standardisation) document CWA 15375:2005 (E).

The separation efficiency is measure of the separator's capability to remove specified test particles. The separation efficiency is defined as follows:

$$n = 100 \times \left(1 - \frac{C_{out}}{C_{in}} \right)$$

where:

n = separation efficiency [%]

C_{out} = number of test particles in cleaned test oil

C_{in} = number of test particles in test oil before separator

6.3.5.2 Separator unit (1N02/1N05)

Separators are usually supplied as pre-assembled units designed by the separator manufacturer.

Typically separator modules are equipped with:

- Suction strainer (1F02)
- Feed pump (1P02)
- Pre-heater (1E01)
- Sludge tank (1T05)
- Separator (1S01/1S02)
- Sludge pump
- Control cabinets including motor starters and monitoring

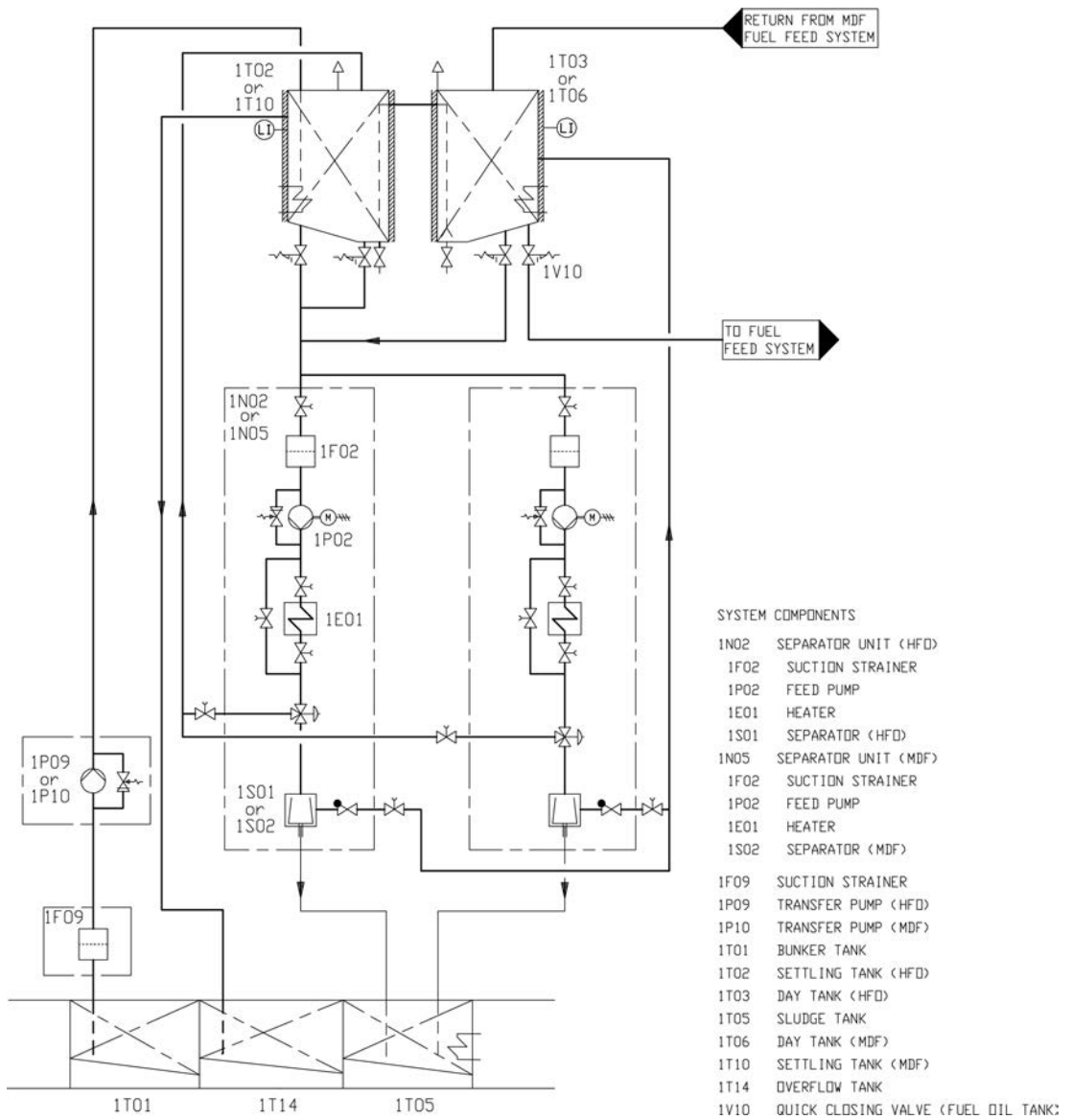

Fig 6-4 Fuel transfer and separating system (V76F6626G)

6.3.5.3 Separator feed pumps (1P02)

Feed pumps should be dimensioned for the actual fuel quality and recommended throughput of the separator. The pump should be protected by a suction strainer (mesh size about 0.5 mm)

An approved system for control of the fuel feed rate to the separator is required.

Design data:	HFO	MDF
Design pressure	0.5 MPa (5 bar)	0.5 MPa (5 bar)
Design temperature	100°C	50°C
Viscosity for dimensioning electric motor	1000 cSt	100 cSt

6.3.5.4 Separator pre-heater (1E01)

The pre-heater is dimensioned according to the feed pump capacity and a given settling tank temperature.

The surface temperature in the heater must not be too high in order to avoid cracking of the fuel. The temperature control must be able to maintain the fuel temperature within $\pm 2^\circ\text{C}$.

Recommended fuel temperature after the heater depends on the viscosity, but it is typically 98°C for HFO and $20\text{...}40^\circ\text{C}$ for MDF. The optimum operating temperature is defined by the separator manufacturer.

The required minimum capacity of the heater is:

$$P = \frac{Q \times \Delta T}{1700}$$

where:

P = heater capacity [kW]

Q = capacity of the separator feed pump [l/h]

ΔT = temperature rise in heater [$^\circ\text{C}$]

For heavy fuels $\Delta T = 48^\circ\text{C}$ can be used, i.e. a settling tank temperature of 50°C . Fuels having a viscosity higher than 5 cSt at 50°C require pre-heating before the separator.

The heaters to be provided with safety valves and drain pipes to a leakage tank (so that the possible leakage can be detected).

6.3.5.5 Separator (1S01/1S02)

Based on a separation time of 23 or 23.5 h/day, the service throughput Q [l/h] of the separator can be estimated with the formula:

$$Q = \frac{P \times b \times 24[\text{h}]}{\rho \times t}$$

where:

P = max. continuous rating of the diesel engine(s) [kW]

b = specific fuel consumption + 15% safety margin [g/kWh]

ρ = density of the fuel [kg/m^3]

t = daily separating time for self cleaning separator [h] (usually = 23 h or 23.5 h)

The flow rates recommended for the separator and the grade of fuel must not be exceeded. The lower the flow rate the better the separation efficiency.

Sample valves must be placed before and after the separator.

6.3.5.6 MDF separator in HFO installations (1S02)

A separator for MDF is recommended also for installations operating primarily on HFO. The MDF separator can be a smaller size dedicated MDF separator, or a stand-by HFO separator used for MDF.

6.3.5.7 Sludge tank (1T05)

The sludge tank should be located directly beneath the separators, or as close as possible below the separators, unless it is integrated in the separator unit. The sludge pipe must be continuously falling.

6.3.6 Fuel feed system - MDF installations

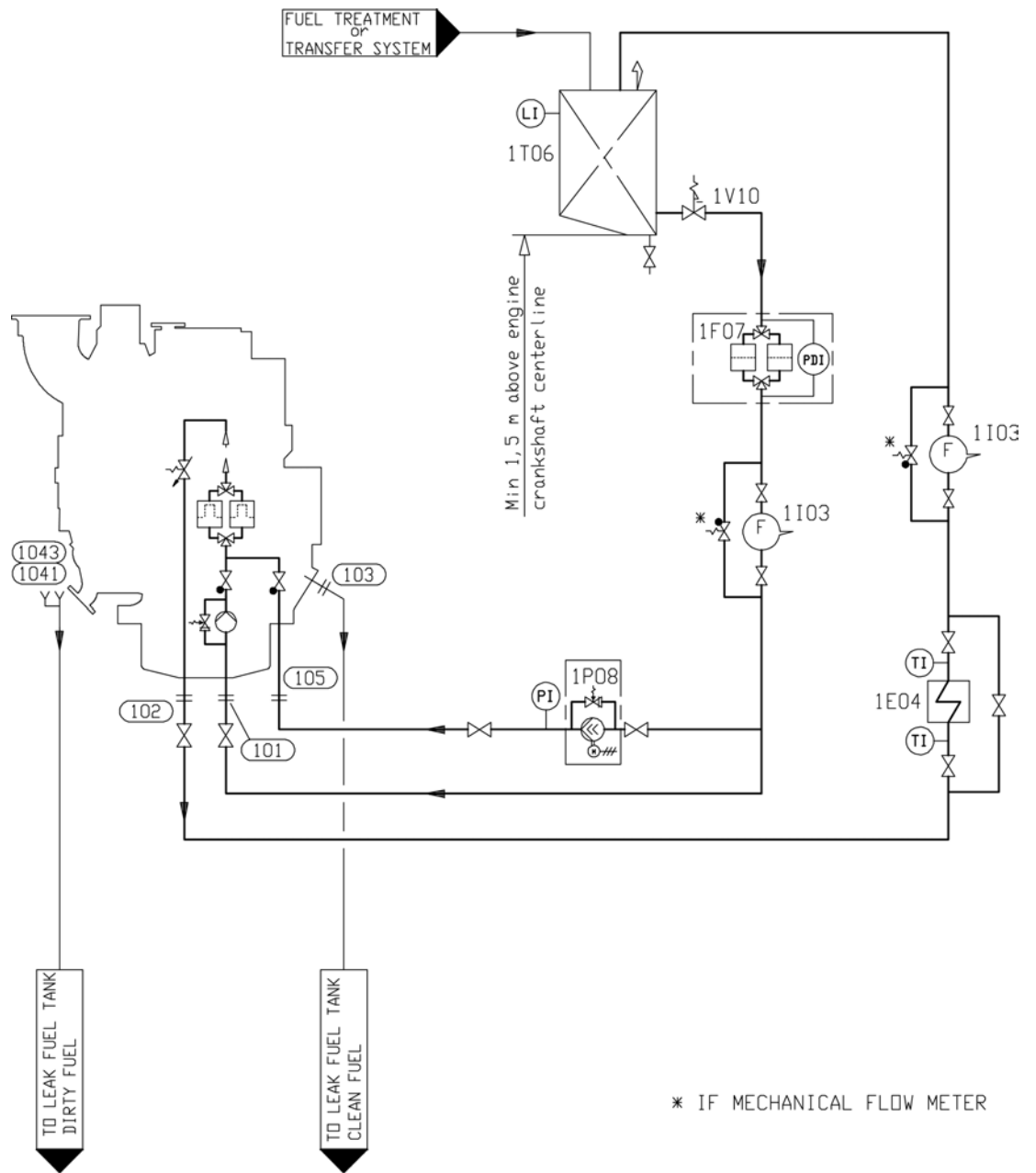

Fig 6-5 Fuel feed system, single main engine (DAAE003608E)

Pipe connections		Size
101	Fuel inlet	OD28
102	Fuel outlet	OD28
103	Leak fuel drain, clean fuel	OD18
1041	Leak fuel drain, dirty fuel free end	OD22
1043	Leak fuel drain, dirty fuel FW-end	OD18
105	Fuel stand-by connection	OD22

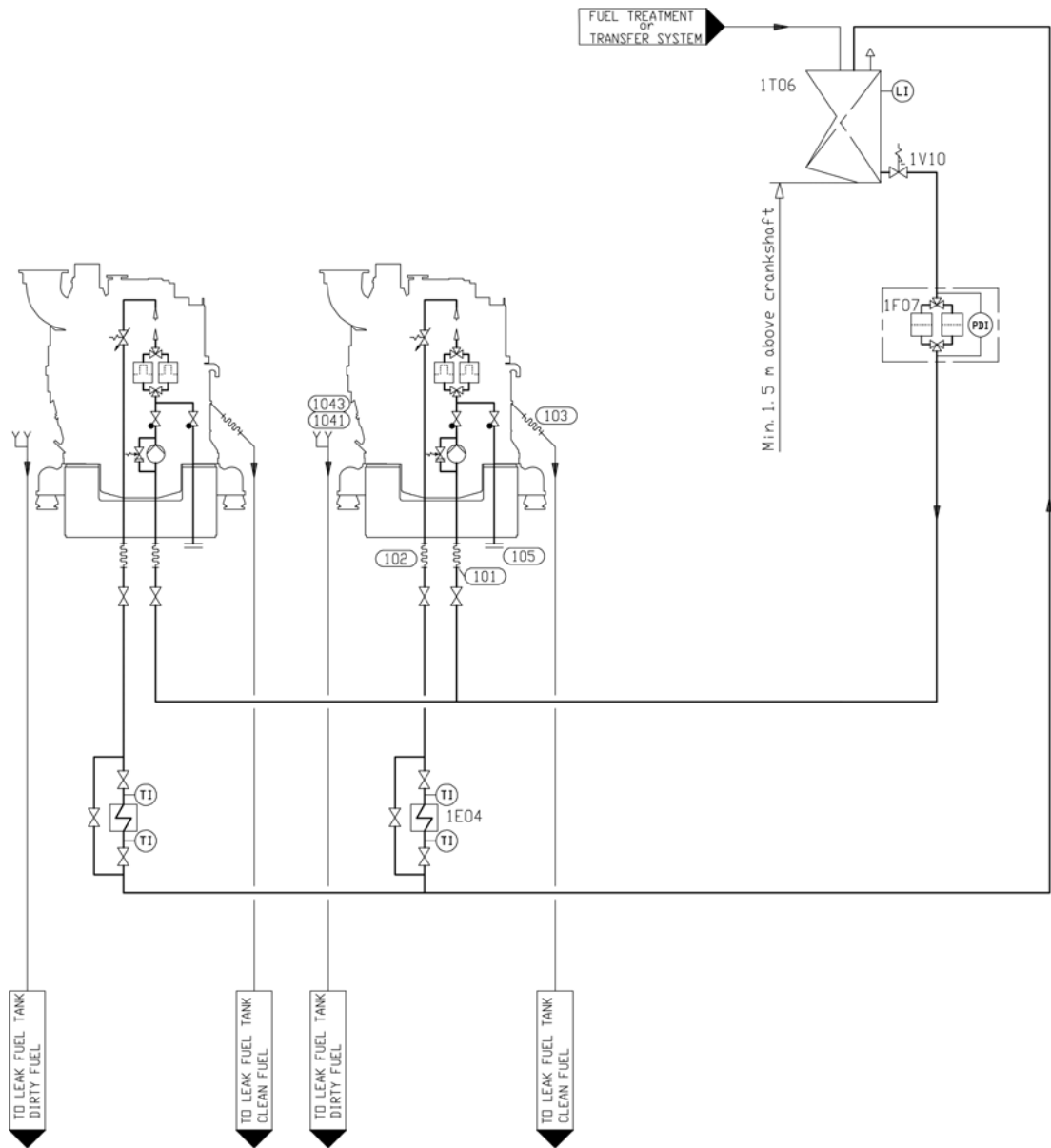

Fig 6-6 Fuel feed system, multiple engines (DAAF064961A)

Pipe connections		Size
101	Fuel inlet	OD28
102	Fuel outlet	OD28
103	Leak fuel drain, clean fuel	OD18
1041	Leak fuel drain, dirty fuel flywheel end	OD22
1043	Leak fuel drain, dirty fuel free end	OD18
105	Fuel stand-by connection	PLUG

If the engines are to be operated on MDF only, heating of the fuel is normally not necessary. In such case it is sufficient to install the equipment listed below. Some of the equipment listed below is also to be installed in the MDF part of a HFO fuel oil system.

6.3.6.1 Circulation pump, MDF (1P03)

The circulation pump maintains the pressure at the injection pumps and circulates the fuel in the system. It is recommended to use a screw pump as circulation pump. A suction strainer with a fineness of 0.5 mm should be installed before each pump. There must be a positive static pressure of about 30 kPa on the suction side of the pump.

Design data:	
Capacity	5 x the total consumption of the connected engines
Design pressure	1.6 MPa (16 bar)
Max. total pressure (safety valve)	1.0 MPa (10 bar)
Nominal pressure	see chapter "Technical Data"
Design temperature	50°C
Viscosity for dimensioning of electric motor	90 cSt

6.3.6.2 Stand-by pump, MDF (1P08)

The stand-by pump is required in case of a single main engine equipped with an engine driven pump. It is recommended to use a screw pump as stand-by pump. The pump should be placed so that a positive static pressure of about 30 kPa is obtained on the suction side of the pump.

Design data:

Capacity	5 x the total consumption of the connected engine
Design pressure	1.6 MPa (16 bar)
Max. total pressure (safety valve)	1.2 MPa (12 bar)
Design temperature	50°C
Viscosity for dimensioning of electric motor	90 cSt

6.3.6.3 Flow meter, MDF (1I03)

If the return fuel from the engine is conducted to a return fuel tank instead of the day tank, one consumption meter is sufficient for monitoring of the fuel consumption, provided that the meter is installed in the feed line from the day tank (before the return fuel tank). A fuel oil cooler is usually required with a return fuel tank.

The total resistance of the flow meter and the suction strainer must be small enough to ensure a positive static pressure of about 30 kPa on the suction side of the circulation pump.

There should be a by-pass line around the consumption meter, which opens automatically in case of excessive pressure drop.

6.3.6.4 Fine filter, MDF (1F05)

The fuel oil fine filter is a full flow duplex type filter with steel net. This filter must be installed as near the engine as possible.

The diameter of the pipe between the fine filter and the engine should be the same as the diameter before the filters.

Design data:

Fuel viscosity	according to fuel specifications
Design temperature	50°C
Design flow	Larger than feed/circulation pump capacity
Design pressure	1.6 MPa (16 bar)
Fineness	25 µm (absolute mesh size)

Maximum permitted pressure drops at 14 cSt:

- clean filter	20 kPa (0.2 bar)
- alarm	80 kPa (0.8 bar)

6.3.6.5 Pressure control valve, MDF (1V02)

The pressure control valve is installed when the installation includes a feeder/booster unit for HFO and there is a return line from the engine to the MDF day tank. The purpose of the valve is to increase the pressure in the return line so that the required pressure at the engine is achieved.

Design data:

Capacity	Equal to circulation pump
Design temperature	50°C
Design pressure	1.6 MPa (16 bar)
Set point	0.4...0.7 MPa (4...7 bar)

6.3.6.6 MDF cooler (1E04)

The fuel viscosity may not drop below the minimum value stated in *Technical data*. When operating on MDF, the practical consequence is that the fuel oil inlet temperature must be kept below 45°C. Very light fuel grades may require even lower temperature.

Sustained operation on MDF usually requires a fuel oil cooler. The cooler is to be installed in the return line after the engine(s). LT-water is normally used as cooling medium.

If MDF viscosity in day tank drops below stated minimum viscosity limit then it is recommended to install an MDF cooler into the engine fuel supply line in order to have reliable viscosity control.

Design data:

Heat to be dissipated	1 kW/cyl
Max. pressure drop, fuel oil	80 kPa (0.8 bar)
Max. pressure drop, water	60 kPa (0.6 bar)
Margin (heat rate, fouling)	min. 15%
Design temperature MDF/HFO installation	50/150°C

6.3.6.7 Return fuel tank (1T13)

The return fuel tank shall be equipped with a vent valve needed for the vent pipe to the MDF day tank. The volume of the return fuel tank should be at least 100 l.

6.3.6.8 Black out start

Diesel generators serving as the main source of electrical power must be able to resume their operation in a black out situation by means of stored energy. Depending on system design and classification regulations, it may in some cases be permissible to use the emergency generator. HFO engines without engine driven fuel feed pump can reach sufficient fuel pressure to enable black out start by means of:

- A gravity tank located min. 15 m above the crankshaft
- A pneumatically driven fuel feed pump (1P11)
- An electrically driven fuel feed pump (1P11) powered by an emergency power source

6.3.7 Fuel feed system - HFO installations

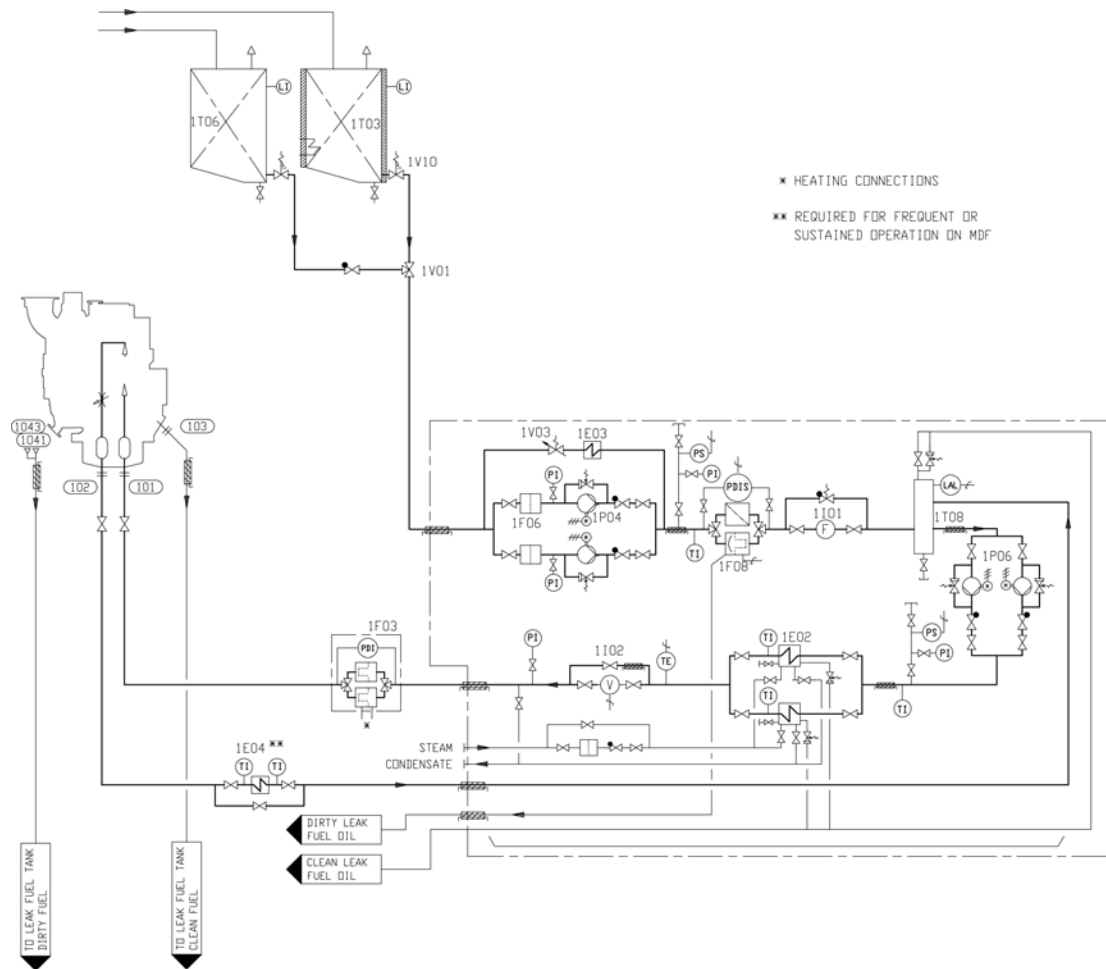

Fig 6-7 Fuel oil system (HFO), single main engine (DAAF437836)

System components			
1E02	Heater (booster unit)	1P06	Circulation pump (booster unit)
1E03	Cooler (booster unit)	1T03	Day tank (HFO)
1E04	Cooler (MDF)	1T06	Day tank (MDF)
1F03	Safety filter (HFO)	1T08	De-aeration tank (booster unit)
1F06	Suction filter (booster unit)	1V01	Change over valve
1F08	Automatic filter (booster unit)	1V03	Pressure control valve (booster unit)
1I01	Flow meter (booster unit)	1V10	Quick closing valve (fuel oil tank)
1I02	Viscosity meter (booster unit)		
1P04	Fuel feed pump (booster unit)		

Pipe connections		Size
101	Fuel inlet	OD18
102	Fuel outlet	OD18
103	Leak fuel drain, clean fuel	OD18
1041	Leak fuel drain, dirty fuel free end	OD22
1043	Leak fuel drain, dirty fuel flywheel end	OD18

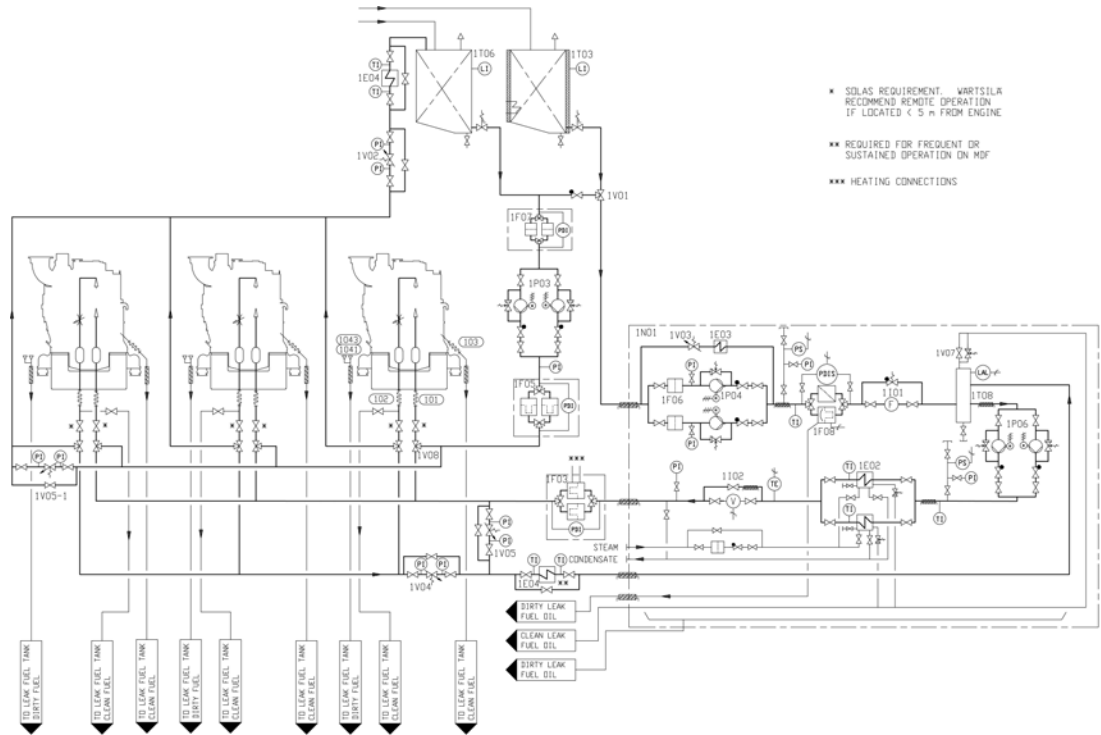

Fig 6-8 Example of fuel oil system (HFO), multiple engine installation (V76F6656H)

System components			
1E02	Heater (booster unit)	1P06	Circulation pump (booster unit)
1E03	Cooler (booster unit)	1T03	Day tank (HFO)
1E04	Cooler (MDF)	1T06	Day tank (MDF)
1F03	Safety filter (HFO)	1T08	De-aeration tank (booster unit)
1F05	Fine filter (MDF)	1V01	Change over valve
1F06	Suction filter (booster unit)	1V02	Pressure control valve (MDF)
1F07	Suction strainer (MDF)	1V03	Pressure control valve (booster unit)
1F08	Automatic filter (booster unit)	1V04	Pressure control valve (HFO)
1I01	Flow meter (booster unit)	1V05	Overflow valve (HFO/MDF)
1I02	Viscosity meter (booster unit)	1V05-1	Overflow valve (HFO/MDF)
1N01	Feeder/Booster unit	1V07	Venting valve (booster unit)
1P03	Circulation pump (MDF)	1V08	Change over valve
1P04	Fuel feed pump (booster unit)		

Pipe connections		Size
101	Fuel inlet	OD18
102	Fuel outlet	OD18
103	Leak fuel drain, clean fuel	OD18
1041	Leak fuel drain, dirty fuel free end	OD22
1043	Leak fuel drain, dirty fuel flywheel end	OD18

HFO pipes shall be properly insulated. If the viscosity of the fuel is 180 cSt/50°C or higher, the pipes must be equipped with trace heating. It shall be possible to shut off the heating of the pipes when operating on MDF (trace heating to be grouped logically).

6.3.7.1 Starting and stopping

The engine can be started and stopped on HFO provided that the engine and the fuel system are pre-heated to operating temperature. The fuel must be continuously circulated also through a stopped engine in order to maintain the operating temperature. Changeover to MDF for start and stop is not required.

Prior to overhaul or shutdown of the external system the engine fuel system shall be flushed and filled with MDF.

6.3.7.2 Changeover from HFO to MDF

The control sequence and the equipment for changing fuel during operation must ensure a smooth change in fuel temperature and viscosity. When MDF is fed through the HFO feeder/booster unit, the volume in the system is sufficient to ensure a reasonably smooth transfer.

When there are separate circulating pumps for MDF, then the fuel change should be performed with the HFO feeder/booster unit before switching over to the MDF circulating pumps. As mentioned earlier, sustained operation on MDF usually requires a fuel oil cooler. The viscosity at the engine shall not drop below the minimum limit stated in chapter *Technical data*.

6.3.7.3 Changeover to low sulphur fuel

- Fuel system should allow slow, controlled change in fuel temperature in order to avoid thermal shock in the injection pumps. The recommended fuel temperature change over rate at switching is maximum 2 °C / min.
- Check compatibility when using mixed fuels (clogging filters, separators etc). Wärtsilä 4-stroke engines are normally not sensitive for fuel lubricity and additives are not necessarily needed.
- HFO engines starting to alternate between HFO and MDF or LSMDF can typically continue with the same lubricant as before. Nimonic exhaust valves should be used to avoid hot corrosion.
- HFO engines starting to operate continuously on LSHFO can continue using lubricating oil with a BN of at least 30.
- Engines starting to operate continuously on MDF or LSMDF are recommended to start using lubricating oil with lower BN 10-20. Exhaust valves with stellite facing should be used.
- BN monitoring of lubricating oil should be established in order to prevent operating with too low BN (increased risk for corrosion).

6.3.7.4 Number of engines in the same system

When the fuel feed unit serves Wärtsilä 20 engines only, maximum three engines should be connected to the same fuel feed circuit, unless individual circulating pumps before each engine are installed.

Main engines and auxiliary engines should preferably have separate fuel feed units. Individual circulating pumps or other special arrangements are often required to have main engines and auxiliary engines in the same fuel feed circuit. Regardless of special arrangements it is not recommended to supply more than maximum two main engines and two auxiliary engines, or one main engine and three auxiliary engines from the same fuel feed unit.

In addition the following guidelines apply:

- Twin screw vessels with two engines should have a separate fuel feed circuit for each propeller shaft.
- Twin screw vessels with four engines should have the engines on the same shaft connected to different fuel feed circuits. One engine from each shaft can be connected to the same circuit.

6.3.7.5 Feeder/booster unit (1N01)

A completely assembled feeder/booster unit can be supplied. This unit comprises the following equipment:

- Two suction strainers
- Two fuel feed pumps of screw type, equipped with built-on safety valves and electric motors
- One pressure control/overflow valve
- One pressurized de-aeration tank, equipped with a level switch operated vent valve
- Two circulating pumps, same type as the fuel feed pumps
- Two heaters, steam, electric or thermal oil (one heater in operation, the other as spare)
- One automatic back-flushing filter with by-pass filter
- One viscosimeter for control of the heaters
- One control valve for steam or thermal oil heaters, a control cabinet for electric heaters
- One temperature sensor for emergency control of the heaters
- One control cabinet including starters for pumps
- One alarm panel

The above equipment is built on a steel frame, which can be welded or bolted to its foundation in the ship. The unit has all internal wiring and piping fully assembled. All HFO pipes are insulated and provided with trace heating.

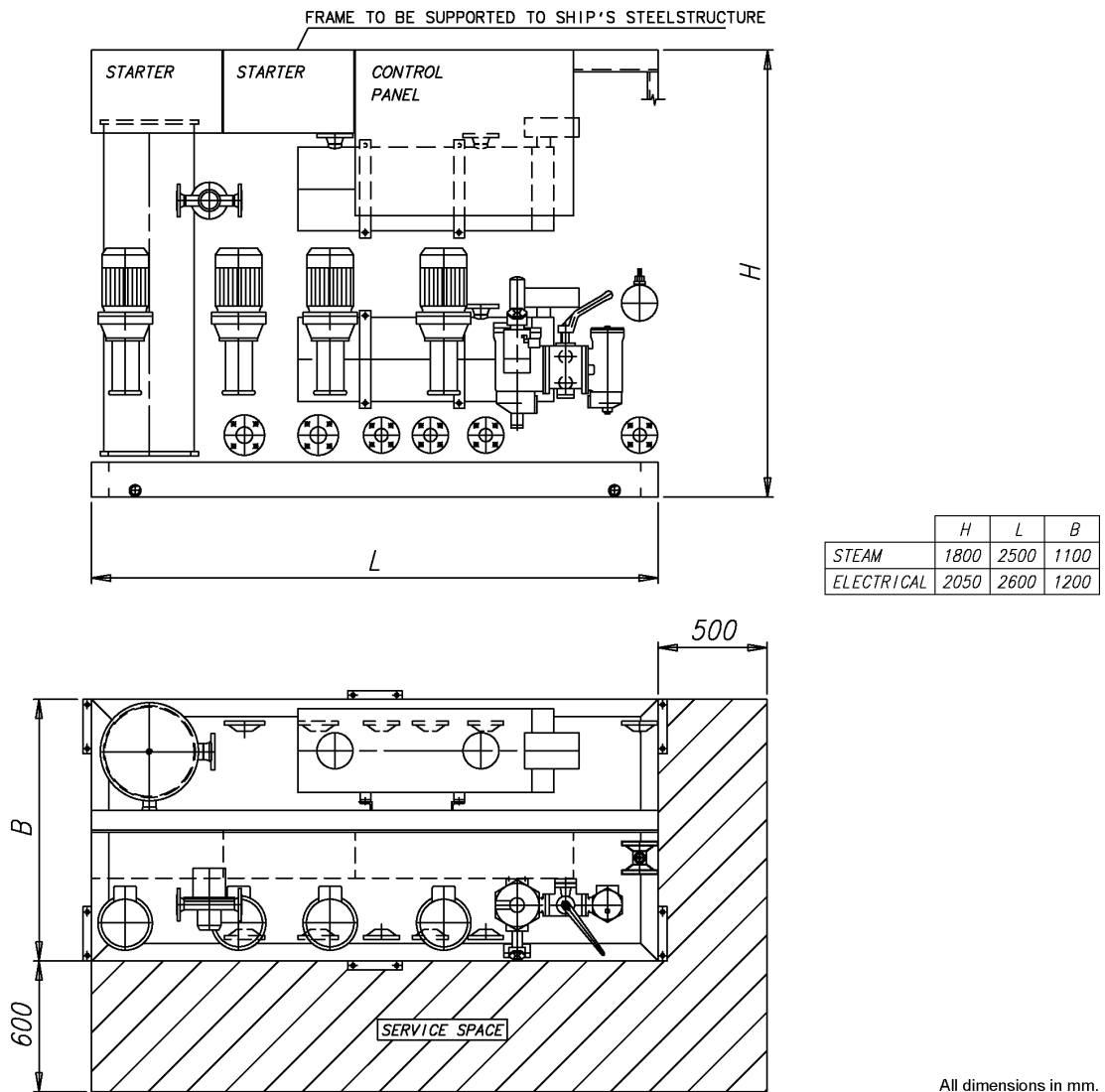

Fig 6-9 Feeder/booster unit, example (DAAE006659)

Fuel feed pump, booster unit (1P04)

The feed pump maintains the pressure in the fuel feed system. It is recommended to use a screw pump as feed pump. The capacity of the feed pump must be sufficient to prevent pressure drop during flushing of the automatic filter.

A suction strainer with a fineness of 0.5 mm should be installed before each pump. There must be a positive static pressure of about 30 kPa on the suction side of the pump.

Design data:

Capacity	Total consumption of the connected engines added with the flush quantity of the automatic filter (1F08) and 15% margin.
Design pressure	1.6 MPa (16 bar)
Max. total pressure (safety valve)	0.7 MPa (7 bar)
Design temperature	100°C
Viscosity for dimensioning of electric motor	1000 cSt

Pressure control valve, booster unit (1V03)

The pressure control valve in the feeder/booster unit maintains the pressure in the de-aeration tank by directing the surplus flow to the suction side of the feed pump.

Design data:

Capacity	Equal to feed pump
Design pressure	1.6 MPa (16 bar)
Design temperature	100°C
Set-point	0.3...0.5 MPa (3...5 bar)

Automatic filter, booster unit (1F08)

It is recommended to select an automatic filter with a manually cleaned filter in the bypass line. The automatic filter must be installed before the heater, between the feed pump and the de-aeration tank, and it should be equipped with a heating jacket. Overheating (temperature exceeding 100°C) is however to be prevented, and it must be possible to switch off the heating for operation on MDF.

Design data:

Fuel viscosity	According to fuel specification
Design temperature	100°C
Preheating	If fuel viscosity is higher than 25 cSt/100°C
Design flow	Equal to feed pump capacity
Design pressure	1.6 MPa (16 bar)
Fineness:	
- automatic filter	35 µm absolute ($\beta_{50} = 75$, $\beta_{35} = 2$, ISO 16889)
- by-pass filter	35 µm absolute ($\beta_{50} = 75$, $\beta_{35} = 2$, ISO 16889)
Maximum permitted pressure drops at 14 cSt:	
- clean filter	20 kPa (0.2 bar)
- alarm	80 kPa (0.8 bar)

Flow meter, booster unit (1I01)

If a fuel consumption meter is required, it should be fitted between the feed pumps and the de-aeration tank. When it is desired to monitor the fuel consumption of individual engines in a multiple engine installation, two flow meters per engine are to be installed: one in the feed line and one in the return line of each engine.

There should be a by-pass line around the consumption meter, which opens automatically in case of excessive pressure drop.

If the consumption meter is provided with a prefilter, an alarm for high pressure difference across the filter is recommended.

De-aeration tank, booster unit (1T08)

It shall be equipped with a low level alarm switch and a vent valve. The vent pipe should, if possible, be led downwards, e.g. to the overflow tank. The tank must be insulated and equipped with a heating coil. The volume of the tank should be at least 100 l.

Circulation pump, booster unit (1P06)

The purpose of this pump is to circulate the fuel in the system and to maintain the required pressure at the injection pumps, which is stated in the chapter *Technical data*. By circulating the fuel in the system it also maintains correct viscosity, and keeps the piping and the injection pumps at operating temperature.

Design data:

Capacity	5 x the total consumption of the connected engines
Design pressure	1.6 MPa (16 bar)
Max. total pressure (safety valve)	1.0 MPa (10 bar)
Design temperature	150°C
Viscosity for dimensioning of electric motor	500 cSt

Heater, booster unit (1E02)

The heater must be able to maintain a fuel viscosity of 14 cSt at maximum fuel consumption, with fuel of the specified grade and a given day tank temperature (required viscosity at injection pumps stated in *Technical data*). When operating on high viscosity fuels, the fuel temperature at the engine inlet may not exceed 135°C however.

The power of the heater is to be controlled by a viscosimeter. The set-point of the viscosimeter shall be somewhat lower than the required viscosity at the injection pumps to compensate for heat losses in the pipes. A thermostat should be fitted as a backup to the viscosity control.

To avoid cracking of the fuel the surface temperature in the heater must not be too high. The heat transfer rate in relation to the surface area must not exceed 1.5 W/cm².

The required heater capacity can be estimated with the following formula:

$$P = \frac{Q \times \Delta T}{1700}$$

where:

P = heater capacity (kW)

Q = total fuel consumption at full output + 15% margin [l/h]

ΔT = temperature rise in heater [°C]

Viscosimeter, booster unit (1I02)

The heater is to be controlled by a viscosimeter. The viscosimeter should be of a design that can withstand the pressure peaks caused by the injection pumps of the diesel engine.

Design data:

Operating range	0...50 cSt
Design temperature	180°C
Design pressure	4 MPa (40 bar)

6.3.7.6 Safety filter (1F03)

The safety filter is a full flow duplex type filter with steel net. This safety filter must be installed as close as possible to the engines. The safety filter should be equipped with a heating jacket. In multiple engine installations it is possible to have a one common safety filter for all engines.

The diameter of the pipe between the safety filter and the engine should be the same as between the feeder/booster unit and the safety filter.

Design data:

Fuel viscosity	according to fuel specification
Design temperature	150°C
Design flow	Equal to circulation pump capacity
Design pressure	1.6 MPa (16 bar)
Fineness	37 µm (absolute mesh size)

Maximum permitted pressure drops at 14 cSt:

- clean filter	20 kPa (0.2 bar)
- alarm	80 kPa (0.8 bar)

6.3.7.7 Overflow valve, HFO (1V05)

When several engines are connected to the same feeder/booster unit an overflow valve is needed between the feed line and the return line. The overflow valve limits the maximum pressure in the feed line, when the fuel lines to a parallel engine are closed for maintenance purposes.

The overflow valve should be dimensioned to secure a stable pressure over the whole operating range.

Design data:

Capacity	Equal to circulation pump (1P06)
Design pressure	1.6 MPa (16 bar)
Design temperature	150°C
Set-point (Δp)	0.1...0.2 MPa (1...2 bar)

6.3.7.8 Pressure control valve (1V04)

The pressure control valve increases the pressure in the return line so that the required pressure at the engine is achieved. This valve is needed in installations where the engine is equipped with an adjustable throttle valve in the return fuel line of the engine.

The adjustment of the adjustable throttle valve on the engine should be carried out after the pressure control valve (1V04) has been adjusted. The adjustment must be tested in different loading situations including the cases with one or more of the engines being in stand-by mode. If the main engine is connected to the same feeder/booster unit the circulation/temperatures must also be checked with and without the main engine being in operation.

6.3.8 Flushing

The external piping system must be thoroughly flushed before the engines are connected and fuel is circulated through the engines. The piping system must have provisions for installation of a temporary flushing filter.

The fuel pipes at the engine (connections 101 and 102) are disconnected and the supply and return lines are connected with a temporary pipe or hose on the installation side. All filter inserts are removed, except in the flushing filter of course. The automatic filter and the viscosimeter should be bypassed to prevent damage. The fineness of the flushing filter should be 6 µm or finer.

7. Lubricating Oil System

7.1 Lubricating oil requirements

7.1.1 Engine lubricating oil

The lubricating oil must be of viscosity class SAE 40 and have a viscosity index (VI) of minimum 95. The lubricating oil alkalinity (BN) is tied to the fuel grade, as shown in the table below. BN is an abbreviation of Base Number. The value indicates milligrams KOH per gram of oil.

Table 7-1 Fuel standards and lubricating oil requirements

Category	Fuel standard		Lubricating oil BN	Fuel S content, [% m/m]
A	ASTM D 975-01, BS MA 100: 1996 CIMAC 2003 ISO 8217:2017(E)	GRADE NO. 1-D, 2-D, 4-D DMX, DMA, DMB DX, DA, DB ISO-F-DMX - DMB	10...30	< 0.4
B	ASTM D 975-01 BS MA 100: 1996 CIMAC 2003 ISO 8217:2017(E)	GRADE NO. 1-D, 2-D, 4-D DMX, DMA, DMB DX, DA, DB ISO-F-DMB	15...30	0.4 - 2.0
C	ASTM D 975-01, ASTM D 396-04, BS MA 100: 1996 CIMAC 2003 ISO 8217:2017(E)	GRADE NO. 4-D GRADE NO. 5-6 DMC, RMA10-RMK55 DC, A30-K700 RMA 10-RMK 700	30...55	≤ 4.5
F	LIQUID BIO FUEL (LBF)		10...20	≤ 0.05

BN 50-55 lubricants are to be selected in the first place for operation on HFO. BN 40 lubricants can also be used with HFO provided that the sulphur content of the fuel is relatively low, and the BN remains above the condemning limit for acceptable oil change intervals. BN 30 lubricating oils should be used together with HFO only in special cases; for example in SCR (Selective Catalytic Reduction) installations, if better total economy can be achieved despite shorter oil change intervals. Lower BN may have a positive influence on the lifetime of the SCR catalyst.

Different oil brands may not be blended, unless it is approved by the oil suppliers. Blending of different oils must also be validated by Wärtsilä, if the engine is still under warranty.

An updated list of validated lubricating oils is supplied for every installation. Please refer to Service Bulletin WS15S475.

7.1.2 Oil in speed governor or actuator

An oil of viscosity class SAE 30 or SAE 40 is acceptable in normal operating conditions. Usually the same oil as in the engine can be used. At low ambient temperatures it may be necessary to use a multigrade oil (e.g. SAE 5W-40) to ensure proper operation during start-up with cold oil.

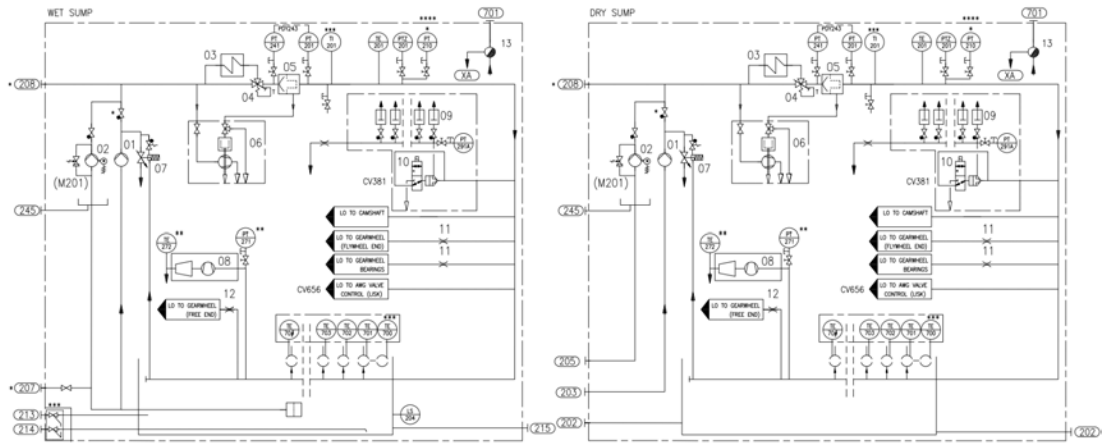

Fig 7-2 Internal lubricating oil system (TC in free end - DAAF395501E) - UNIC C2 & UNIC 2.0

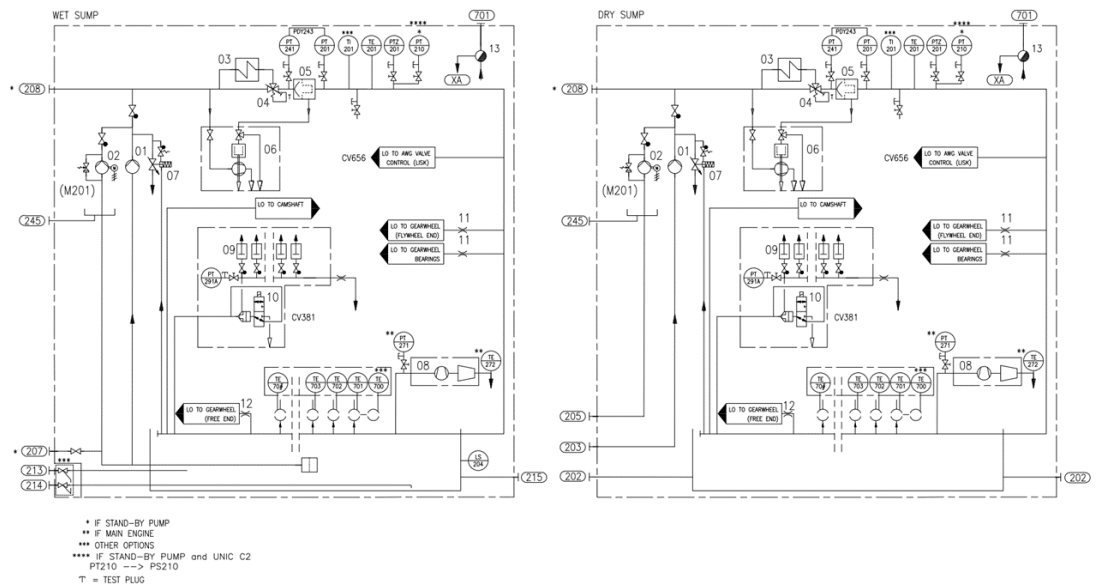

Fig 7-3 Internal lubricating oil system (TC in flywheel end - DAAF395506E) - UNIC C2 & UNIC 2.0

Table 7-3

System components:			
01	Lubricating oil main pump	07	Pressure control valve
02	Prelubricating oil pump (M201)	08	Turbocharger
03	Lubricating oil cooler	09	Guide block for VIC
04	Thermostatic valve	10	ON/OFF Control valve for VIC CV381
05	Automatic filter	11	Lube oil nozzle for gearwheel lubrication (flywheel end)
06	Centrifugal filter	12	Lube oil nozzle for gearwheel lubrication (free end)
		13	Crankcase vent pipe

Sensors and indicators:			
PT201	Lubricating oil pressure, engine inlet	TE201	Lubricating oil temp., engine inlet
PTZ201	Lubricating oil pressure, engine inlet	***T1201	Lubricating oil temp., engine inlet (if ME)

Sensors and indicators:			
CV656	Airwaste gate control	CV381	VIC control valve
PT241	Lube oil pressure, filter inlet	**TE272	Lubricating oil temp., TC outlet (if ME)
**PT271	Lubricating oil pressure, TC inlet (if ME)	TE70#	Main bearing temperature
PT291A	Control oil pressure after VIC valve	LS204	Lubricating oil low level, wet sump
PDY243	Lube oil filter pressure difference	*PT210	Lubricating oil pressure, stand-by pump
***PS210	Lube oil stand-by pump start		

Pipe connections:		Size
202	Lubricating oil outlet (from oil sump)	DN100
203	Lubricating oil to engine driven pump	DN100
205	Lubricating oil to priming pump	DN32
*207	Lubricating oil to electric driven pump	DN100
*208	Lubricating oil from electric driven pump	DN80
213	Lubricating oil from separator and filling	DN32
214	Lubricating oil to separator and drain	DN32
215	Lube oil filling	M48*2
245	Priming pump lubrication drain	TBA
701	Crankcase air vent	DN65
XA	Crankcase oil mist drain	TBA

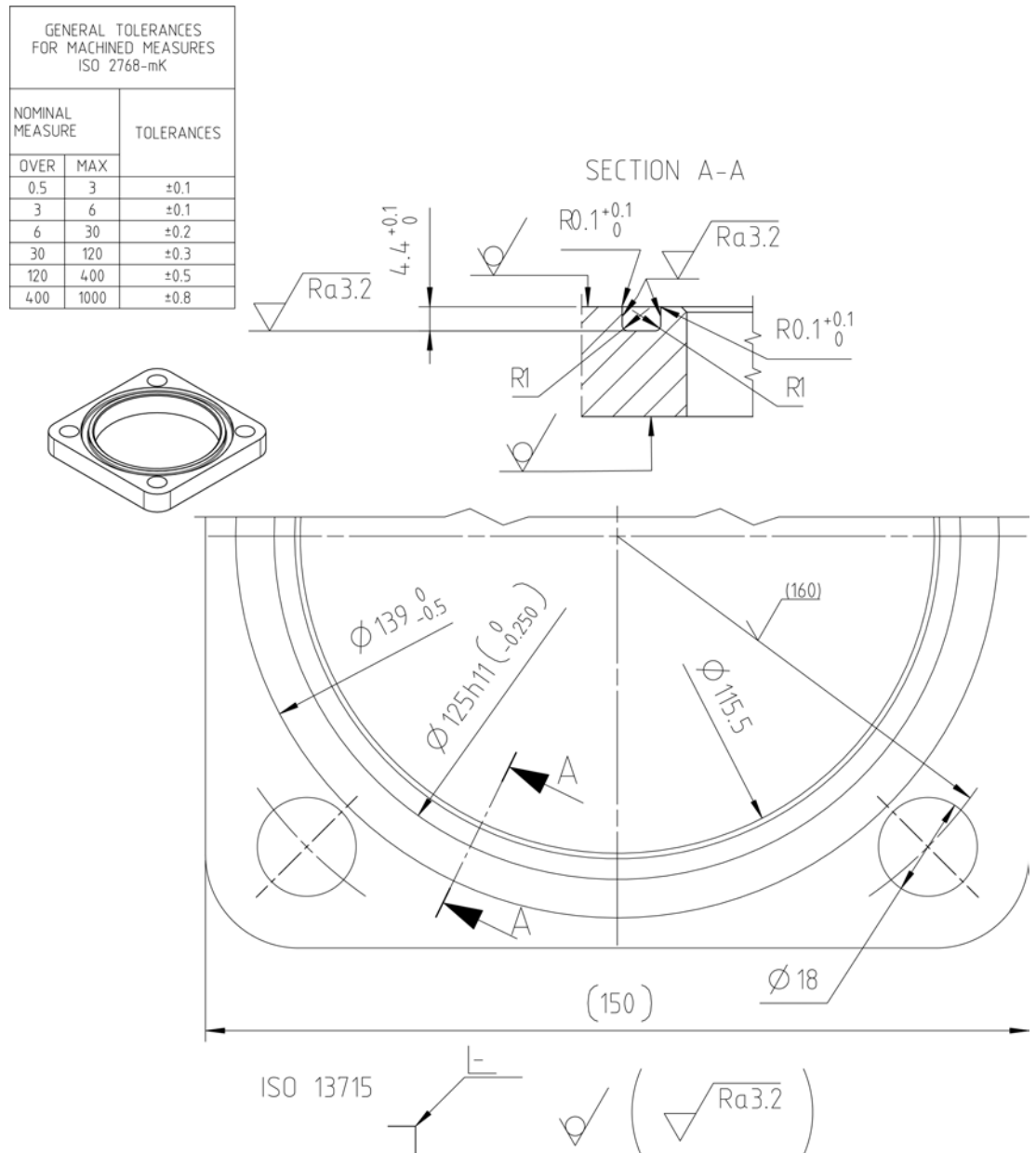

Fig 7-4 Flange for connections 202, 203, dry sump (V32A0506C)

The lubricating oil sump is of wet sump type for auxiliary and diesel-electric engines. Dry sump is recommended for main engines operating on HFO. The dry sump type has two oil outlets at each end of the engine. Two of the outlets shall be connected to the system oil tank.

The direct driven lubricating oil pump is of gear type and equipped with a pressure control valve. The pump is dimensioned to provide sufficient flow even at low speeds. A stand-by pump connection is available as option. Concerning suction height, flow rate and pressure of the pump, see *Technical data*.

The pre-lubricating pump is an electric motor driven gear pump equipped with a safety valve. The pump should always be running, when the engine is stopped. Concerning suction height, flow rate and pressure of the pump, see *Technical data*.

The lubricating oil module built on the engine consists of the lubricating oil cooler, thermostatic valve and automatic filter.

The centrifugal filter is installed to clean the back-flushing oil from the automatic filter.

7.3 External lubricating oil system

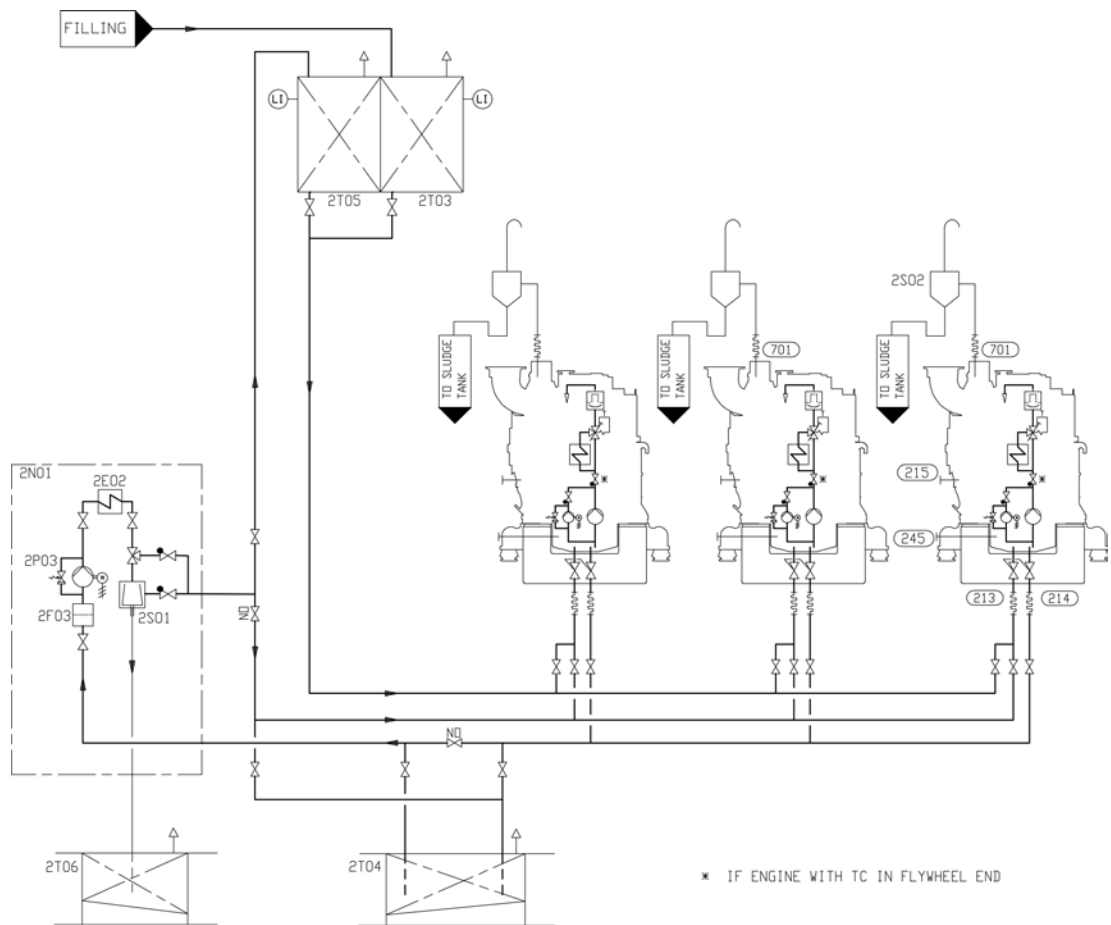
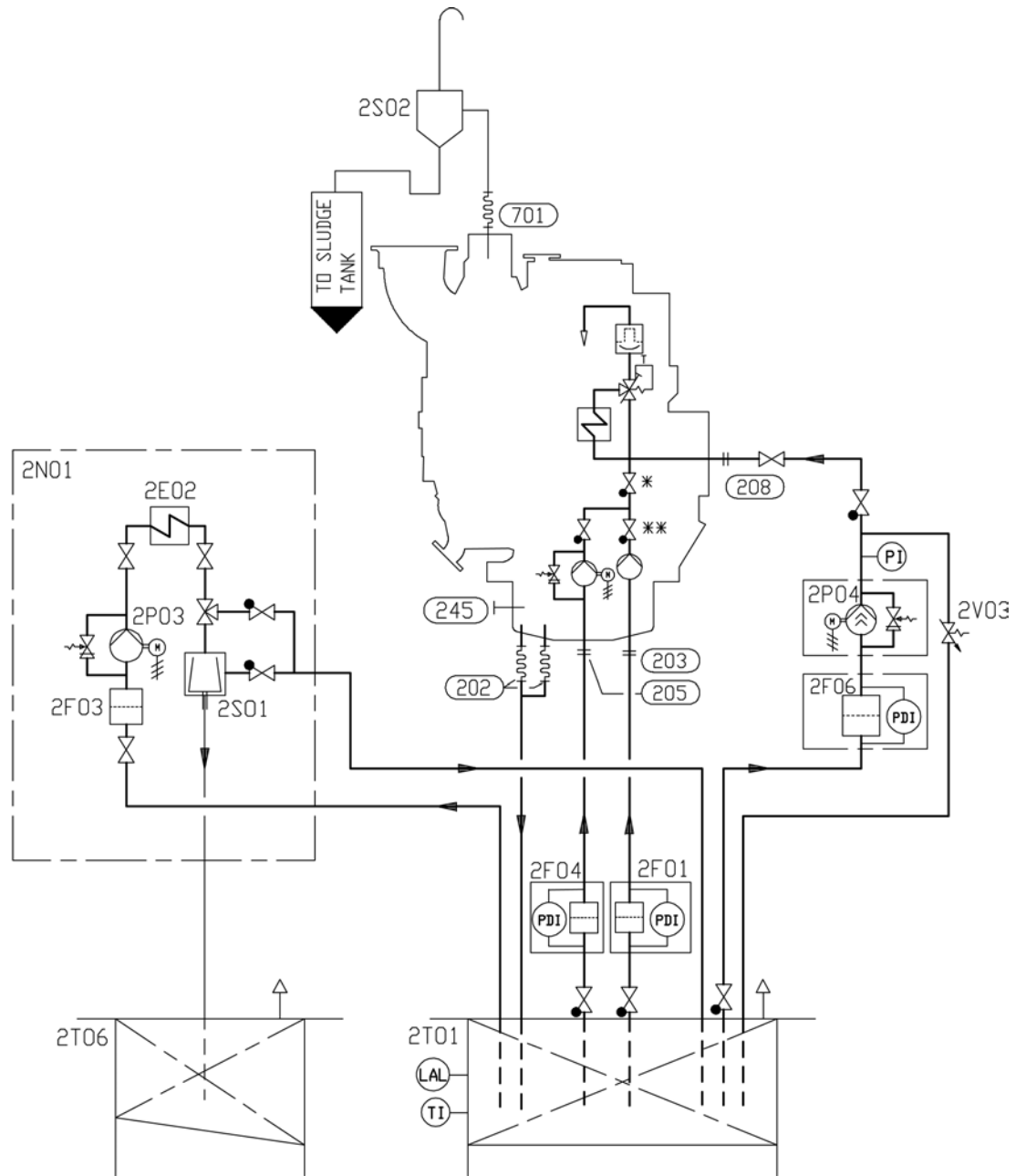

Fig 7-5 Lubricating oil system, auxiliary engines (V76E4590F)

System components		Pipe connections		Size
2E02	Heater (Separator unit)	213	Lubricating oil from separator and filling	DN32
2F03	Suction filter (Separator unit)	214	Lubricating oil to separator and drain	DN32
2N01	Separator unit	215	Lubricating oil filling	M48*2
2P03	Separator pump (Separator unit)	245	Priming pump lubrication drain	M12
2S01	Separator	701	Crankcase air vent	DN65
2S02	Condensate trap			
2T03	New oil tank			
2T04	Renovating oil tank			
2T05	Renovated oil tank			
2T06	Sludge tank			



* IF ENGINE WITH TC IN FLYWHEEL END

** IF STAND-BY PUMP & ENGINE WITH TC IN FREE END

Fig 7-6 Lubricating oil system, single main engine (V76E4591H)

System components		Pipe connections		Size
2E02	Heater (Separator unit)	202	Lubricating oil outlet (from oil sump)	DN100
2F01	Suction strainer (Main lubricating oil pump)	203	Lubricating oil to engine driven pump	DN100
2F03	Suction filter (Separator unit)	205	Lubricating oil to priming pump	DN32
2F04	Suction strainer (Prelubricating oil pump)	208	Lubricating oil from electric driven pump	DN80
2F06	Suction strainer (Stand-by pump)	245	Priming pump lubrication drain	M12
2N01	Separator unit	701	Crankcase air vent	DN65
2P03	Separator pump (Separator unit)			
2P04	Stand-by pump			

System components		Pipe connections		Size
2S01	Separator			
2S02	Condensate trap			
2T01	System oil tank			
2T06	Sludge tank			
2V03	Pressure control valve			

7.3.1 Separation system

7.3.1.1 Separator unit (2N01)

Each engine must have a dedicated lubricating oil separator and the separators shall be dimensioned for continuous separating. If the installation is designed to operate on MDF only, then intermittent separating might be sufficient.

Generating sets operating on a fuel having a viscosity of max. 380 cSt / 50°C may have a common lubricating oil separator unit. Three engines may have a common lubricating oil separator unit. In installations with four or more engines two lubricating oil separator units should be installed.

Separators are usually supplied as pre-assembled units.

Typically lubricating oil separator units are equipped with:

- Feed pump with suction strainer and safety valve
- Preheater
- Separator
- Control cabinet

The lubricating oil separator unit may also be equipped with an intermediate sludge tank and a sludge pump, which offers flexibility in placement of the separator since it is not necessary to have a sludge tank directly beneath the separator.

Separator feed pump (2P03)

The feed pump must be selected to match the recommended throughput of the separator. Normally the pump is supplied and matched to the separator by the separator manufacturer.

The lowest foreseen temperature in the system oil tank (after a long stop) must be taken into account when dimensioning the electric motor.

Separator preheater (2E02)

The preheater is to be dimensioned according to the feed pump capacity and the temperature in the system oil tank. When the engine is running, the temperature in the system oil tank located in the ship's bottom is normally 65...75°C. To enable separation with a stopped engine the heater capacity must be sufficient to maintain the required temperature without heat supply from the engine.

Recommended oil temperature after the heater is 95°C.

It shall be considered that, while the engine is stopped in stand-by mode without LT water circulation, the separator unit may be heating up the total amount of lubricating oil in the oil tank to a value higher than the nominal one required at engine inlet, after lube oil cooler (see Technical Data chapter). Higher oil temperatures at engine inlet than the nominal, may be creating higher component wear and in worst conditions damages to the equipment and generate alarm signal at engine start, or even a load reduction request to PMS.

The surface temperature of the heater must not exceed 150°C in order to avoid cooking of the oil.

The heaters should be provided with safety valves and drain pipes to a leakage tank (so that possible leakage can be detected).

Separator (2S01)

The separators should preferably be of a type with controlled discharge of the bowl to minimize the lubricating oil losses.

The service throughput Q [l/h] of the separator can be estimated with the formula:

$$Q = \frac{1.35 \times P \times n}{t}$$

where:

Q = volume flow [l/h]

P = engine output [kW]

n = 5 for HFO, 4 for MDF

t = operating time [h/day]: 24 for continuous separator operation, 23 for normal dimensioning

Sludge tank (2T06)

The sludge tank should be located directly beneath the separators, or as close as possible below the separators, unless it is integrated in the separator unit. The sludge pipe must be continuously falling.

7.3.1.2 Renovating oil tank (2T04)

In case of wet sump engines the oil sump content can be drained to this tank prior to separation.

7.3.1.3 Renovated oil tank (2T05)

This tank contains renovated oil ready to be used as a replacement of the oil drained for separation.

7.3.2 System oil tank (2T01)

Recommended oil tank volume is stated in chapter *Technical data*.

The system oil tank is usually located beneath the engine foundation. The tank may not protrude under the reduction gear or generator, and it must also be symmetrical in transverse direction under the engine. The location must further be such that the lubricating oil is not cooled down below normal operating temperature. Suction height is especially important with engine driven lubricating oil pump. Losses in strainers etc. add to the geometric suction height. Maximum suction ability of the pump is stated in chapter *Technical data*.

The pipe connection between the engine oil sump and the system oil tank must be flexible to prevent damages due to thermal expansion. The return pipes from the engine oil sump must end beneath the minimum oil level in the tank. Further on the return pipes must not be located in the same corner of the tank as the suction pipe of the pump.

The suction pipe of the pump should have a trumpet shaped or conical inlet to minimise the pressure loss. For the same reason the suction pipe shall be as short and straight as possible and have a sufficient diameter. A pressure gauge shall be installed close to the inlet of the lubricating oil pump. The suction pipe shall further be equipped with a non-return valve of flap type without spring. The non-return valve is particularly important with engine driven pump and it must be installed in such a position that self-closing is ensured.

Suction and return pipes of the separator must not be located close to each other in the tank.

The ventilation pipe from the system oil tank may not be combined with crankcase ventilation pipes.

It must be possible to raise the oil temperature in the tank after a long stop. In cold conditions it can be necessary to have heating coils in the oil tank in order to ensure pumpability. The separator heater can normally be used to raise the oil temperature once the oil is pumpable. Further heat can be transferred to the oil from the preheated engine, provided that the oil viscosity and thus the power consumption of the pre-lubricating oil pump does not exceed the capacity of the electric motor.

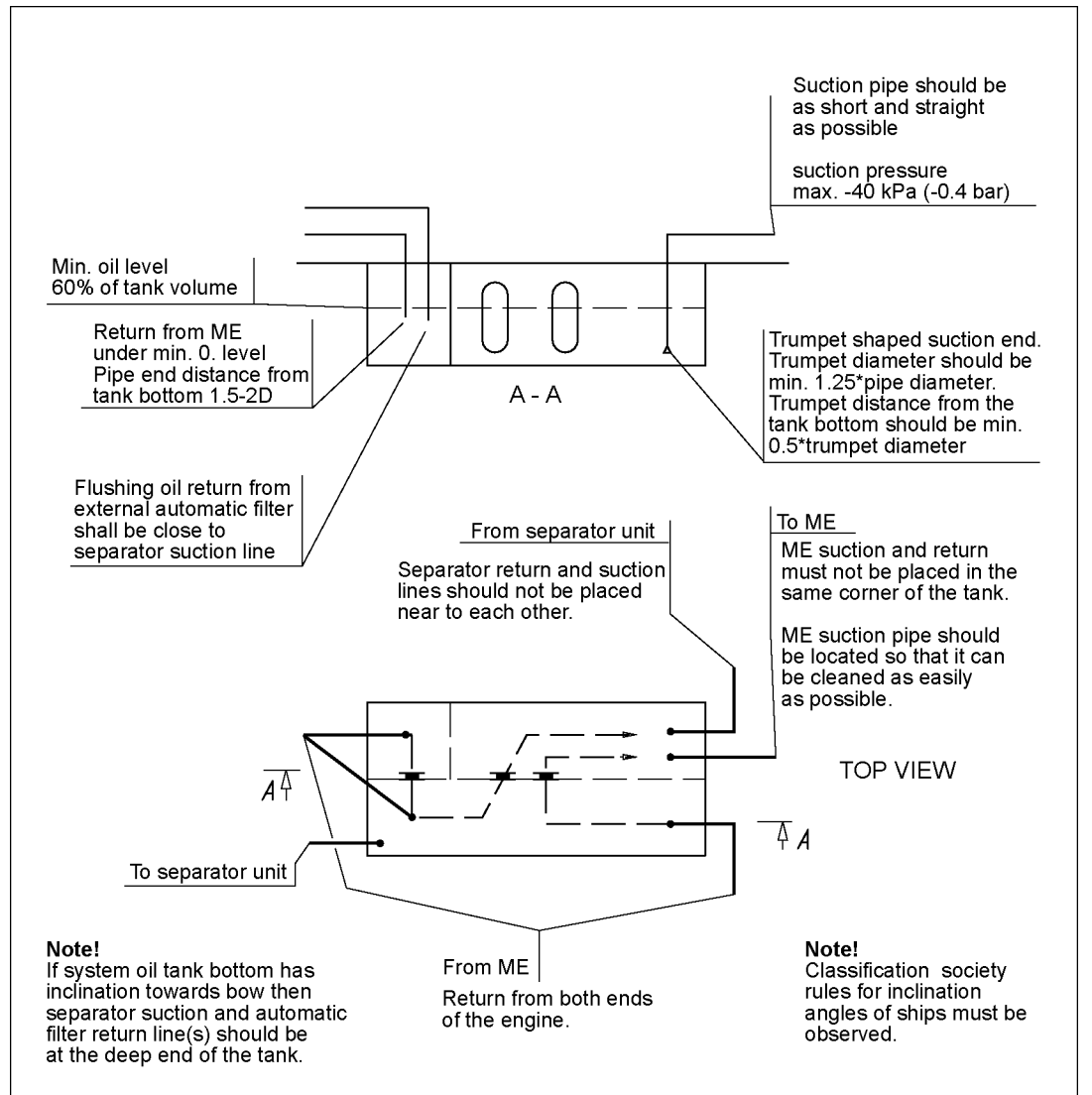

Fig 7-7 Example of system oil tank arrangement (DAAE007020e)

Design data:

Oil tank volume	1.2...1.5 l/kW, see also <i>Technical data</i>
Oil level at service	75...80% of tank volume
Oil level alarm	60% of tank volume

7.3.3 New oil tank (2T03)

In engines with wet sump, the lubricating oil may be filled into the engine, using a hose or an oil can, through the dedicated lubricating oil filling connection (215). Alternatively, through the crankcase cover or through the separator pipe. The system should be arranged so that it is possible to measure the filled oil volume.

7.3.4 Suction strainers (2F01, 2F04, 2F06)

It is recommended to install a suction strainer before each pump to protect the pump from damage. The suction strainer and the suction pipe must be amply dimensioned to minimize pressure losses. The suction strainer should always be provided with alarm for high differential pressure.

Design data:

Fineness	0.5...1.0 mm
----------	--------------

7.3.5 Lubricating oil pump, stand-by (2P04)

The stand-by lubricating oil pump is normally of screw type and should be provided with an safety valve.

Design data:

Capacity	see <i>Technical data</i>
Design pressure, max	0.8 MPa (8 bar)
Design temperature, max.	100°C
Lubricating oil viscosity	SAE 40
Viscosity for dimensioning the electric motor	500 mm ² /s (cSt)

7.4 Crankcase ventilation system

The purpose of the crankcase ventilation is to evacuate gases from the crankcase in order to keep the pressure in the crankcase within acceptable limits.

Each engine must have its own vent pipe into open air. The crankcase ventilation pipes may not be combined with other ventilation pipes, e.g. vent pipes from the system oil tank.

The diameter of the pipe shall be large enough to avoid excessive back pressure. Other possible equipment in the piping must also be designed and dimensioned to avoid excessive flow resistance.

A condensate trap must be fitted on the vent pipe near the engine.

The connection between engine and pipe is to be flexible. It is very important that the crankcase ventilation pipe is properly fixed to a support rigid in all directions directly after the flexible hose from crankcase ventilation outlet, extra mass on the oil mist detector must be avoided. There should be a fixing point on both sides of the pipe at the support. Absolutely rigid mounting between the pipe and the support is recommended. The supporting must allow thermal expansion and ship's structural deflections.

Design data:

Flow	see <i>Technical data</i>
Backpressure, max.	see <i>Technical data</i>
Temperature	80°C

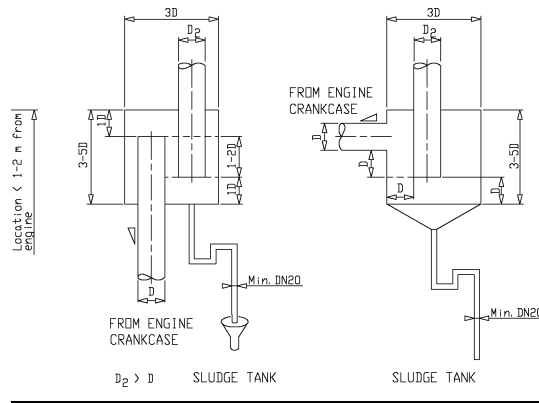

Fig 7-8 Condensate trap (DAAE032780B)

The size of the ventilation pipe (D₂) out from the condensate trap should be equal or bigger than the ventilation pipe (D) coming from the engine. For more information about ventilation pipe (D) size, see the external lubricating oil system drawing.

The max. back-pressure must also be considered when selecting the ventilation pipe size.

7.5 Flushing instructions

Flushing instructions in this Product Guide are for guidance only. For contracted projects, read the specific instructions included in the installation planning instructions (IPI). The fineness of the flushing filter and further instructions are found from installation planning instructions (IPI).

7.5.1 Piping and equipment built on the engine

Flushing of the piping and equipment built on the engine is not required and flushing oil shall not be pumped through the engine oil system (which is flushed and clean from the factory). It is however acceptable to circulate the flushing oil via the engine sump if this is advantageous. Cleanliness of the oil sump shall be verified after completed flushing.

7.5.2 External oil system

Refer to the system diagram(s) in section *External lubricating oil system* for location/description of the components mentioned below.

If the engine is equipped with a wet oil sump the external oil tanks, new oil tank (2T03), renovating oil tank (2T04) and renovated oil tank (2T05) shall be verified to be clean before bunkering oil. Especially pipes leading from the separator unit (2N01) directly to the engine shall be ensured to be clean for instance by disconnecting from engine and blowing with compressed air.

If the engine is equipped with a dry oil sump the external oil tanks, new oil tank and the system oil tank (2T01) shall be verified to be clean before bunkering oil.

Operate the separator unit continuously during the flushing (not less than 24 hours). Leave the separator running also after the flushing procedure, this to ensure that any remaining contaminants are removed.

If an electric motor driven stand-by pump (2P04) is installed then piping shall be flushed running the pump circulating engine oil through a temporary external oil filter (recommended mesh 34 microns) into the engine oil sump through a hose and a crankcase door. The pump shall be protected by a suction strainer (2F06).

Whenever possible the separator unit shall be in operation during the flushing to remove dirt. The separator unit is to be left running also after the flushing procedure, this to ensure that any remaining contaminants are removed.

7.5.3 Type of flushing oil

7.5.3.1 Viscosity

In order for the flushing oil to be able to remove dirt and transport it with the flow, ideal viscosity is 10...50 cSt. The correct viscosity can be achieved by heating engine oil to about 65°C or by using a separate flushing oil which has an ideal viscosity in ambient temperature.

7.5.3.2 Flushing with engine oil

The ideal is to use engine oil for flushing. This requires however that the separator unit is in operation to heat the oil. Engine oil used for flushing can be reused as engine oil provided that no debris or other contamination is present in the oil at the end of flushing.

7.5.3.3 Flushing with low viscosity flushing oil

If no separator heating is available during the flushing procedure it is possible to use a low viscosity flushing oil instead of engine oil. In such a case the low viscosity flushing oil must be disposed of after completed flushing. Great care must be taken to drain all flushing oil from

pockets and bottom of tanks so that flushing oil remaining in the system will not compromise the viscosity of the actual engine oil.

7.5.3.4 Lubricating oil sample

To verify the cleanliness a LO sample shall be taken by the shipyard after the flushing is completed. The properties to be analyzed are Viscosity, BN, AN, Insolubles, Fe and Particle Count.

Commissioning procedures shall in the meantime be continued without interruption unless the commissioning engineer believes the oil is contaminated.

This page intentionally left blank

8. Compressed Air System

Compressed air is used to start engines and to provide actuating energy for safety and control devices. The use of starting air for other purposes is limited by the classification regulations.

To ensure the functionality of the components in the compressed air system, the compressed air has to be free from solid particles and oil.

8.1 Internal compressed air system

The engine is equipped with a pneumatic starting motor driving the engine through a gear rim on the flywheel.

The compressed air system of the electro-pneumatic overspeed trip is connected to the starting air system. For this reason, the air supply to the engine must not be closed during operation.

The nominal starting air pressure of 3 MPa (30 bar) is reduced with a pressure regulator before the pneumatic starting motor.

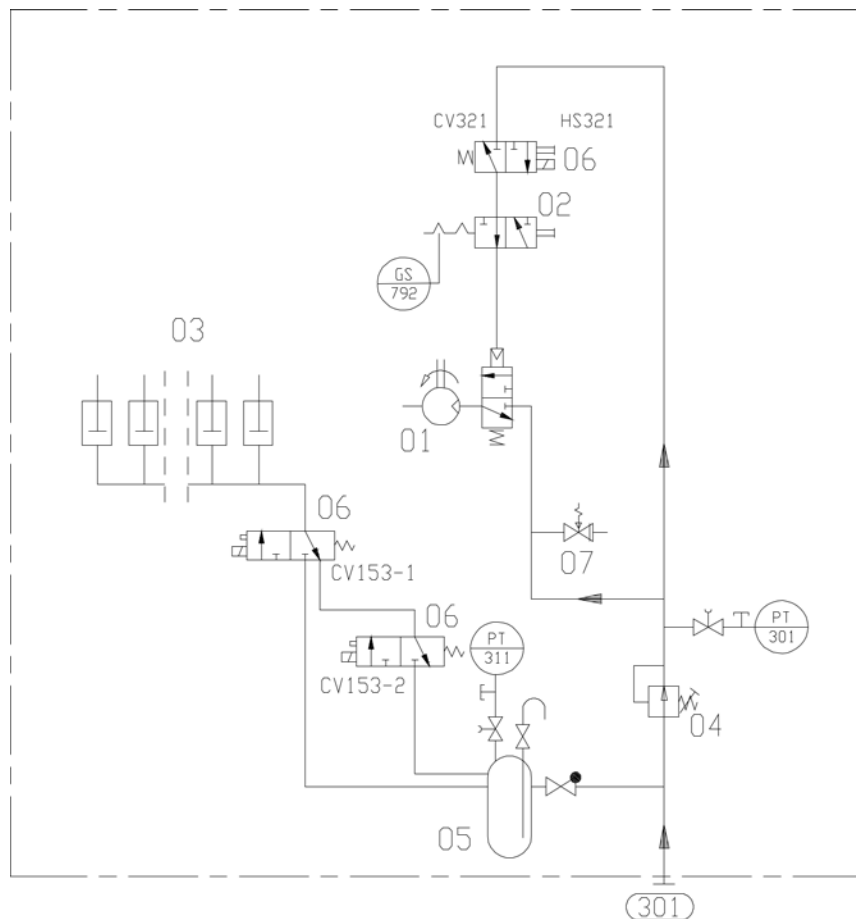
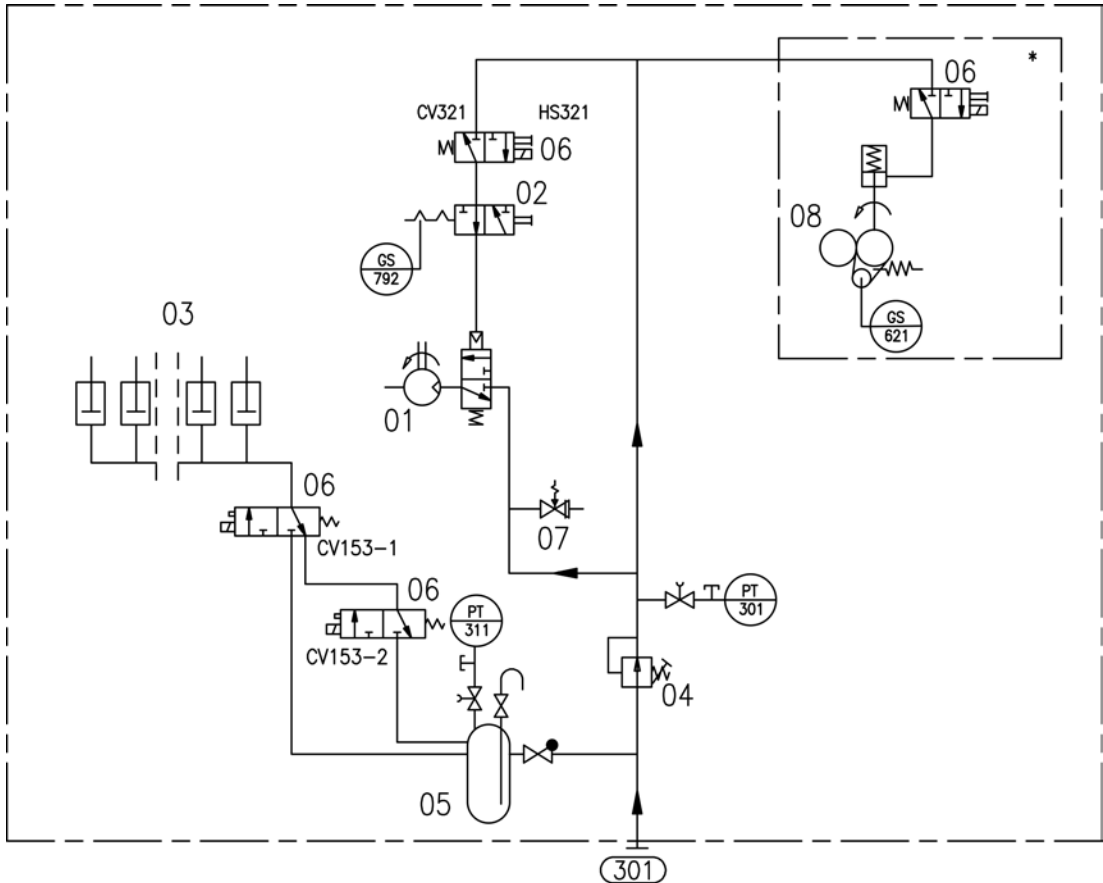

Fig 8-1 Internal starting air system, WA20 (DAAF382588C) - UNIC C1

System components:			
01	Turbine starter	05	Air container
02	Blocking valve, when turning gear engaged	06	Solenoid valve
03	Pneumatic cylinder at each injection pump (for overspeed)	07	Safety valve

Sensors and indicators:			
PT301	Starting air pressure, engine inlet	CV153-2	Stop/shutdown solenoid valve 2
PT311	Control air pressure	CV321	Start solenoid valve
GS792	Turning gear engaged	HS321	Emergency start

Pipe connections		Size
301	Starting air inlet	OD28



* ONLY FOR ENGINES WITH CHARGE AIR BLOCKING DEVICE FOR CHARGE AIR SYSTEM

T = TEST PLUG

Fig 8-2 Internal starting air system (DAAF395503C) - UNIC C2 & UNIC 2.0

System components:			
01	Turbine starter	05	Air container
02	Blocking valve, when turning gear engaged	06	Solenoid valve (optional)
03	Pneumatic cylinder for overspeed	07	Safety valve
04	Pressure regulator	08	Charge air blocking device (optional)

Sensors and indicators:			
PT301	Starting air pressure, engine inlet	CV153-1	Stop solenoid 1
PT311	Control air pressure, engine inlet	CV153-2	Stop solenoid 2

Sensors and indicators:			
GS792	Turning gear position	CV321	Starting solenoid
GS621	Charge air blocking device (optional)	HS321	EMERGENCY START

Pipe connections		Size
301	Starting air inlet, 3MPa	OD28

8.2 External compressed air system

The design of the starting air system is partly determined by classification regulations. Most classification societies require that the total capacity is divided into two equally sized starting air receivers and starting air compressors. The requirements concerning multiple engine installations can be subject to special consideration by the classification society.

The starting air pipes should always be slightly inclined and equipped with manual or automatic draining at the lowest points.

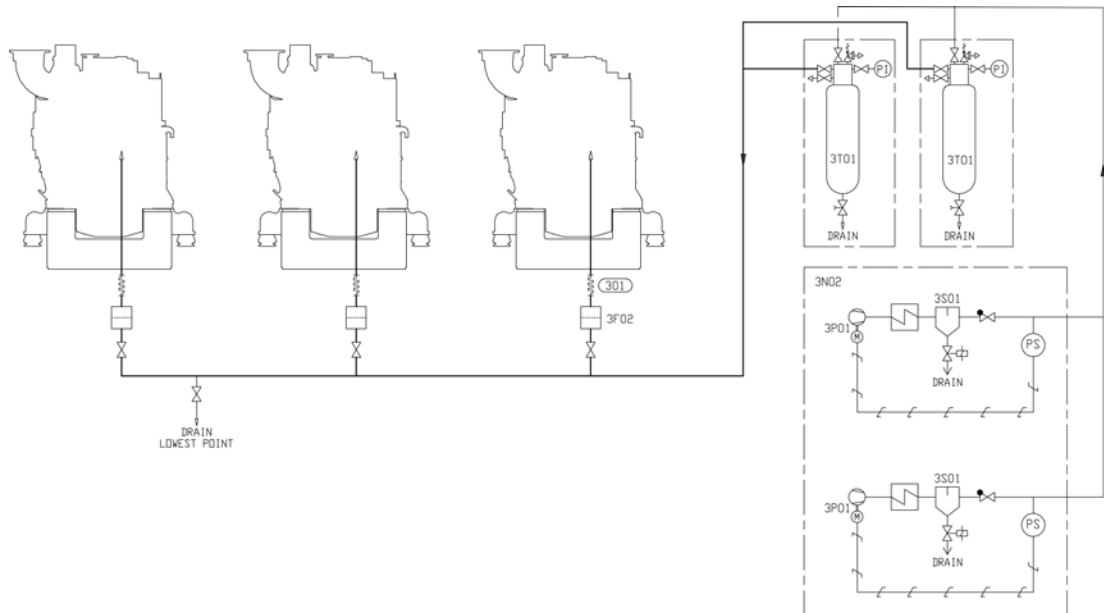

Fig 8-3 External starting air system (DAAE007204I)

System components			
3F02	Air filter (Starting air inlet)	3P01	Compressor (Starting air compressor unit)
3N02	Starting air compressor unit	3S01	Separator (Starting air compressor unit)

Pipe connections		Size
301	Starting air inlet	OD28

8.2.1 Starting air compressor unit (3N02)

At least two starting air compressors must be installed. It is recommended that the compressors are capable of filling the starting air vessel from minimum (1.8 MPa) to maximum pressure in 15...30 minutes. For exact determination of the minimum capacity, the rules of the classification societies must be followed.

8.2.2 Oil and water separator (3S01)

An oil and water separator should always be installed in the pipe between the compressor and the air vessel. Depending on the operation conditions of the installation, an oil and water separator may be needed in the pipe between the air vessel and the engine.

8.2.3 Starting air vessel (3T01)

The starting air vessels should be dimensioned for a nominal pressure of 3 MPa.

The number and the capacity of the air vessels for propulsion engines depend on the requirements of the classification societies and the type of installation.

It is recommended to use a minimum air pressure of 1.8 MPa, when calculating the required volume of the vessels.

The starting air vessels are to be equipped with at least a manual valve for condensate drain. If the air vessels are mounted horizontally, there must be an inclination of 3...5° towards the drain valve to ensure efficient draining.

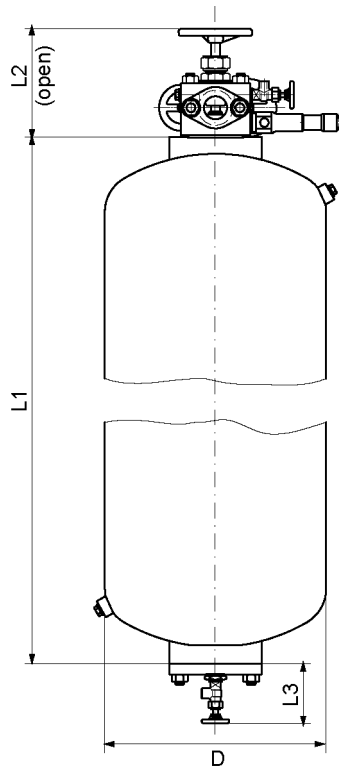

Size [Litres]	Dimensions [mm]				Weight [kg]
	L1	L2 1)	L3 1)	D	
125	1807	243	110	324	170
180	1217	243	110	480	200
250	1767	243	110	480	274
500	3204	243	133	480	450

1) Dimensions are approximate.

Fig 8-4 Starting air vessel

The starting air consumption stated in technical data is for a successful start. During start the main starting valve is kept open until the engine starts, or until the max. time for the starting attempt has elapsed. A failed start can consume two times the air volume stated in technical data. If the ship has a class notation for unattended machinery spaces, then the starts are to be demonstrated.

The required total starting air vessel volume can be calculated using the formula:

$$V_R = \frac{p_E \times V_E \times n}{p_{Rmax} - p_{Rmin}}$$

where:

V_R = total starting air vessel volume [m³]

p_E = normal barometric pressure (NTP condition) = 0.1 MPa

V_E = air consumption per start [Nm³] See *Technical data*

n = required number of starts according to the classification society

p_{Rmax} = maximum starting air pressure = 3 MPa

p_{Rmin} = minimum starting air pressure = See *Technical data*

NOTE

The total vessel volume shall be divided into at least two equally sized starting air vessels.

8.2.4 Air filter, starting air inlet (3F02)

Condense formation after the water separator (between starting air compressor and starting air vessels) create and loosen abrasive rust from the piping, fittings and receivers. Therefore it is recommended to install a filter before the starting air inlet on the engine to prevent particles to enter the starting air equipment.

An Y-type strainer can be used with a stainless steel screen and mesh size 75 μm . The pressure drop should not exceed 20 kPa (0.2 bar) for the engine specific starting air consumption under a time span of 4 seconds.

The starting air filter is mandatory for Wärtsilä 20 engines.

9. Cooling Water System

9.1 Water quality

The fresh water in the cooling water system of the engine must fulfil the following requirements:

pH min. 6.5...8.5

Hardness max. 10 °dH

Chlorides max. 80 mg/l

Sulphates max. 150 mg/l

Good quality tap water can be used, but shore water is not always suitable. It is recommended to use water produced by an onboard evaporator. Fresh water produced by reverse osmosis plants often has higher chloride content than permitted. Rain water is unsuitable as cooling water due to the high content of oxygen and carbon dioxide.

Only treated fresh water containing approved corrosion inhibitors may be circulated through the engines. It is important that water of acceptable quality and approved corrosion inhibitors are used directly when the system is filled after completed installation.

9.1.1 Corrosion inhibitors

The use of an approved cooling water additive is mandatory. An updated list of approved products is supplied for every installation and it can also be found in the Instruction manual of the engine, together with dosage and further instructions.

9.1.2 Glycol

Use of glycol in the cooling water is not recommended unless it is absolutely necessary. Starting from 20% glycol the engine is to be de-rated 0.23 % per 1% glycol in the water. Max. 60% glycol is permitted.

Corrosion inhibitors shall be used regardless of glycol in the cooling water.

9.2 Internal cooling water system

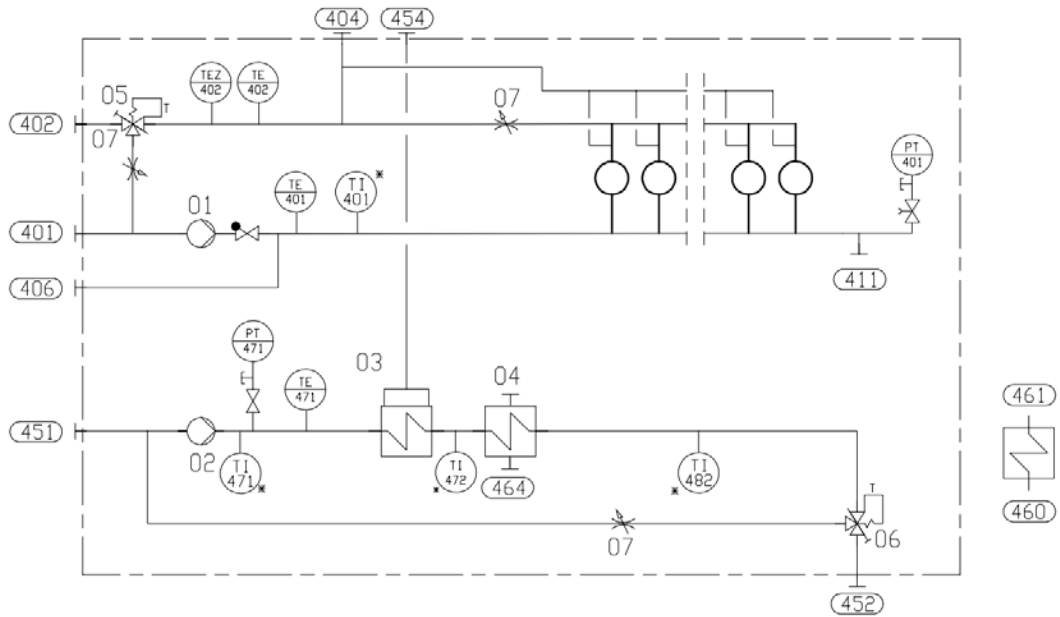

NOTE



*Optional
T = Test plug

Fig 9-1 Internal cooling water system (DAAF382591C) - UNIC C1

System components:

01	HT-cooling water pump	05	HT-thermostatic valve
02	LT-cooling water pump	06	LT-thermostatic valve
03	Charge air cooler	07	Adjustable orifice

Sensors and Indicators:

PT401	HT water pressure, jacket inlet	TI482	LT water temperature, LOC outlet
TI472	LT water temperature, CAC outlet	PT471	LT water pressure, CAC inlet
TE402	HT water temperature, jacket outlet	TE471	LT water temperature, CAC inlet
TE401	HT water temperature, jacket inlet	TI471	LT water temperature, CAC inlet
TI401	HT water temperature, engine inlet	TEZ402	HT water temperature, jacket outlet

Pipe connections

	Size	Pressure class	Standard	
401	HT-water inlet	DN65	PN16	ISO 7005-1
402	HT-water outlet	DN65	PN16	ISO 7005-1
404	HT-water air vent	OD12	PN250	DIN 2353
406	Water from preheater to HT-circuit	DN65 or OD28	PN16 or PN250	ISO 7005-1 or DIN 2353
411	HT-water drain	M10 x 1	-	Plug
451	LT-water inlet	DN80	PN16	ISO 7005-1
452	LT-water outlet	DN80	PN16	ISO 7005-1
454	LT-water air vent from air cooler	OD12	PN250	DIN 2353
460	LT-water from generator	TBA	TBA	TBA

Pipe connections	Size	Pressure class	Standard
461	LT-water to generator	TBA	TBA
464	LT-water drain	M18 x 1.5	Plug

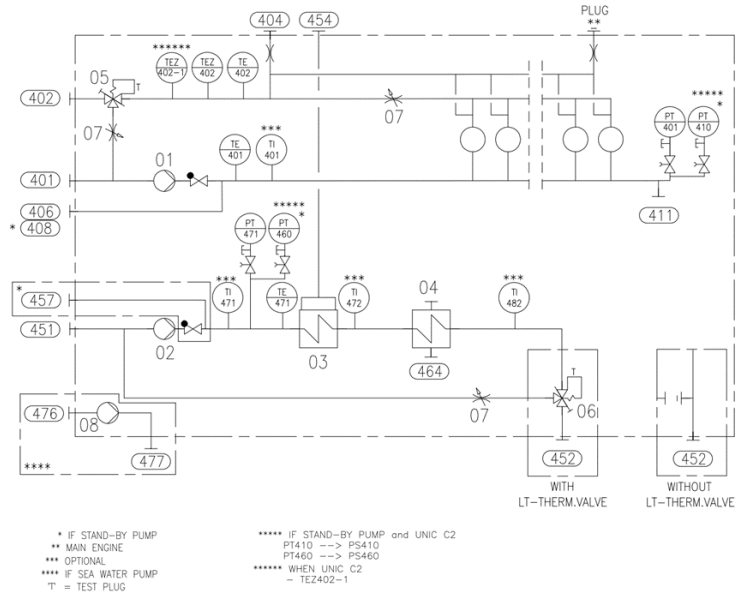

Fig 9-2 Internal cooling water system (DAAF395504E) - UNIC C2 & UNIC 2.0

System components:			
01	HT-cooling water pump	05	HT-thermostatic valve
02	LT-cooling water pump	****06	LT-thermostatic valve
03	Charge air cooler	07	Adjustable orifice
04	Lubricating oil cooler	08	Sea water pump (option)

Sensors and Indicators:			
PT401	HT water pressure, jacket inlet	***TI482	LT water temperature, LOC outlet
*PT410	HT water pressure, stand-by pump	PT471	LT water pressure, CAC inlet
*PT460	LT water pressure, stand-by pump	TE471	LT water temperature, CAC inlet
TE401	HT water temperature, jacket inlet	***TI471	LT water temperature, CAC inlet
***TI401	HT water temperature, jacket inlet	TEZ402	HT water temperature, jacket outlet
TE402	HT water temperature, jacket outlet	***TI472	LT water temperature, CAC outlet
****PS410	HT water stand-by pump start	****PS460	LT water stand-by pump start
*****TEZ402-1	HT water temperature, jacket outlet		

Pipe connections	Size	Pressure class	Standard
401	HT-water inlet	DN65	PN16
402	HT-water outlet	DN65	PN16
404	HT-water air vent	OD12	PN250
406	Water from preheater to HT-circuit	DN65 or OD28	PN16 or PN250
*408	HT-water from stand-by pump	DN65	PN16
411	HT-water drain	M10 x 1	-
451	LT-water inlet	DN80	PN16

Pipe connections		Size	Pressure class	Standard
452	LT-water outlet	DN80	PN16	ISO 7005-1
454	LT-water air vent from air cooler	OD12	PN250	DIN 2353
*457	LT-water from stand-by pump	DN80	PN16	ISO 7005-1
464	LT-water drain	M18 x 1.5	-	Plug
****476	Sea water to engine driven pump (option)	TBA	TBA	TBA
****477	Sea water from engine driven pump (option)	TBA	TBA	TBA

The fresh water cooling system is divided into a high temperature (HT) and a low temperature (LT) circuit. The HT water circulates through cylinder jackets and cylinder heads.

The LT water circulates through the charge air cooler and the lubricating oil cooler, which is built on the engine.

Temperature control valves regulate the temperature of the water out from the engine, by circulating some water back to the cooling water pump inlet. The HT temperature control valve is always mounted on the engine, while the LT temperature control valve can be either on the engine or separate. In installations where the engines operate on MDF only it is possible to install the LT temperature control valve in the external system and thus control the LT water temperature before the engine.

9.2.1 Engine driven circulating pumps

The LT and HT cooling water pumps are engine driven. The engine driven pumps are located at the free end of the engine.

Pump curves for engine driven pumps are shown in the diagrams. The nominal pressure and capacity can be found in the chapter *Technical data*.

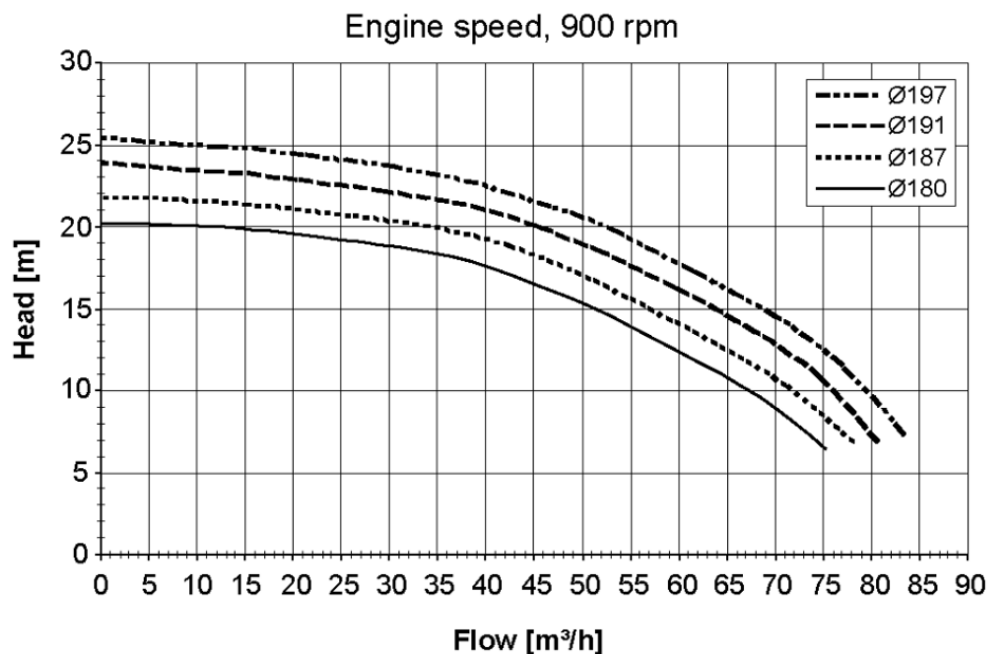

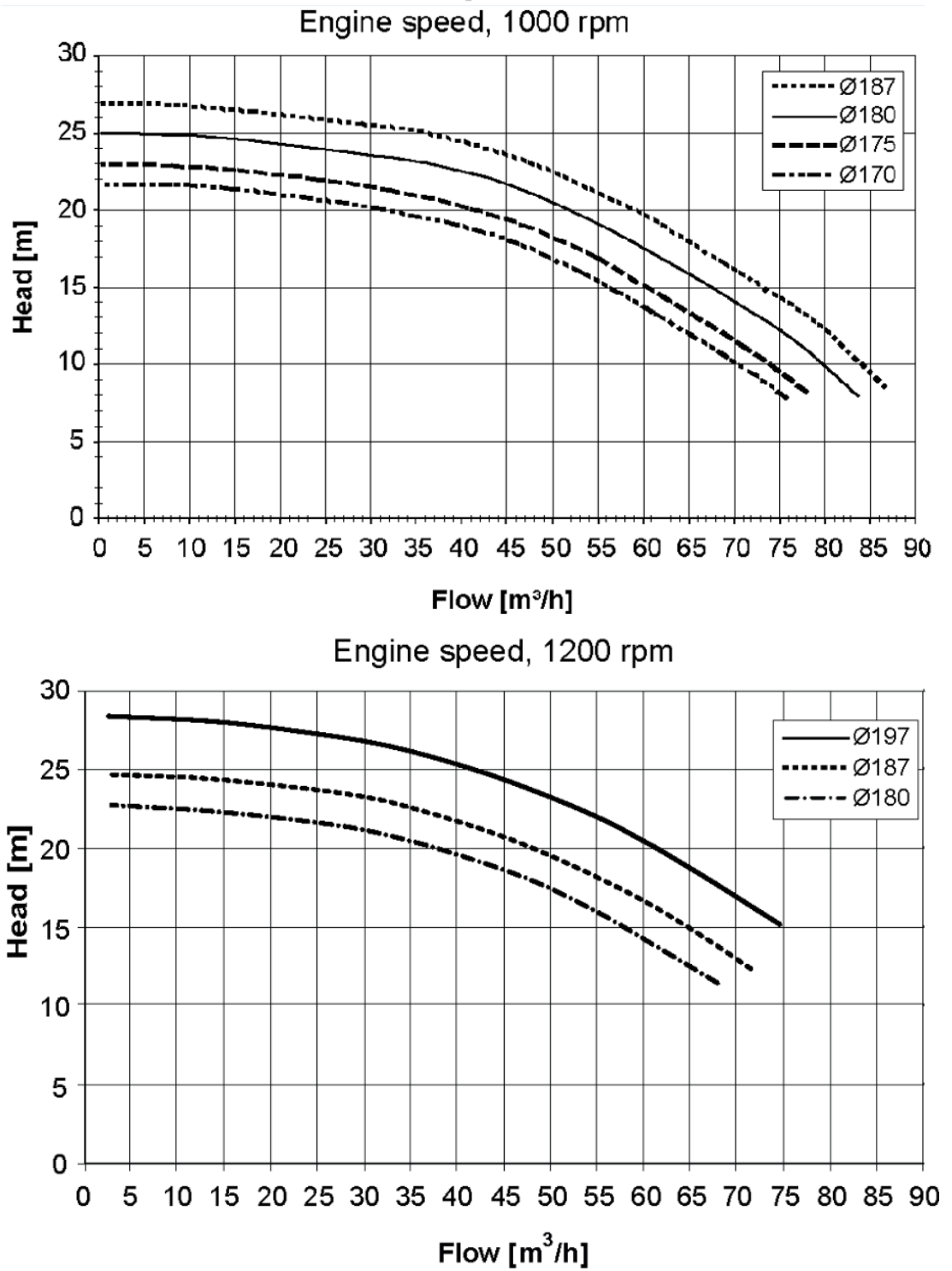

Fig 9-3 Pump curves

Table 9-1 Impeller diameters of engine driven HT & LT pumps

Engine type	Engine speed [rpm]	HT impeller [Ø mm]	LT impeller [Ø mm]
W 4L20	900	180	187
	1000	170	170

Engine type	Engine speed [rpm]	HT impeller [Ø mm]	LT impeller [Ø mm]
W 6L20	900	187	187
	1000	175	175
	1200	180	187
W 8L20	900	191	197
	1000	180	187
	1200	187	197
W 9L20	900	191	197
	1000	180	187
	1200	187	197

9.2.2 Engine driven sea water pump

An engine driven sea water pump is available for main engines:

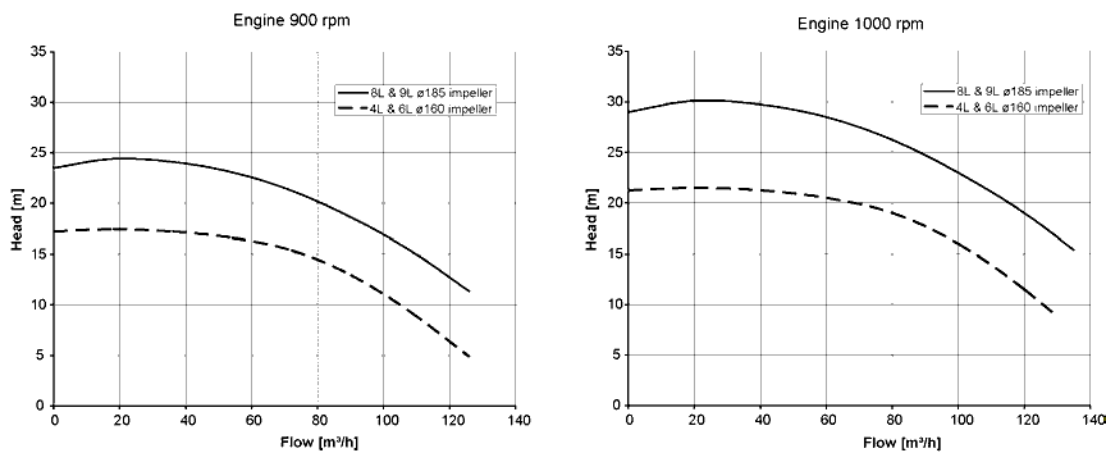

Fig 9-4 Engine driven sea water pump curves

9.3 External cooling water system

It is recommended to divide the engines into several circuits in multi-engine installations. One reason is of course redundancy, but it is also easier to tune the individual flows in a smaller system. Malfunction due to entrained gases, or loss of cooling water in case of large leaks can also be limited. In some installations it can be desirable to separate the HT circuit from the LT circuit with a heat exchanger.

The external system shall be designed so that flows, pressures and temperatures are close to the nominal values in *Technical data* and the cooling water is properly de-aerated.

Pipes with galvanized inner surfaces are not allowed in the fresh water cooling system. Some cooling water additives react with zinc, forming harmful sludge. Zinc also becomes nobler than iron at elevated temperatures, which causes severe corrosion of engine components.

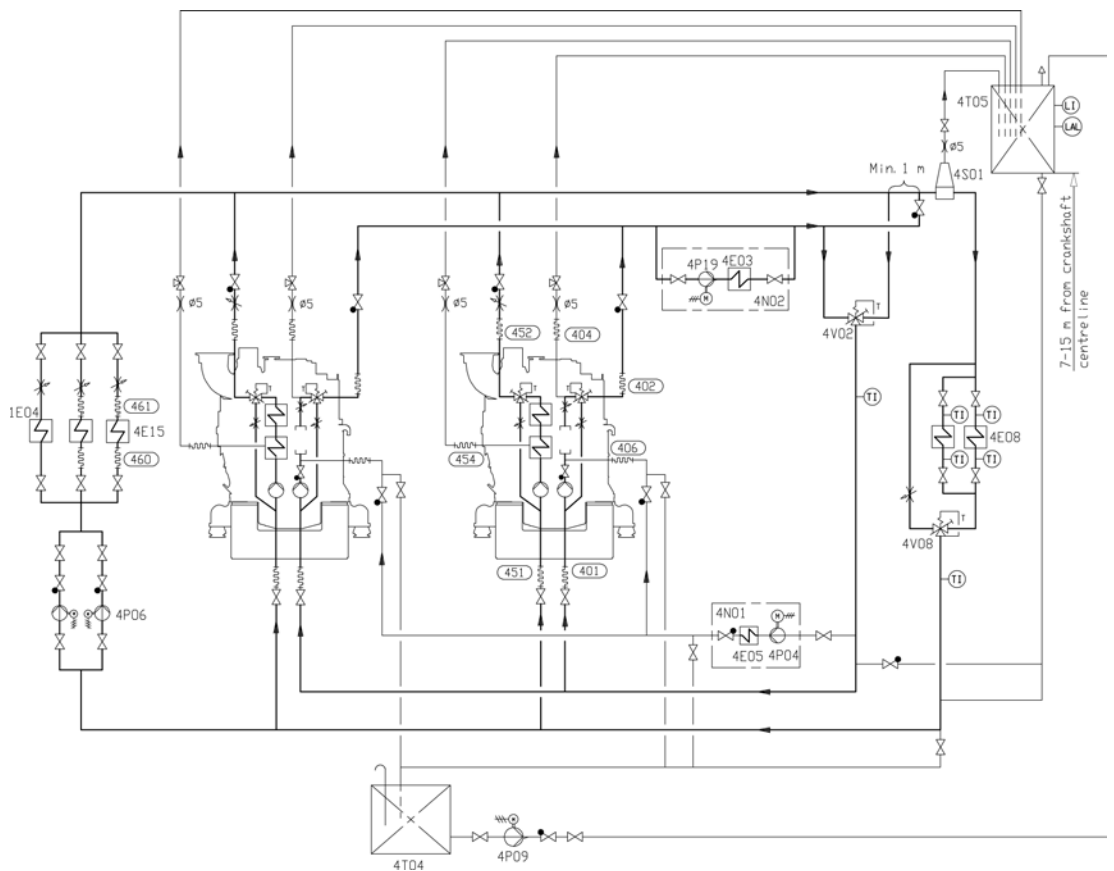

Fig 9-5 Cooling water system, HFO engines with heat recovery (DAAF068123B)

System components:			
1E04	Cooler (MDF)	4P06	Circulating pump
4E03	Heat recovery (Evaporator)	4P09	Transfer pump
4E05	Heater (Preheater)	4P19	Circulating pump (Evaporator)
4E08	Central cooler	4S01	Air venting
4E15	Cooler (Generator)	4T04	Drain tank
4N01	Preheating unit	4T05	Expansion tank
4N02	Evaporator unit	4V02	Temperature control valve (Heat recovery)
4P04	Circulating pump (Preheater)	4V08	Temperature control valve (Central cooler)

Pos	Pipe connections	Size
401	HT-water inlet	DN65

Pos	Pipe connections	Size
402	HT-water outlet	DN65
404	HT-air vent	OD12
406	Water from preheater to HT-circuit	OD28
451	LT-water inlet	DN80
452	LT-water outlet	DN80
454	LT-water air vent from air cooler	OD12
460	LT-water to generator	-
461	LT-water from generator	-

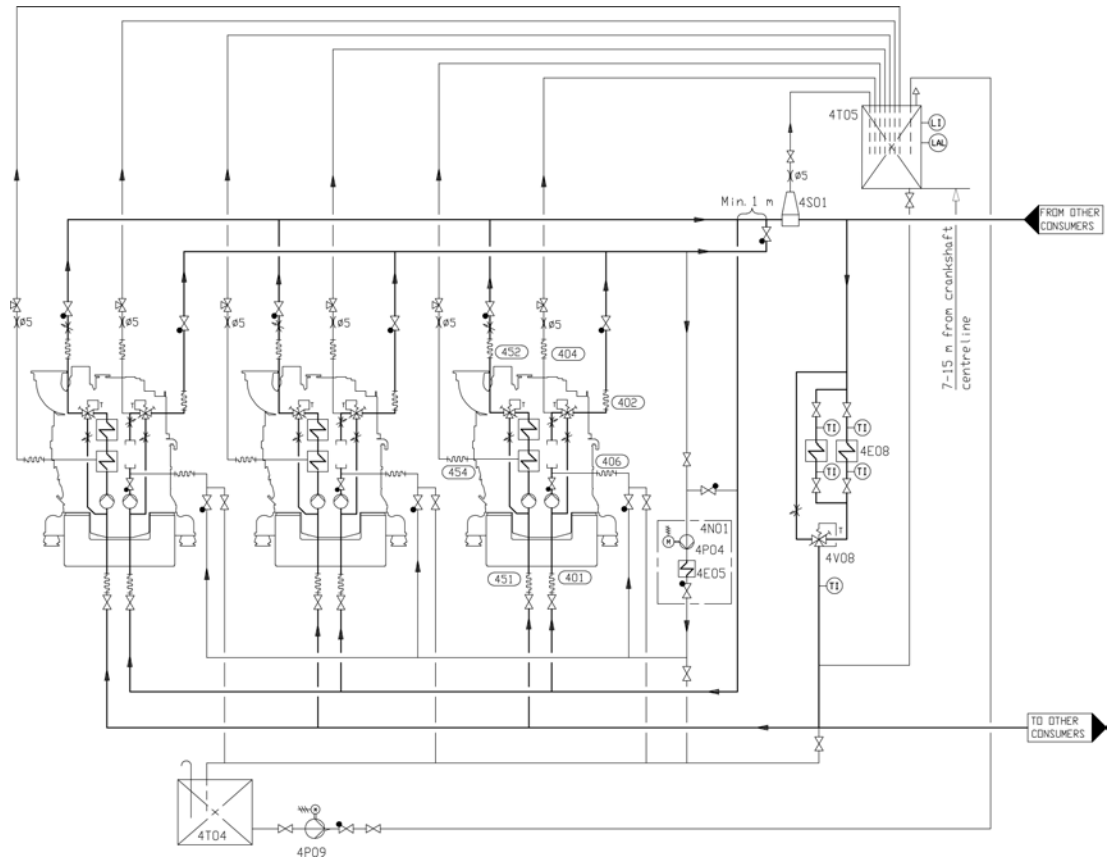

Fig 9-6 Cooling water system, auxiliary engines operating on HFO and MDO without heat recovery (V76C5823D)

System components:			
4E05	Heater (Preheater)	4S01	Air venting
4E08	Central cooler	4T04	Drain tank
4N01	Preheating unit	4T05	Expansion tank
4P04	Circulating pump (Preheater)	4V08	Temperature control valve (central cooler)
4P09	Transfer pump		
<i>Pipe connections are listed in section "Internal cooling water system".</i>			

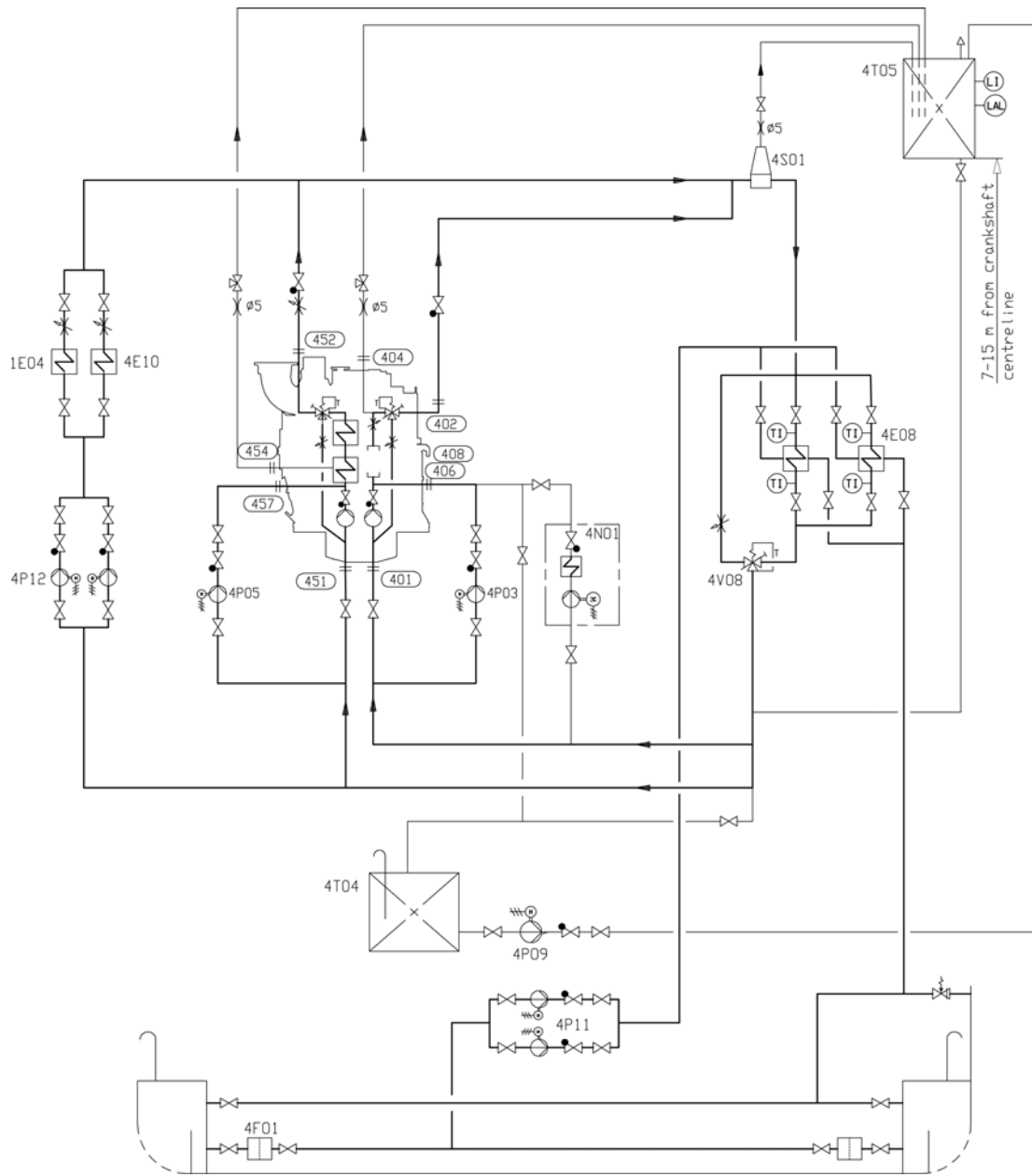

Fig 9-7 Cooling water system, single main engine (V76C5825D)

System components:			
1E04	Cooler (MDF)	4P09	Transfer pump
4E08	Central cooler	4P11	Circulating pump (Sea water)
4E10	Cooler (Reduction gear)	4P12	Circulating pump
4F01	Suction strainer (Sea water)	4S01	Air venting
4N01	Preheating unit	4T04	Drain tank
4P03	Stand-by pump (HT)	4T05	Expansion tank
4P05	Stand-by pump (LT)	4V08	Temperature control valve (Central cooler)

Pipe connections are listed in section "Internal cooling water system".

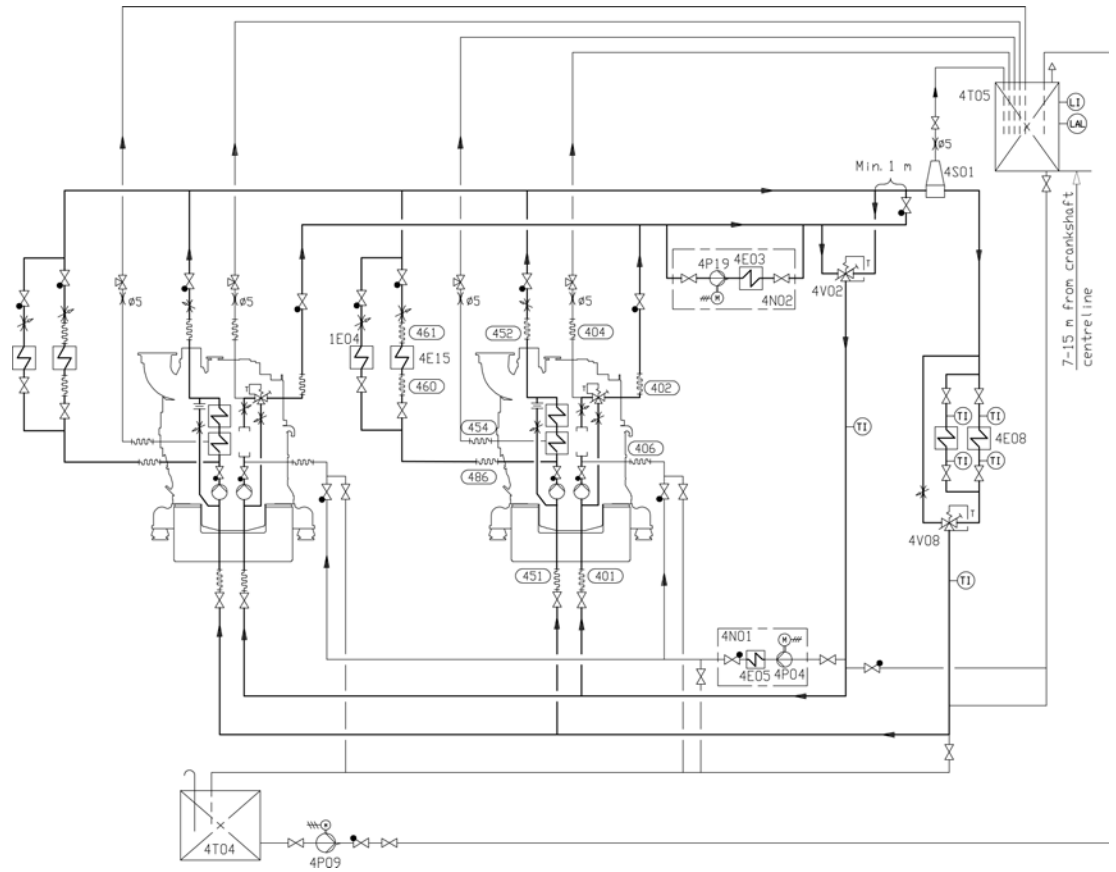

Fig 9-8 Cooling water system, MDF engines with heat recovery (V76C5827D)

System components:			
1E04	Cooler (MDF)	4P09	Transfer pump
4E03	Heat recovery (Evaporator)	4P19	Circulating pump (Evaporator)
4E05	Heater (Preheater)	4S01	Air venting
4E08	Central cooler	4T04	Drain tank
4E15	Cooler (Generator)	4T05	Expansion tank
4N01	Preheating unit	4V02	Thermostatic control valve (Heat recovery)
4N02	Evaporator unit	4V08	Thermostatic control valve (Central cooler)
4P04	Circulating pump (Preheater)		
Pipe connections are listed in section "Internal cooling water system".			

Ships (with ice class) designed for cold sea-water should have provisions for recirculation back to the sea chest from the central cooler:

- For melting of ice and slush, to avoid clogging of the sea water strainer
- To enhance the temperature control of the LT water, by increasing the seawater temperature

9.3.1 Stand-by circulation pumps (4P03, 4P05)

Stand-by pumps should be of centrifugal type and electrically driven. Required capacities and delivery pressures are stated in *Technical data*.

NOTE



Some classification societies require that spare pumps are carried onboard even though the ship has multiple engines. Stand-by pumps can in such case be worth considering also for this type of application.

9.3.2 Sea water pump (4P11)

The capacity of electrically driven sea water pumps is determined by the type of coolers and the amount of heat to be dissipated.

Significant energy savings can be achieved in most installations with frequency control of electrically driven sea water pumps. Minimum flow velocity (fouling) and maximum sea water temperature (salt deposits) are however issues to consider.

9.3.3 Temperature control valve for central cooler (4V08)

When it is desired to utilize the engine driven LT-pump for cooling of external equipment, e.g. a reduction or a generator, there must be a common LT temperature control valve in the external system, instead of an individual valve for each engine. The common LT temperature control valve is installed after the central cooler and controls the temperature of the water before the engine and the external equipment, by partly bypassing the central cooler. The valve can be either direct acting or electrically actuated.

The set-point of the temperature control valve 4V08 is 38 °C in the type of system described above.

Engines operating on HFO must have individual LT temperature control valves. A separate pump is required for the external equipment in such case, and the set-point of 4V08 can be lower than 38 °C if necessary.

9.3.4 Fresh water central cooler (4E08)

The fresh water cooler can be of either plate, tube or box cooler type. Plate coolers are most common. Several engines can share the same cooler.

It can be necessary to compensate a high flow resistance in the circuit with a smaller pressure drop over the central cooler.

The flow to the fresh water cooler must be calculated case by case based on how the circuit is designed.

In case the fresh water central cooler is used for combined LT and HT water flows in a parallel system the total flow can be calculated with the following formula:

$$q = q_{LT} + \frac{3.6 \times \Phi}{4.15 \times (T_{OUT} - T_{IN})}$$

where:

q = total fresh water flow [m³/h]

- q_{LT} = nominal LT pump capacity[m³/h]
- Φ = heat dissipated to HT water [kW]
- T_{out} = HT water temperature after engine (91°C)
- T_{in} = HT water temperature after cooler (38°C)

Design data:

- Fresh water flow see chapter *Technical Data*
- Heat to be dissipated see chapter *Technical Data*
- Pressure drop on fresh water side max. 60 kPa (0.6 bar)
- Sea-water flow acc. to cooler manufacturer, normally 1.2 - 1.5 x the fresh water flow
- Pressure drop on sea-water side, norm. acc. to pump head, normally 80 - 140 kPa (0.8 - 1.4 bar)
- Fresh water temperature after LT cooler max. 38 °C
- Fresh water temperature after HT cooler max. 83 °C
- Margin (heat rate, fouling) 15%

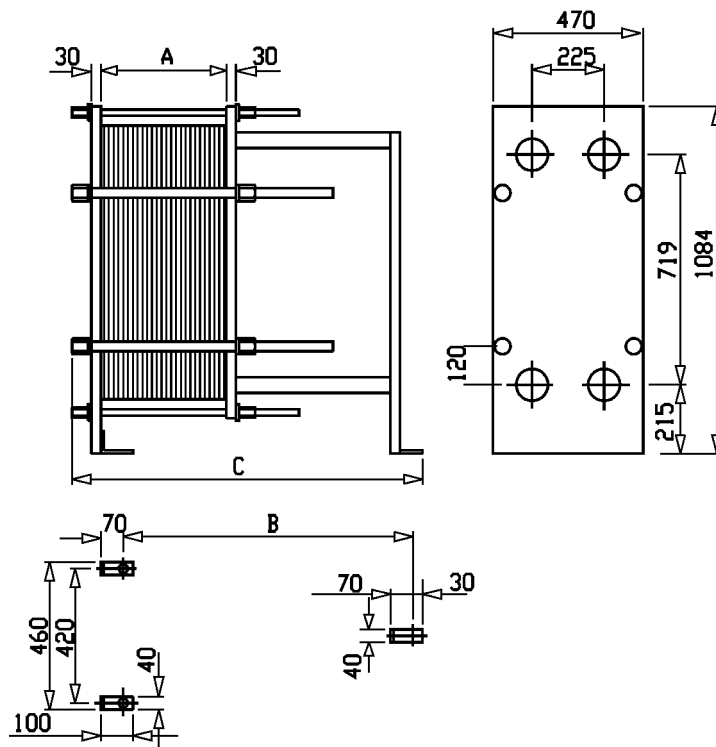

Fig 9-9 Central cooler, main dimensions (4V47E0188b)

Engine type	[rpm]	Cooling water			Sea water			Dimension [mm]			Weight [kg]	
		Flow [m ³ /h]	T _{cw, in} [°C]	T _{cw, out} [°C]	Flow [m ³ /h]	T _{sw, in} [°C]	T _{sw, out} [°C]	A	B	C	Dry	Wet
W4L20	1000	27	54.3	38	36	32	44.3	106	505	695	275	298
W6L20	1000	40	53.3	38	53	32	43.5	150	655	845	288	321
W8L20	1000	53	53.6	38	71	32	43.8	198	655	845	298	341
W9L20	1000	59	53.7	38	80	32	43.8	221	905	1095	305	354

As an alternative for the central coolers of the plate or of the tube type a box cooler can be installed. The principle of box cooling is very simple. Cooling water is forced through a U-tube-bundle, which is placed in a sea-chest having inlet- and outlet-grids. Cooling effect is reached by natural circulation of the surrounding water. The outboard water is warmed up and rises by its lower density, thus causing a natural upward circulation flow which removes the heat.

Box cooling has the advantage that no raw water system is needed, and box coolers are less sensitive for fouling and therefore well suited for shallow or muddy waters.

9.3.5 Waste heat recovery

The waste heat in the HT cooling water can be used for fresh water production, central heating, tank heating etc. The system should in such case be provided with a temperature control valve to avoid unnecessary cooling, as shown in the example diagrams. With this arrangement the HT water flow through the heat recovery can be increased.

The heat available from HT cooling water is affected by ambient conditions. It should also be taken into account that the recoverable heat is reduced by circulation to the expansion tank, radiation from piping and leakages in temperature control valves.

9.3.6 Air venting

Air may be entrained in the system after an overhaul, or a leak may continuously add air or gas into the system. The engine is equipped with vent pipes to evacuate air from the cooling water circuits. The vent pipes should be drawn separately to the expansion tank from each connection on the engine.

Venting pipes to the expansion tank are to be installed at all high points in the piping system, where air or gas can accumulate.

The vent pipes must be continuously rising.

9.3.7 Expansion tank (4T05)

The expansion tank compensates for thermal expansion of the coolant, serves for venting of the circuits and provides a sufficient static pressure for the circulating pumps.

Design data:

Pressure from the expansion tank at pump inlet	70 - 150 kPa (0.7...1.5 bar)
Volume	min. 10% of the total system volume

NOTE



The maximum pressure at the engine must not be exceeded in case an electrically driven pump is installed significantly higher than the engine.

Concerning the water volume in the engine, see chapter *Technical data*.

The expansion tank should be equipped with an inspection hatch, a level gauge, a low level alarm and necessary means for dosing of cooling water additives.

The vent pipes should enter the tank below the water level. The vent pipes must be drawn separately to the tank (see air venting) and the pipes should be provided with labels at the expansion tank.

The balance pipe down from the expansion tank must be dimensioned for a flow velocity not exceeding 1.0...1.5 m/s in order to ensure the required pressure at the pump inlet with engines

running. The flow through the pipe depends on the number of vent pipes to the tank and the size of the orifices in the vent pipes. The table below can be used for guidance.

Table 9-2 Minimum diameter of balance pipe

Nominal pipe size	Max. flow velocity (m/s)	Max. number of vent pipes with \varnothing 5 mm orifice
DN 32	1.1	3
DN 40	1.2	6
DN 50	1.3	10
DN 65	1.4	17

9.3.8 Drain tank (4T04)

It is recommended to collect the cooling water with additives in a drain tank, when the system has to be drained for maintenance work. A pump should be provided so that the cooling water can be pumped back into the system and reused.

Concerning the water volume in the engine, see chapter *Technical data*. The water volume in the LT circuit of the engine is small.

9.3.9 HT preheating

The cooling water circulating through the cylinders must be preheated to at least 60 °C, preferably 70 °C. This is an absolute requirement for installations that are designed to operate on heavy fuel, but strongly recommended also for engines that operate exclusively on marine diesel fuel.

The energy required for preheating of the HT cooling water can be supplied by a separate source or by a running engine, often a combination of both. In all cases a separate circulating pump must be used. It is common to use the heat from running auxiliary engines for preheating of main engines. In installations with several main engines the capacity of the separate heat source can be dimensioned for preheating of two engines, provided that this is acceptable for the operation of the ship. If the cooling water circuits are separated from each other, the energy is transferred over a heat exchanger.

9.3.9.1 HT heater (4E05)

The energy source of the heater can be electric power, steam or thermal oil.

It is recommended to heat the HT water to a temperature near the normal operating temperature. The heating power determines the required time to heat up the engine from cold condition.

The minimum required heating power is 2 kW/cyl, which makes it possible to warm up the engine from 20 °C to 60...70 °C in 10-15 hours. The required heating power for shorter heating time can be estimated with the formula below. About 1 kW/cyl is required to keep a hot engine warm.

Design data:

Preheating temperature	min. 60°C for starts at LFO or gas; Min 70°C for startings at HFO
Required heating power	2 kW/cyl
Heating power to keep hot engine warm	1 kW/cyl

Required heating power to heat up the engine, see formula below:

$$P = \frac{(T_1 - T_0)(m_{\text{eng}} \times 0.14 + V_{\text{LO}} \times 0.48 + V_{\text{FW}} \times 1.16)}{t} + k_{\text{eng}} \times n_{\text{cyl}}$$

where:

P	= Preheater output [kW]
T_1	= Preheating temperature = 60...70 °C
T_0	= Ambient temperature [°C]
m_{eng}	= Engine weight [tonne]
V_{LO}	= Lubricating oil volume [m ³] (wet sump engines only)
V_{FW}	= HT water volume [m ³]
t	= Preheating time [h]
k_{eng}	= Engine specific coefficient = 0.5 kW
n_{cyl}	= Number of cylinders

The formula above should not be used for $P < 2$ kW/cyl

9.3.9.2 Circulation pump for HT preheater (4P04)

Design data:

Capacity	0.3 m ³ /h per cylinder
Delivery pressure	80...100 kPa (0.8...1.0 bar)

9.3.9.3 Preheating unit (4N01)

A complete preheating unit can be supplied. The unit comprises:

- Electric or steam heaters
- Circulating pump
- Control cabinet for heaters and pump
- Set of thermometers
- Non-return valve
- Safety valve

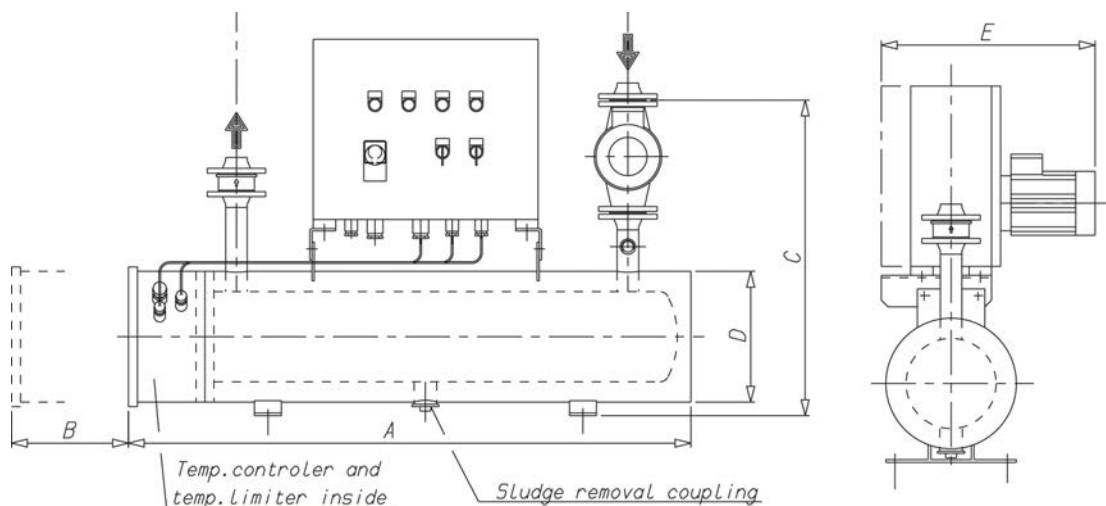

Fig 9-10 Preheating unit, electric (V60L0653A)

Heater capacity	Pump capacity	Weight	Pipe connections	Dimensions				
kW	m ³ / h	kg	Inlet / Outlet	A	B	C	D	E
7.5	3	75	DN40	1050	720	610	190	425
12	3	93	DN40	1050	550	660	240	450
15	3	93	DN40	1050	720	660	240	450
18	3	95	DN40	1250	900	660	240	450
22.5	8	100	DN40	1050	720	700	290	475
27	8	103	DN40	1250	900	700	290	475
30	8	105	DN40	1050	720	700	290	475
36	8	125	DN40	1250	900	700	290	475
45	8	145	DN40	1250	720	755	350	505
54	8	150	DN40	1250	900	755	350	505

9.3.10 Throttles

Throttles (orifices) are to be installed in all by-pass lines to ensure balanced operating conditions for temperature control valves. Throttles must also be installed wherever it is necessary to balance the waterflow between alternate flow paths.

9.3.11 Thermometers and pressure gauges

Local thermometers should be installed wherever there is a temperature change, i.e. before and after heat exchangers etc. in external system.

Local pressure gauges should be installed on the suction and discharge side of each pump.

This page intentionally left blank

10. Combustion Air System

10.1 Engine room ventilation

To maintain acceptable operating conditions for the engines and to ensure trouble free operation of all equipment, attention shall be paid to the engine room ventilation and the supply of combustion air.

The air intakes to the engine room must be located and designed so that water spray, rain water, dust and exhaust gases cannot enter the ventilation ducts and the engine room.

The dimensioning of blowers and extractors should ensure that an overpressure of about 50 Pa is maintained in the engine room in all running conditions.

For the minimum requirements concerning the engine room ventilation and more details, see applicable standards, such as ISO 8861.

The amount of air required for ventilation is calculated from the total heat emission Φ to evacuate. To determine Φ , all heat sources shall be considered, e.g.:

- Main and auxiliary diesel engines
- Exhaust gas piping
- Generators
- Electric appliances and lighting
- Boilers
- Steam and condensate piping
- Tanks

It is recommended to consider an outside air temperature of no less than 35°C and a temperature rise of 11°C for the ventilation air.

The amount of air required for ventilation is then calculated using the formula:

$$q_v = \frac{\Phi}{\rho \times c \times \Delta T}$$

where:

Q_v = air flow [m³/s]

Φ = total heat emission to be evacuated [kW]

ρ = air density 1.13 kg/m³

c = specific heat capacity of the ventilation air 1.01 kJ/kgK

ΔT = temperature rise in the engine room [°C]

The heat emitted by the engine is listed in chapter *Technical data*.

The engine room ventilation air has to be provided by separate ventilation fans. These fans should preferably have two-speed electric motors (or variable speed). The ventilation can then be reduced according to outside air temperature and heat generation in the engine room, for example during overhaul of the main engine when it is not preheated (and therefore not heating the room).

The ventilation air is to be equally distributed in the engine room considering air flows from points of delivery towards the exits. This is usually done so that the funnel serves as exit for most of the air. To avoid stagnant air, extractors can be used.

It is good practice to provide areas with significant heat sources, such as separator rooms with their own air supply and extractors.

Under-cooling of the engine room should be avoided during all conditions (service conditions, slow steaming and in port). Cold draft in the engine room should also be avoided, especially in areas of frequent maintenance activities. For very cold conditions a pre-heater in the system should be considered. Suitable media could be thermal oil or water/glycol to avoid the risk for freezing. If steam is specified as heating medium for the ship, the pre-heater should be in a secondary circuit.

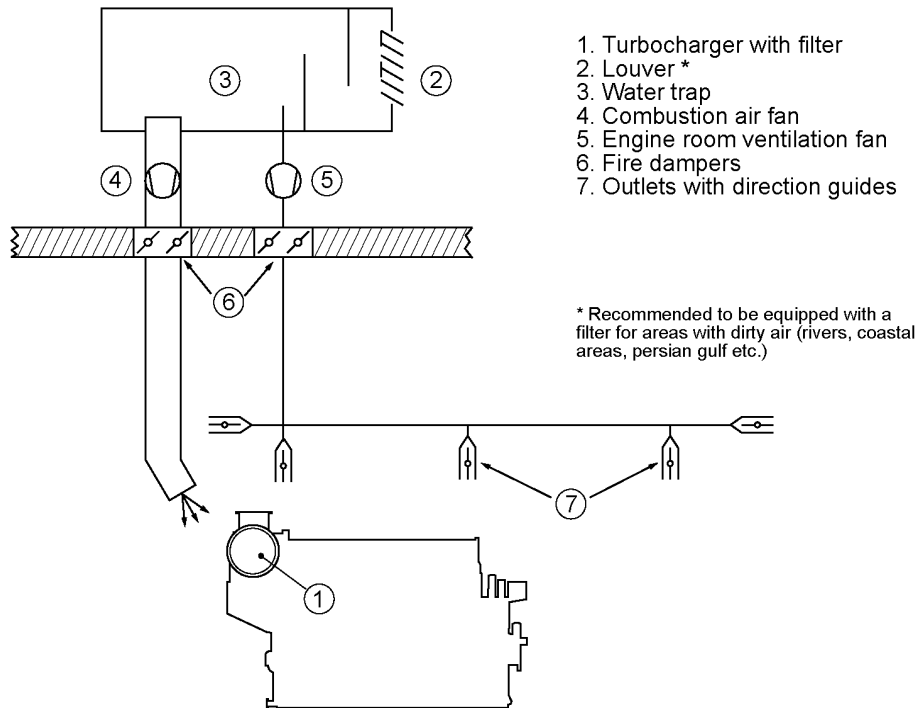

Fig 10-1 Engine room ventilation, turbocharger with air filter (DAAE092651)

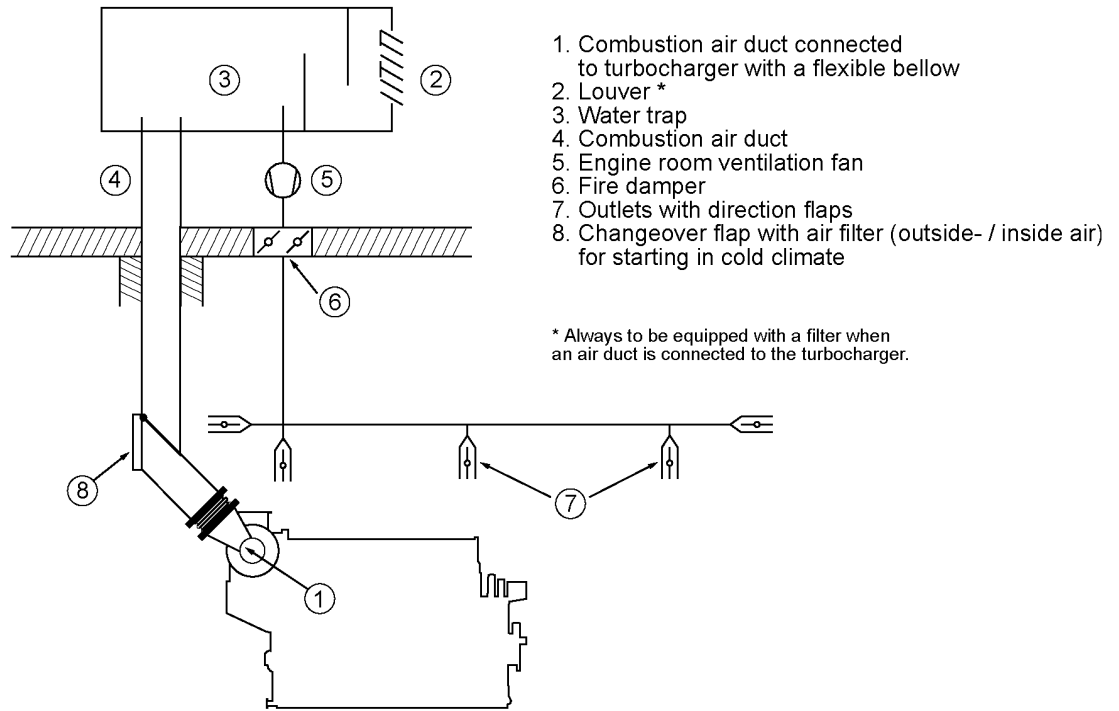

Fig 10-2 Engine room ventilation, air duct connected to the turbocharger (DAAE092652A)

10.2 Combustion air system design

Usually, the combustion air is taken from the engine room through a filter on the turbocharger. This reduces the risk for too low temperatures and contamination of the combustion air. It is important that the combustion air is free from sea water, dust, fumes, etc.

For the required amount of combustion air, see section *Technical data*.

The combustion air shall be supplied by separate combustion air fans, with a capacity slightly higher than the maximum air consumption. The combustion air mass flow stated in technical data is defined for an ambient air temperature of 25°C. Calculate with an air density corresponding to 30°C or more when translating the mass flow into volume flow. The expression below can be used to calculate the volume flow.

$$q_c = \frac{m'}{\rho}$$

where:

q_c = combustion air volume flow [m³/s]

m' = combustion air mass flow [kg/s]

ρ = air density 1.15 kg/m³

The fans should preferably have two-speed electric motors (or variable speed) for enhanced flexibility. In addition to manual control, the fan speed can be controlled by engine load.

In multi-engine installations each main engine should preferably have its own combustion air fan. Thus the air flow can be adapted to the number of engines in operation.

The combustion air should be delivered through a dedicated duct close to the turbocharger, directed towards the turbocharger air intake. The outlet of the duct should be equipped with

a flap for controlling the direction and amount of air. Also other combustion air consumers, for example other engines, gas turbines and boilers shall be served by dedicated combustion air ducts.

If necessary, the combustion air duct can be connected directly to the turbocharger with a flexible connection piece. With this arrangement an external filter must be installed in the duct to protect the turbocharger and prevent fouling of the charge air cooler. The permissible total pressure drop in the duct is max. 1.5 kPa. The duct should be provided with a step-less change-over flap to take the air from the engine room or from outside depending on engine load and air temperature.

For very cold conditions arctic setup is to be used. The combustion air fan is stopped during start of the engine and the necessary combustion air is drawn from the engine room. After start either the ventilation air supply, or the combustion air supply, or both in combination must be able to maintain the minimum required combustion air temperature. The air supply from the combustion air fan is to be directed away from the engine, when the intake air is cold, so that the air is allowed to heat up in the engine room.

10.2.1 Charge air shut-off valve (optional)

In installations where it is possible that the combustion air includes combustible gas or vapour the engines can be equipped with charge air shut-off valve. This is regulated mandatory where ingestion of flammable gas or fume is possible.

10.2.2 Condensation in charge air coolers

Air humidity may condense in the charge air cooler, especially in tropical conditions. The engine equipped with a small drain pipe from the charge air cooler for condensed water.

The amount of condensed water can be estimated with the diagram below.

Example, according to the diagram:

At an ambient air temperature of 35°C and a relative humidity of 80%, the content of water in the air is 0.029 kg water/ kg dry air. If the air manifold pressure (receiver pressure) under these conditions is 2.5 bar (= 3.5 bar absolute), the dew point will be 55°C. If the air temperature in the air manifold is only 45°C, the air can only contain 0.018 kg/kg. The difference, 0.011 kg/kg (0.029 - 0.018) will appear as condensed water.

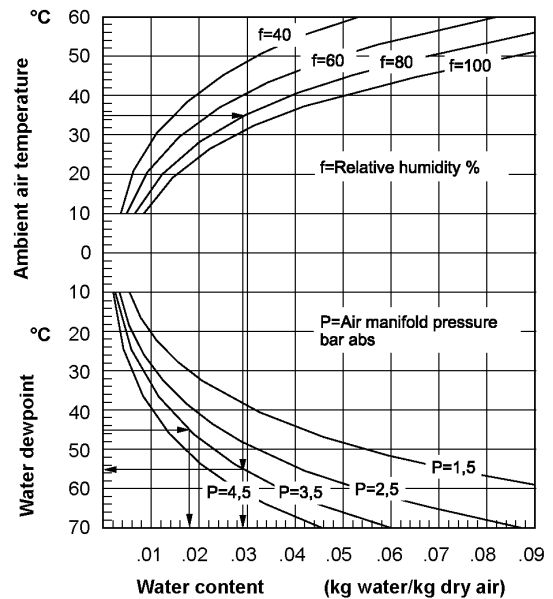

Fig 10-3 Condensation in charge air coolers

11. Exhaust Gas System

11.1 Internal exhaust gas system

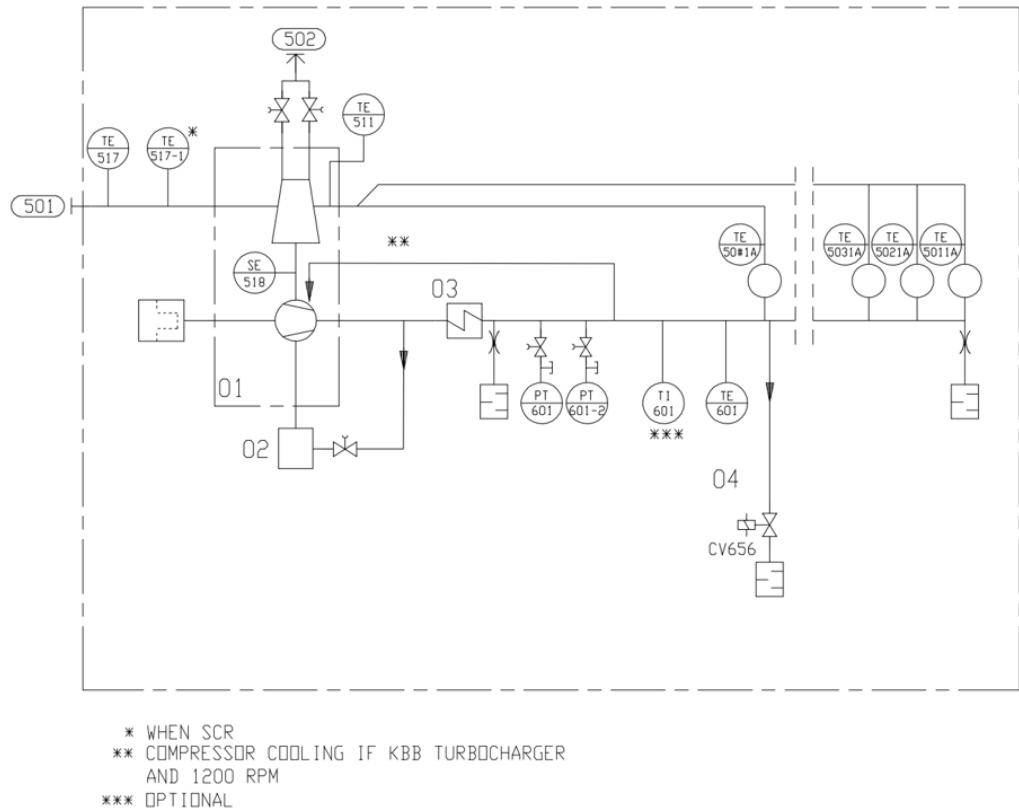

Fig 11-1 Internal exhaust gas system (DAAF382590D) - UNIC C1

System components:	
01	Turbocharger
02	Water container
03	Charge air cooler
04	Adjustable charge air wastegate

Sensors and indicators:			
TE50#1A	Exhaust gas temperature after each cylinder	PT601 - 2	Charge air pressure, engine inlet
TE511	Exhaust gas temperature, TC inlet	CV656	Air wastegate control
TE517	Exhaust gas temperature, TC outlet	*TE517 - 1	Exhaust gas temperature, TC outlet
SE518	Turbocharger speed	TE601	Charge air temperature, engine inlet
PT601	Charge air pressure, engine inlet	***TI601	Charge air temperature, engine inlet (optional)

Pipe connections		Size
501	Exhaust gas outlet	4L: DN200 6L: DN250 8L: DN250, DN300 9L: DN300
502	Cleaning water to turbine	OD15

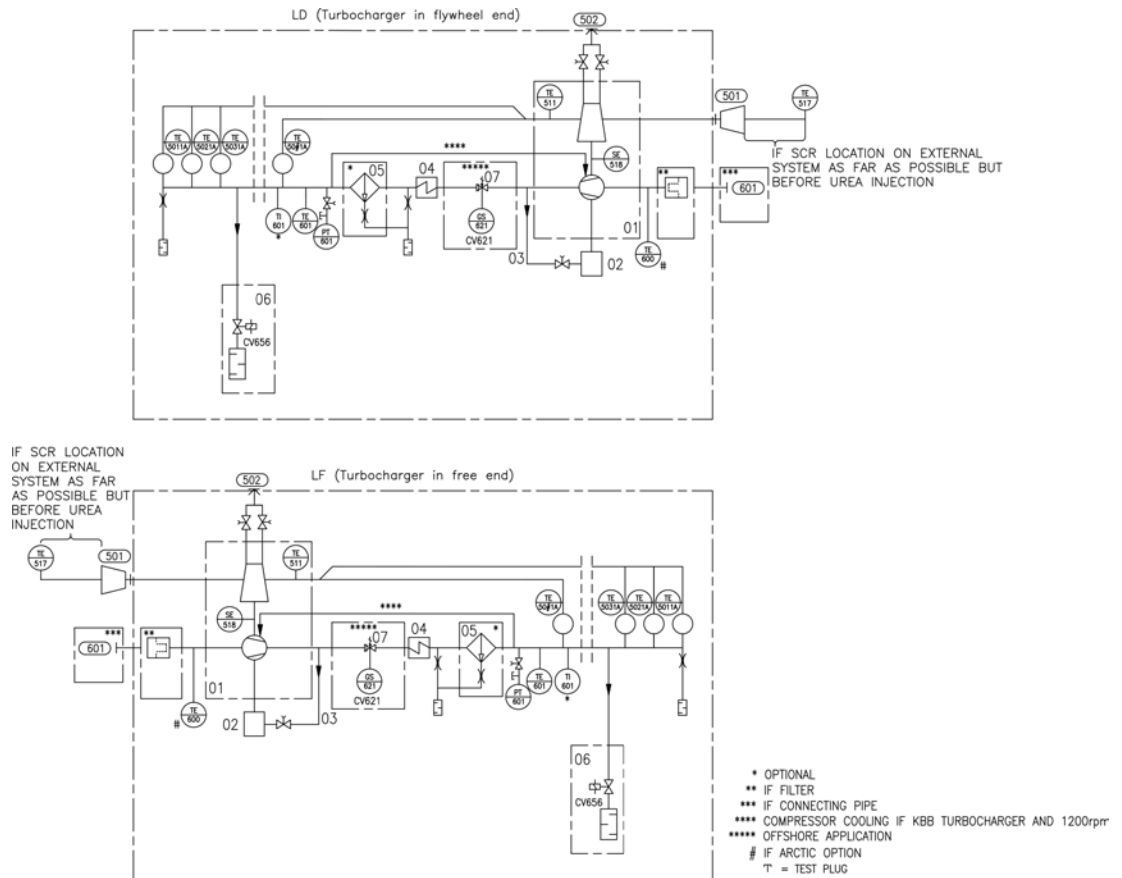

Fig 11-2 Internal exhaust gas system (DAAF395505C) - UNIC C2 & UNIC 2.0

System components:			
01	Turbocharger	05	Water mist separator
02	Water container	06	Adjustable charge air wastegate
03	Pressure from air duct	07	Charge air shut-off valve
04	Charge air cooler		

Sensors and indicators:			
TE50#1A	Exhaust gas temperature after each cylinder	TE600	Air temperature, TC inlet (if Arctic option)
TE511	Exhaust gas temperature, TC inlet	CV621	Charge air shut-off valve control
TE517	Exhaust gas temperature, TC outlet	GS621	Charge air shut-off valve position
SE518	TC speed	TE601	Charge air temperature, engine inlet
PT601	Charge air pressure, engine inlet	TI601	Charge air temperature, engine inlet (optional)
CV656	Air wastegate control		

Pipe connections		Size
501	Exhaust gas outlet	4L: DN200 6L: DN250 8L: DN250, DN300 9L: DN300
502	Cleaning water to turbine	OD15
601	Suction air inlet	as same as connecting pipe

11.2 Temperature sensor location after Turbocharger

For measuring the exhaust gases after the turbocharger, the engine is delivered with temperature sensor TE517. The sensor is located at the exhaust gas bend, which is mounted on the turbocharger. Measuring results from this sensor is used to alarm / trigger load reduction, if exhaust gasses are abnormal high. It is also used in exhaust gas temperature (t6) control functionality in the SCR installations.

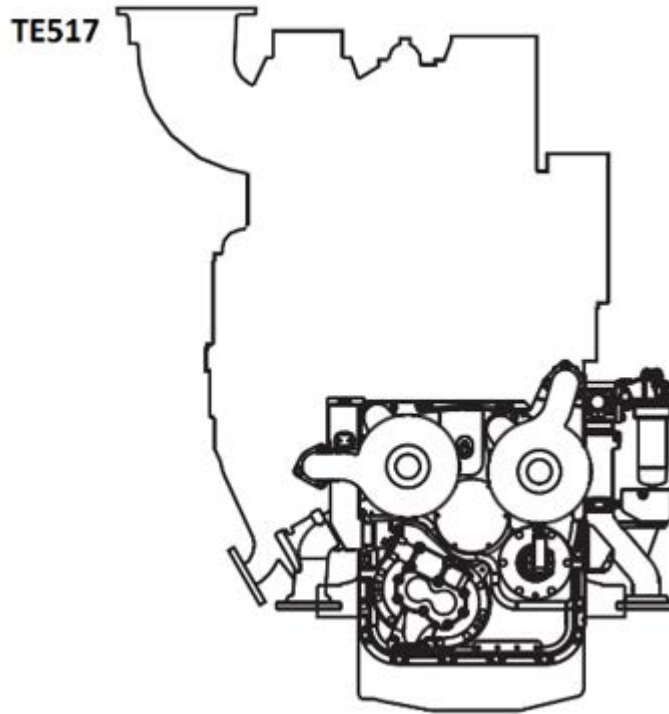

Fig 11-3 TE517 sensor location on turbocharger bend curve

To be noted in SCR installations

When urea injection is activated, urea water liquid and compressed air, which are colder than exhaust gasses, are mixed into the hot exhaust gasses in the mixing and injection unit. This endothermic reaction, which happens before SCR reactor, drops the exhaust gas temperature from the engine t6 set point with approx. 5-10 °C. This means that exhaust gas temperature just before the SCR reactor inlet is approx. 5-10 °C lower than temperature at TE517. Temperature drop is load and exhaust gas flow dependent. Largest temperature drop affect can therefore be seen on low engine loads, where urea injection ratio is higher compared to the decreased exhaust gas flow.

The exothermic chemical reaction that is taking place inside the SCR reactor, increases the exhaust gas temperature with approx. 10 °C. The exhaust gas temperature at SCR outlet is therefore approx. the same as at TE517 sensor location.

When urea is not injected, its cooling affect before catalyst elements is not seen. This means that SCR inlet and outlet temperatures should be even.

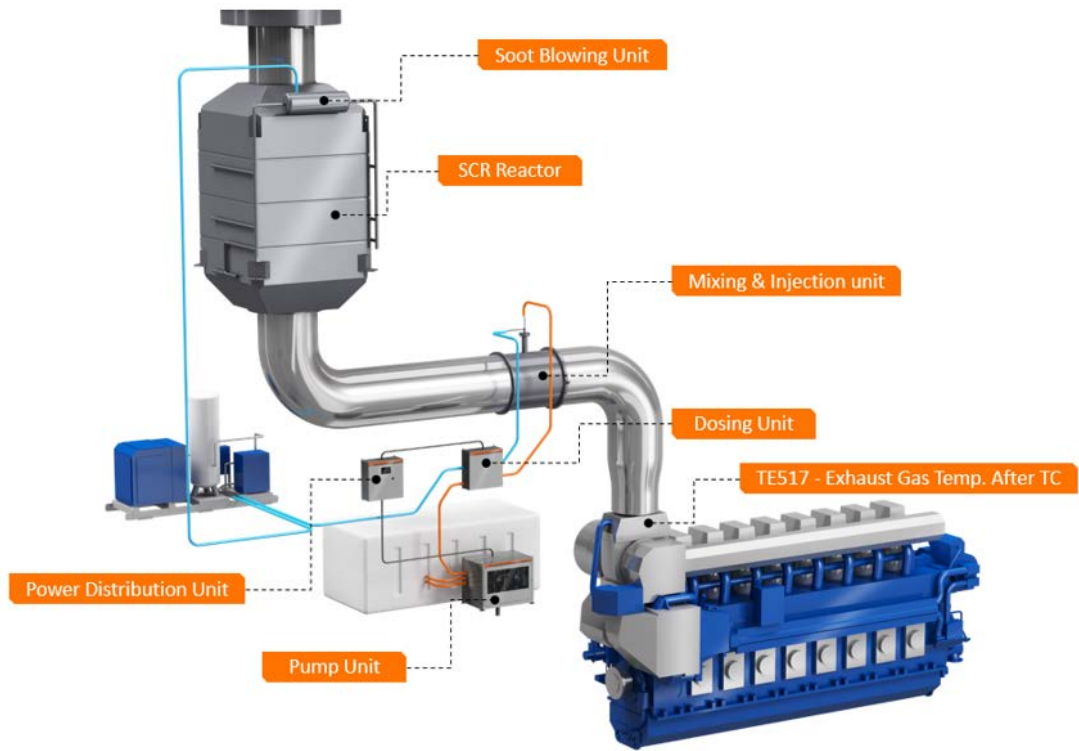
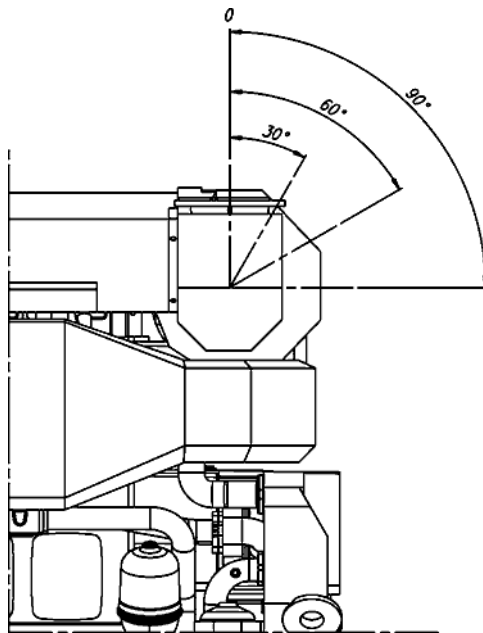

Fig 11-4 Principle layout of SCR (Wärtsilä NOR)

11.3 Exhaust gas outlet



Engine	TC in free end	TC in driving end
W 4L20	0°, 30°, 60°, 90°	-
W 6L20	0°, 30°, 60°, 90°	0°, 30°, 60°, 90°
W 8L20	0°, 30°, 60°, 90°	0°, 30°, 60°, 90°
W 9L20	0°, 30°, 60°, 90°	0°, 30°, 60°, 90°

Fig 11-5 Exhaust pipe connections (DAAE066842)

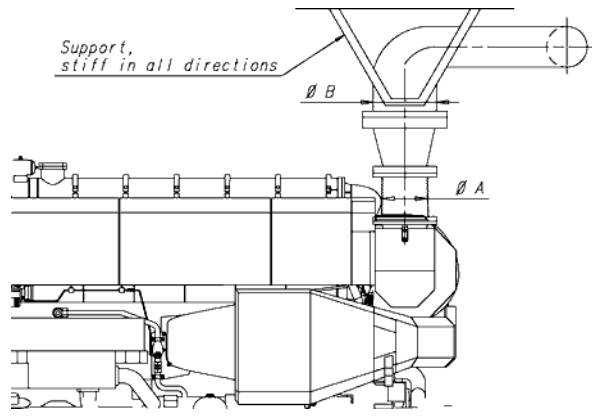

Engine	ØA [mm]	ØB [mm]
W 4L20	200	300
W 6L20	250	350 - 400
W 8L20	300	400 - 450
W 9L20	300	450

Fig 11-6 Exhaust pipe, diameters and support (DAAF014083)

11.4 External exhaust gas system

Each engine should have its own exhaust pipe into open air. Backpressure, thermal expansion and supporting are some of the decisive design factors.

Flexible bellows must be installed directly on the turbocharger outlet, to compensate for thermal expansion and prevent damages to the turbocharger due to vibrations.

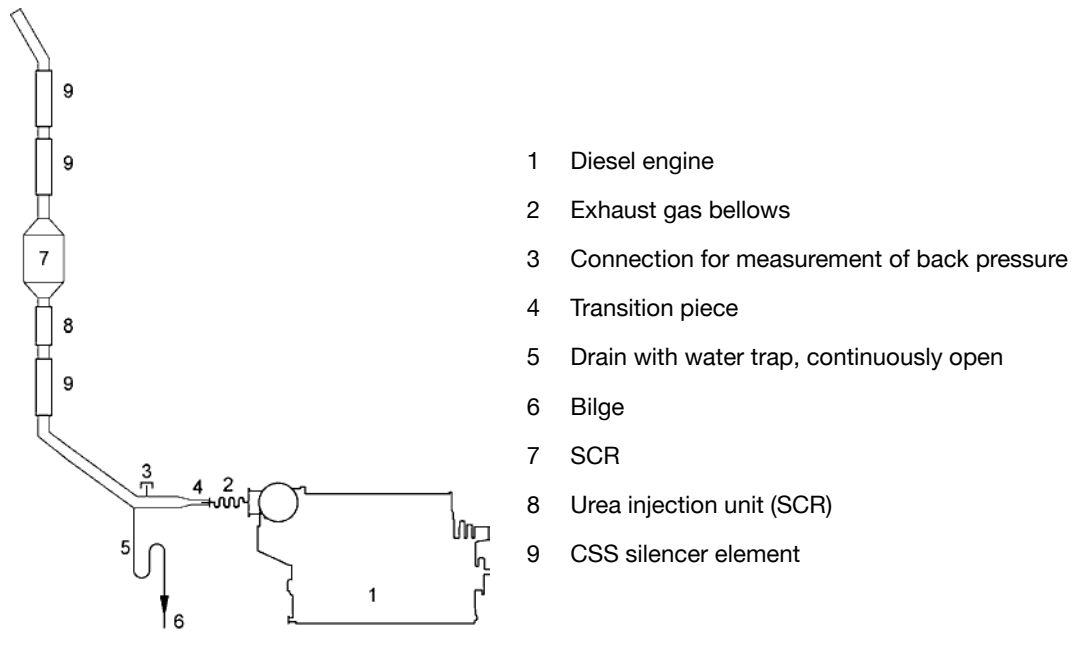

Fig 11-7 External exhaust gas system

11.4.1 Piping

The piping should be as short and straight as possible. Pipe bends and expansions should be smooth to minimise the backpressure. The diameter of the exhaust pipe should be increased directly after the bellows on the turbocharger. Pipe bends should be made with the largest possible bending radius; the bending radius should not be smaller than 1.5 x D.

The recommended flow velocity in the pipe is maximum 35...40 m/s at full output. If there are many resistance factors in the piping, or the pipe is very long, then the flow velocity needs to be lower. The exhaust gas mass flow given in chapter *Technical data* can be translated to velocity using the formula:

$$v = \frac{4 \times m'}{1.3 \times \left(\frac{273}{273 + T} \right) \times \pi \times D^2}$$

where:

v = gas velocity [m/s]

m' = exhaust gas mass flow [kg/s]

T = exhaust gas temperature [°C]

D = exhaust gas pipe diameter [m]

The exhaust pipe must be insulated with insulation material approved for concerned operation conditions, minimum thickness 30 mm considering the shape of engine mounted insulation. Insulation has to be continuous and protected by a covering plate or similar to keep the insulation intact.

Closest to the turbocharger the insulation should consist of a hook on padding to facilitate maintenance. It is especially important to prevent the airstream to the turbocharger from detaching insulation, which will clog the filters.

After the insulation work has been finished, it has to be verified that it fulfils SOLAS-regulations. Surface temperatures must be below 220°C on whole engine operating range.

11.4.2 Supporting

It is very important that the exhaust pipe is properly fixed to a support that is rigid in all directions directly after the bellows on the turbocharger. There should be a fixing point on both sides of the pipe at the support. The bellows on the turbocharger may not be used to absorb thermal expansion from the exhaust pipe. The first fixing point must direct the thermal expansion away from the engine. The following support must prevent the pipe from pivoting around the first fixing point.

Absolutely rigid mounting between the pipe and the support is recommended at the first fixing point after the turbocharger. Resilient mounts can be accepted for resiliently mounted engines with “double” variant bellows (bellow capable of handling the additional movement), provided that the mounts are self-captive; maximum deflection at total failure being less than 2 mm radial and 4 mm axial with regards to the bellows. The natural frequencies of the mounting should be on a safe distance from the running speed, the firing frequency of the engine and the blade passing frequency of the propeller. The resilient mounts can be rubber mounts of conical type, or high damping stainless steel wire pads. Adequate thermal insulation must be provided to protect rubber mounts from high temperatures. When using resilient mounting, the alignment of the exhaust bellows must be checked on a regular basis and corrected when necessary.

After the first fixing point resilient mounts are recommended. The mounting supports should be positioned at stiffened locations within the ship’s structure, e.g. deck levels, frame webs or specially constructed supports.

The supporting must allow thermal expansion and ship’s structural deflections.

11.4.3 Back pressure

The maximum permissible exhaust gas back pressure is stated in chapter *Technical Data*. The back pressure in the system must be calculated by the shipyard based on the actual piping design and the resistance of the components in the exhaust system. The exhaust gas mass flow and temperature given in chapter *Technical Data* may be used for the calculation.

Each exhaust pipe should be provided with a connection for measurement of the back pressure. The back pressure must be measured by the shipyard during the sea trial.

11.4.4 Exhaust gas bellows (5H01, 5H03)

Bellows must be used in the exhaust gas piping where thermal expansion or ship’s structural deflections have to be segregated. The flexible bellows mounted directly on the turbocharger outlet serves to minimise the external forces on the turbocharger and thus prevent excessive vibrations and possible damage. All exhaust gas bellows must be of an approved type.

11.4.5 SCR-unit (11N14)

The SCR-unit requires special arrangement on the engine in order to keep the exhaust gas temperature and backpressure into SCR-unit working range. The exhaust gas piping must be straight at least 3...5 meters in front of the SCR unit. If both an exhaust gas boiler and a SCR unit will be installed, then the exhaust gas boiler shall be installed after the SCR. Arrangements

must be made to ensure that water cannot spill down into the SCR, when the exhaust boiler is cleaned with water.

More information about the SCR-unit can be found in the *Wärtsilä Environmental Product Guide*.

11.4.6 Exhaust gas boiler

If exhaust gas boilers are installed, each engine should have a separate exhaust gas boiler. Alternatively, a common boiler with separate gas sections for each engine is acceptable.

For dimensioning the boiler, the exhaust gas quantities and temperatures given in chapter *Technical data* may be used.

11.4.7 Exhaust gas silencers

The exhaust gas silencing can be accomplished either by the patented Compact Silencer System (CSS) technology or by the conventional exhaust gas silencer.

11.4.7.1 Exhaust noise

The unattenuated exhaust noise is typically measured in the exhaust duct. The in-duct measurement is transformed into free field sound power through a number of correction factors.

The spectrum of the required attenuation in the exhaust system is achieved when the free field sound power (A) is transferred into sound pressure (B) at a certain point and compared with the allowable sound pressure level (C).

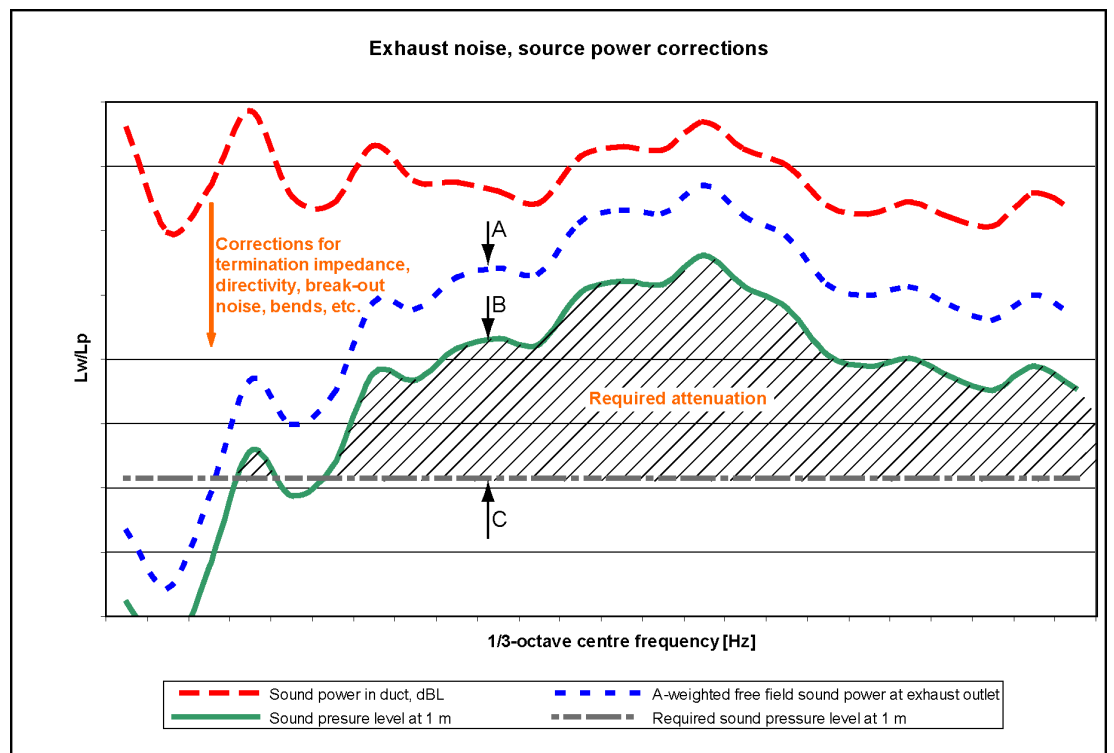

Fig 11-8 Exhaust noise, source power corrections

The conventional silencer is able to reduce the sound level in a certain area of the frequency spectrum. CSS is designed to cover the whole frequency spectrum.

11.4.7.2 Silencer system comparison

With a conventional silencer system, the design of the noise reduction system usually starts from the engine. With the CSS, the design is reversed, meaning that the noise level acceptability at a certain distance from the ship's exhaust gas pipe outlet, is used to dimension the noise reduction system.

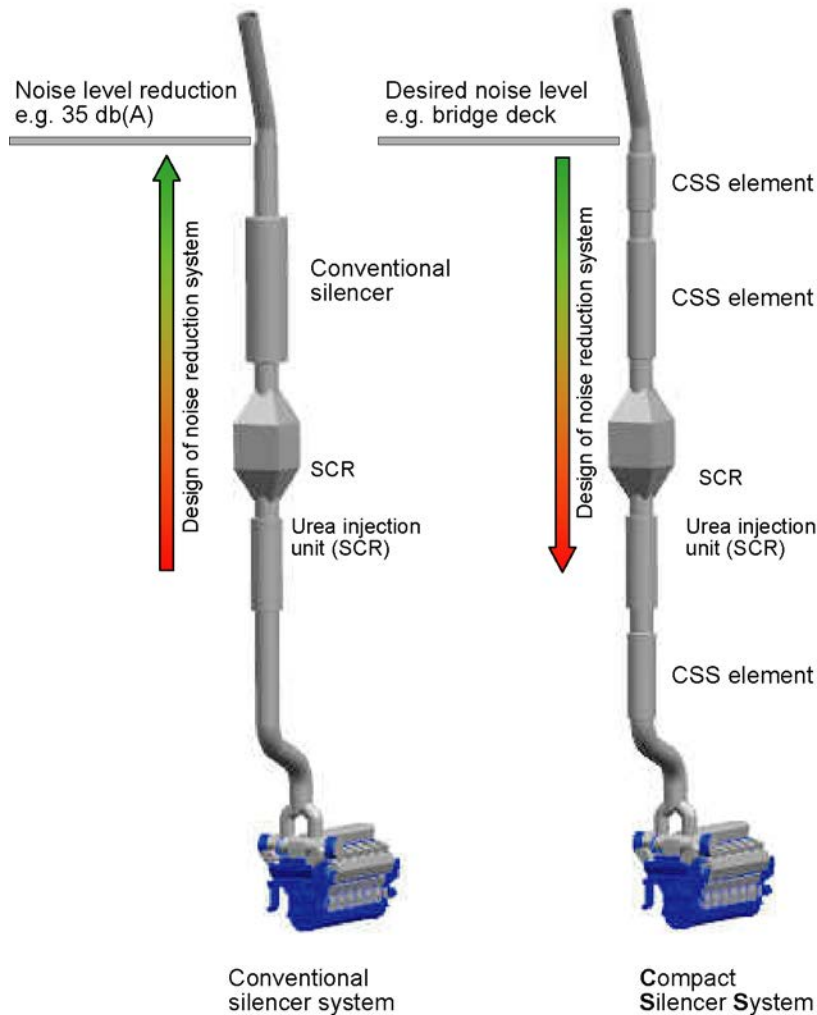

Fig 11-9 Silencer system comparison

11.4.7.3 Compact silencer system (5N02)

The CSS system is optimized for each installation as a complete exhaust gas system. The optimization is made according to the engine characteristics, to the sound level requirements and to other equipment installed in the exhaust gas system, like SCR, exhaust gas boiler or scrubbers.

The CSS system is built up of three different CSS elements; resistive, reactive and composite elements. The combination-, amount- and length of the elements are always installation specific. The diameter of the CSS element is 1.4 times the exhaust gas pipe diameter.

The noise attenuation is valid up to an exhaust gas flow velocity of max 40 m/s. The pressure drop of a CSS element is lower compared to a conventional exhaust gas silencer (5R02).

11.4.7.4 Conventional exhaust gas silencer (5R02)

Yard/designer should take into account that unfavourable layout of the exhaust system (length of straight parts in the exhaust system) might cause amplification of the exhaust noise between engine outlet and the silencer. Hence the attenuation of the silencer does not give any absolute guarantee for the noise level after the silencer.

When included in the scope of supply, the standard silencer is of the absorption type, equipped with a spark arrester. It is also provided with a soot collector and a condense drain, but it comes without mounting brackets and insulation. The silencer can be mounted either horizontally or vertically.

The noise attenuation of the standard silencer is either 25 or 35 dB(A). This attenuation is valid up to a flow velocity of max. 40 m/s.

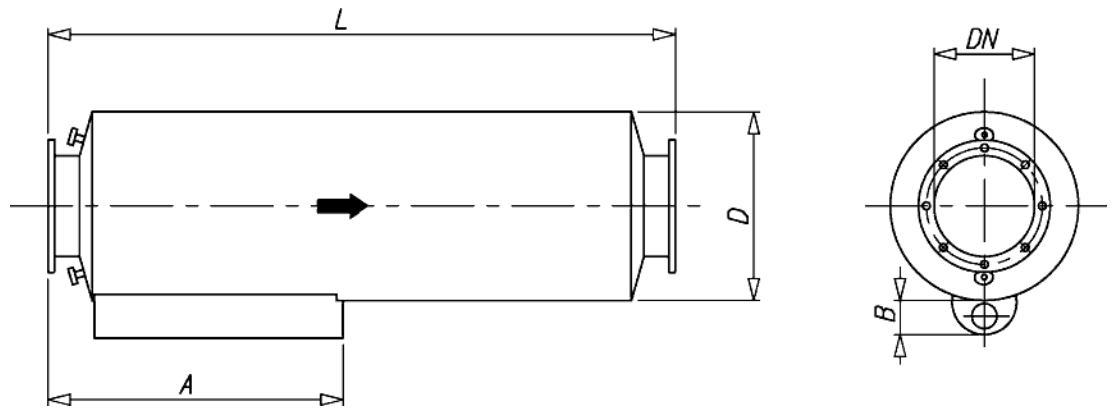

Fig 11-10 Exhaust gas silencer (V49E0137B)

Table 11-1 Typical dimensions of exhaust gas silencers

NS	D [mm]	A [mm]	B [mm]	Attenuation: 25 dB(A)		Attenuation: 35 dB(A)	
				L [mm]	Weight [kg]	L [mm]	Weight [kg]
300	860	1250	150	2530	360	3530	455
350	950	1405	115	2780	440	3780	580
400	1060	1500	150	3280	570	4280	710
450	1200	1700	180	3430	685	4280	855
500	1200	1700	200	3430	685	4280	860

Flanges: DIN 2501

This page intentionally left blank

12. Turbocharger Cleaning

Regular water cleaning of the turbine and the compressor reduces the formation of deposits and extends the time between overhauls. Fresh water is injected into the turbocharger during operation. Additives, solvents or salt water must not be used and the cleaning instructions in the operation manual must be carefully followed.

12.1 Turbine cleaning system

A dosing unit consisting of a flow meter and an adjustable throttle valve is delivered for each installation. The dosing unit is installed in the engine room and connected to the engine with a detachable rubber hose. The rubber hose is connected with quick couplings and the length of the hose is normally 10 m. One dosing unit can be used for several engines.

Water supply:

- Fresh water
- Min. pressure 0.3 MPa (3 bar)
- Max. pressure 2 MPa (20 bar)
- Max. temperature 80 °C
- Flow 6-10 l/min (depending on cylinder configuration)

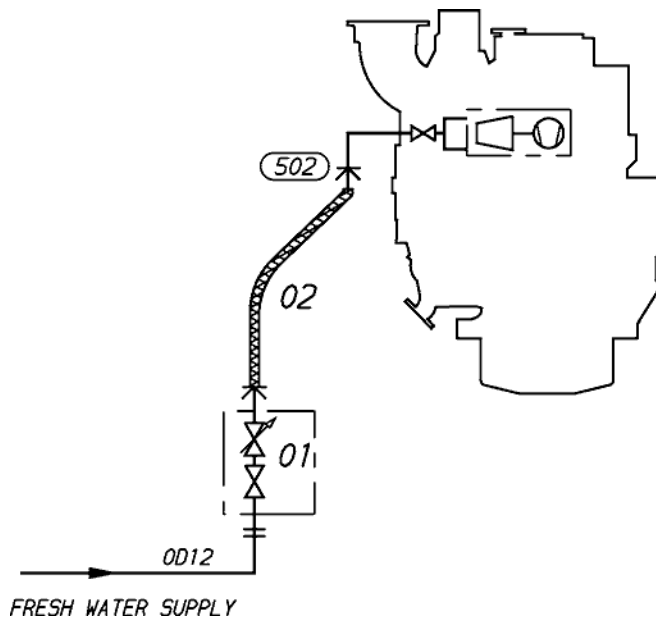

Fig 12-1 Turbine cleaning system (DAAE003884)

System components		Pipe connections		Size
01	Dosing unit with shut-off valve	502	Cleaning water to turbine	Quick coupling
02	Rubber hose			

12.2 Compressor cleaning system

The compressor side of the turbocharger is cleaned using a separate dosing vessel mounted on the engine.

This page intentionally left blank

13. Exhaust Emissions

Exhaust emissions from the diesel engine mainly consist of nitrogen, oxygen and combustion products like carbon dioxide (CO₂), water vapour and minor quantities of carbon monoxide (CO), sulphur oxides (SO_x), nitrogen oxides (NO_x), partially reacted and non-combusted hydrocarbons (HC) and particulate matter (PM).

There are different emission control methods depending on the aimed pollutant. These are mainly divided in two categories; primary methods that are applied on the engine itself and secondary methods that are applied on the exhaust gas stream.

13.1 Diesel engine exhaust components

The nitrogen and oxygen in the exhaust gas are the main components of the intake air which don't take part in the combustion process.

CO₂ and water are the main combustion products. Secondary combustion products are carbon monoxide, hydrocarbons, nitrogen oxides, sulphur oxides, soot and particulate matters.

In a diesel engine the emission of carbon monoxide and hydrocarbons are low compared to other internal combustion engines, thanks to the high air/fuel ratio in the combustion process. The air excess allows an almost complete combustion of the HC and oxidation of the CO to CO₂, hence their quantity in the exhaust gas stream are very low.

13.1.1 Nitrogen oxides (NO_x)

The combustion process gives secondary products as Nitrogen oxides. At high temperature the nitrogen, usually inert, react with oxygen to form Nitric oxide (NO) and Nitrogen dioxide (NO₂), which are usually grouped together as NO_x emissions. Their amount is strictly related to the combustion temperature.

NO can also be formed through oxidation of the nitrogen in fuel and through chemical reactions with fuel radicals. NO in the exhaust gas flow is in a high temperature and high oxygen concentration environment, hence oxidizes rapidly to NO₂. The amount of NO₂ emissions is approximately 5 % of total NO_x emissions.

13.1.2 Sulphur Oxides (SO_x)

Sulphur oxides (SO_x) are direct result of the sulphur content of the fuel oil. During the combustion process the fuel bound sulphur is rapidly oxidized to sulphur dioxide (SO₂). A small fraction of SO₂ may be further oxidized to sulphur trioxide (SO₃).

13.1.3 Particulate Matter (PM)

The particulate fraction of the exhaust emissions represents a complex mixture of inorganic and organic substances mainly comprising soot (elemental carbon), fuel oil ash (together with sulphates and associated water), nitrates, carbonates and a variety of non or partially combusted hydrocarbon components of the fuel and lubricating oil.

13.1.4 Smoke

Although smoke is usually the visible indication of particulates in the exhaust, the correlations between particulate emissions and smoke is not fixed. The lighter and more volatile hydrocarbons will not be visible nor will the particulates emitted from a well maintained and operated diesel engine.

Smoke can be black, blue, white, yellow or brown in appearance. Black smoke is mainly comprised of carbon particulates (soot). Blue smoke indicates the presence of the products

of the incomplete combustion of the fuel or lubricating oil. White smoke is usually condensed water vapour. Yellow smoke is caused by NO_x emissions. When the exhaust gas is cooled significantly prior to discharge to the atmosphere, the condensed NO₂ component can have a brown appearance.

13.2 Marine exhaust emissions legislation

13.2.1 International Maritime Organization (IMO)

The increasing concern over the air pollution has resulted in the introduction of exhaust emission controls to the marine industry. To avoid the growth of uncoordinated regulations, the IMO (International Maritime Organization) has developed the Annex VI of MARPOL 73/78, which represents the first set of regulations on the marine exhaust emissions.

The IMO Tier 3 NO_x emission standard will enter into force from year 2016. It will by then apply for new marine diesel engines that:

- Are > 130 kW
- Installed in ships which keel laying date is 1.1.2016 or later
- Operating inside the North American ECA and the US Caribbean Sea ECA

From 1.1.2021 onwards Baltic sea and North sea will be included in to IMO Tier 3 NO_x requirements.

13.2.2 Other Legislations

There are also other local legislations in force in particular regions.

13.3 Methods to reduce exhaust emissions

All standard Wärtsilä engines meet the NO_x emission level set by the IMO (International Maritime Organisation) and most of the local emission levels without any modifications. Wärtsilä has also developed solutions to significantly reduce NO_x emissions when this is required.

Diesel engine exhaust emissions can be reduced either with primary or secondary methods. The primary methods limit the formation of specific emissions during the combustion process. The secondary methods reduce emission components after formation as they pass through the exhaust gas system.

Refer to the "*Wärtsilä Environmental Product Guide*" for information about exhaust gas emission control systems.

14. Automation System

The engine can be equipped with different automation system, depending on configuration.

14.1 UNIC C1

14.1.1 System overview

The auxiliary automation system consists of a built-on control system for control of the running parameters, monitoring of the safety sensors and automatic safety operations.

14.1.2 Automation system scope

The engine mounted equipment mainly consists of :

- Main control unit (MCM) for control of starting and stopping sequences and speed control of the generating set.
- Engine safety module (ESM) for measuring of engine speed and turbocharger speed and for activation of automatic safety shutdowns (over speed, low lubricating oil pressure and high HT cooling water temperature. The ESM also performs wire break monitoring for the safety system signals.
- Electric actuator for control of fuel rack position.
- Solenoids
- Sensors and switches for the ships alarm and monitoring system. The sensors are pre-wired to a connection box on the generating set.
- Indicators for generating set speed, turbocharger speed and running hours.
- Local indications (bar graphs) for engine main parameters.
- Control mode switch Blow / Blocked / Local / Remote
- Emergency stop button
- Local start button
- Local stop button
- Shutdown reset button

14.1.3 Power supply

The power supply requirement for the auxiliary generating sets is 24 VDC, 5A at steady state, and up to 20A for peaks (5 sec). UPS backed power supply is recommended. The control system is designed so that a redundant power supply system can be adopted.

14.1.4 Safety System

The safety system is an independent system continuously monitoring the required parameters for safe operation and performing shutdown of the generating set if the operating parameters exceed preset limits. The parameters monitored are:

- Overspeed
- Low lubricating oil pressure
- High HT cooling water temperature
- Emergency stop button

14.1.5 Start and stop system

The generating set is equipped with a built-on start and stop system for control of starting and stopping sequences as well as start blocking functions.

14.1.5.1 Start blocking

Starting is inhibited by the following functions:

- Turning device engaged.
- Pre-lubricating pressure low. Starting is allowed within 30 minutes after the pressure has dropped below the set point of 50 kPa.
- Engine start blocking selector switch turned into “Blocked” position
- Engine running
- Stop signal to engine activated (safety shut-down, emergency stop, normal stop)
- Stop lever in stop position

14.1.6 Speed control

The generating sets are provided with a built-on electronic speed control system and an actuator. The system is designed for maximum reliability and optimum performance.

The speed measuring is performed with redundant speed pick-ups and failure of one speed pick-up will not cause interference in the operation.

The speed control system has an integrated start fuel limiter for minimising smoke emission during the acceleration period when starting an engine.

The dynamic response can be adjusted and optimised for the particular installation.

The speed control is set up for speed droop control mode operation and the speed droop is factory adjusted for 4% at rated load. This is to ensure proper load sharing between paralleling units. To compensate for the speed decrease of the plant when the load increases, and vice versa when the load decreases, the ship should have a load sharing system with an outer (cascade) loop to correct for the frequency drift.

14.1.7 Sensors and signals

14.1.7.1 Local instrumentation

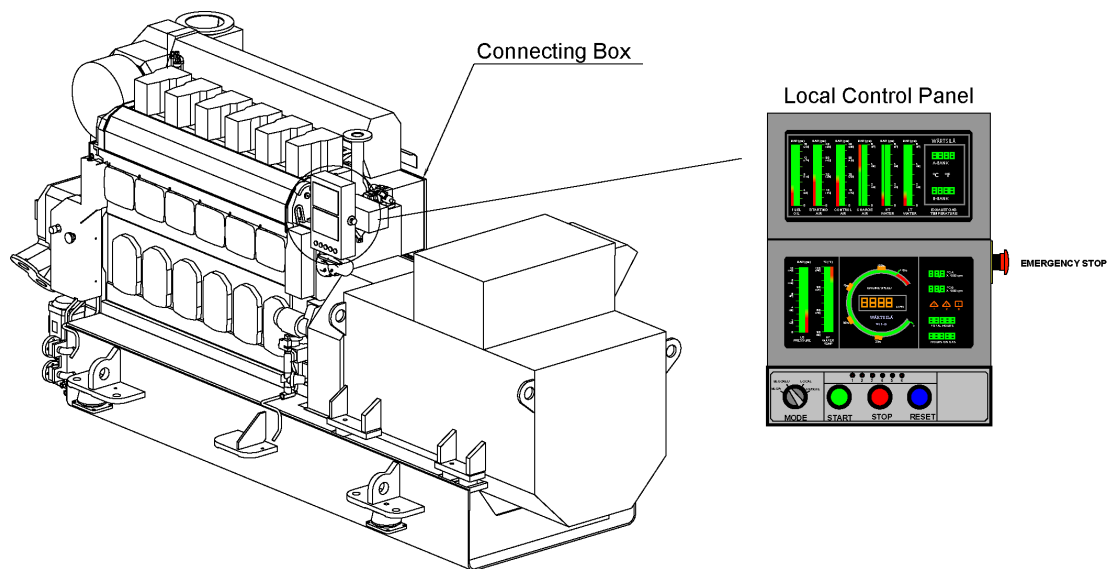

Fig 14-1 Connecting box and Local control panel

Thermometers

The generating set is as standard equipped with a bar graph type thermometer for HT cooling water temperature mounted in the local control box.

Pressure gauges

The generating set is as standard equipped with the following bar graph type pressure gauges:

- Fuel pressure
- Lubricating oil pressure
- Starting air pressure
- Control air pressure
- HT cooling water pressure
- LT cooling water pressure
- Charge air pressure

Indication of rpm

The generating sets are equipped with local indication for engine speed and turbocharger speed.

Generating set instrumentation

The generating sets are equipped with instrumentation for safety shutdowns and monitoring of various parameters.

Table 14-1 Engine to alarm system

Code	Description	I/O type	Signal type	Range	Alarm set-point	Delay	Note
PT101	Fuel Oil Pressure, Engine inlet	AI	4-20 mA	0-16 bar	< 4	5 s	
TE101	Fuel Oil Temperature, Engine inlet	AI	PT100	0-160°C			
LS103A	Fuel Oil Leakage, Injection Pipe	DI	Pot. free	on/off	OPEN	5 s	
PT201	Lubricating Oil Pressure, Engine inlet	AI	4-20 mA	0-10 bar	< 3	5 s	BL
TE201	Lubricating Oil Temperature, Engine inlet	AI	PT100	0-160°C	> 75	5 s	
PDS243	Lubricating Oil Filter Pressure Difference	DI	Pot. free	on/off	OPEN	5 s	Setpoint in sensor >1.5 bar
LS204	Lubricating oil low level, oil sump	DI	Pot. free	on/off	OPEN	5 s	
LS205	Lubricating oil high level, oil sump	DI	Pot. free	on/off	OPEN	5 s	Optional
PT301	Starting Air Pressure, Engine inlet	AI	4-20 mA	0-16 bar	< 7 > 15	15/5 s	
PT311	Control Air Pressure, Engine inlet	AI	4-20 mA	0-40 bar	< 16	5 s	
PT401	HT Water Pressure, Jacket inlet	AI	4-20 mA	0-6 bar	< 2	5 s	BL
TE401	HT Water Temperature, Jacket inlet	AI	PT100	0-160°C	< 60	5 s	
TE402	HT Water Temperature, Engine outlet	AI	PT100	0-160°C	> 105	5 s	
PT471	LT Water Pressure, CAC inlet	AI	4-20 mA	0-6 bar	< 2	2 s	BL
TE471	LT Water Temperature, CAC inlet	AI	PT100	0-160°C	> 55	5 s	
TE5011A- TE50X1A	Exhaust Gas Temperature, Cylinder X outlet	AI	4-20 mA	0-750°C	> 480	10 s	One sensor / cylinder. See Note 1)
TE517	Exhaust Gas Temperature, TC outlet	AI	4-20 mA	0-750°C	> 450	2 s	
PT601	Charge Air Pressure, Engine inlet	AI	4-20 mA	0-6 bar	> 3.7	25 s	
TE601	Charge Air Temperature, Engine inlet	AI	PT100	0-160°C	> 70	5 s	
ST173	Engine Speed	AI	4-20 mA	0-1200 rpm			
SE518	Turbo speed	AI	4-20 mA	0-75000 rpm	See table 14-2	5 s	
IS875	Start Failure	DI	Pot. free	on/off	OPEN	2 s	
IS1741/ IS1742	Overspeed, shutdown	DI	Pot. free	on/off	OPEN	2 s	Setpoint in ESM: >115%
IS4011	HT-Water Temperature High, Shutdown	DI	Pot. free	on/off	OPEN	2 s	Setpoint in ESM: >110°C
IS2011	Lubricating Oil Pressure Low, Shutdown	DI	Pot. free	on/off	OPEN	2 s	Setpoint in ESM: <2.0bar

Code	Description	I/O type	Signal type	Range	Alarm set-point	Delay	Note
NS161	Actuator major failure, Shutdown	DI	Pot. free	on/off	OPEN	2 s	
IS7305	Emergency Stop	DI	Pot. free	on/off	OPEN	2 s	
NS881	Engine Control System Minor Alarm	DI	Pot. free	on/off	OPEN	2 s	
NS718	ESM failure	DI	Pot. free	on/off	OPEN	2 s	
NS7799-1	PDM System Supply Earth Fault	DI	Pot. free	on/off	OPEN	2 s	
NS7800-1	PDM System Supply Failure	DI	Pot. free	on/off	OPEN	2 s	
NS869	WIP Failure	DI	Pot. free	on/off	OPEN	2 s	
OS820/ NS886	Engine Control System Major Failure	DI	Pot. free	on/off	OPEN	2 s	
IS780	Alarm Blocking	DI	Pot. free	on/off	CLOSED	2 s	Blocking all alarms marked with BL

Table 14-2 Alarm setpoint for SE518 Turbo speed

Engine	TC speed high alarm
4L20	60850 rpm
6L20	48000 rpm
8L20	41500 rpm
9L20	41500 rpm

Table 14-3 Generator to alarm system

Code	Description	I/O type	Signal type	Range	Alarm set-point	Delay	Note
TE7501	Bearing Temperature, DE	AI	PT100	0-160°C	> 85	2 s	If two bearing
TE7502	Bearing Temperature, NDE	AI	PT100	0-160°C	> 85	2 s	
TE7503	Winding Temperature, L1	AI	PT100	0-160°C	> 155	2 s	
TE7504	Winding Temperature, L2	AI	PT100	0-160°C	> 155	2 s	
TE7505	Winding Temperature, L3	AI	PT100	0-160°C	> 155	2 s	
TE75??	Air Temperature, Cooler Inlet	AI	PT100	0-160°C	> 75	2 s	If water cooled
LS7506	Cooling Water Leakage 1	DI	Pot. free	on/off	OPEN	2 s	If water cooled

Note 1) Alarm when exhaust gas temperature deviation $>\pm 100^{\circ}\text{C}/>\pm 50^{\circ}\text{C}$ from average when average temperature is $250/450^{\circ}\text{C}$. Deviation alarm to be blocked when average temperature $<250^{\circ}\text{C}$.

14.1.8 Control of auxiliary equipment

14.1.8.1 Pre-lubricating oil pump

The engine is equipped with an electric pre-lubricating pump.

The pre-lubricating pump is used for filling of the lubricating oil system, pre-lubricate a stopped engine before start and for pre-heating by circulating warm lubricating oil. The colder the engine is, the earlier the pump should be started before the engine is started.

The pump may also be run continuously when the engine is stopped and must run in multiple engine installations when other engines are running.

To ensure continuous pre-lubrication of a stopped engine, automatic starting and stopping of the pre-lubricating pump is recommended. This can be achieved using the pre-lubricating oil pump control output in the engine control system.

The generating sets can be supplied (option) with a pre-lubrication pump starter box. The starter is of bulkhead mount type with a starter contactor, overload protection and control system for the pump. The starters have indicating lights for power on, pump running and pump failure as well as a control switch for automatic or manual operation. The starter box can control pre-lubrication pumps of up to 4 generating sets.

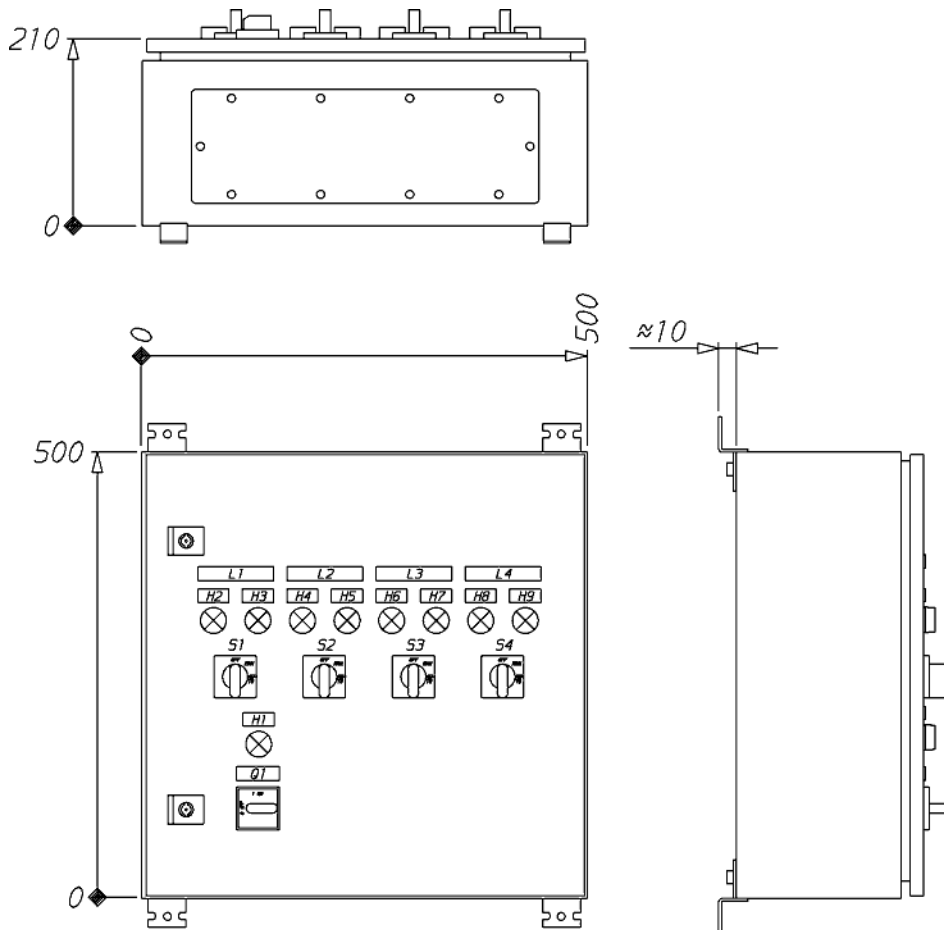

Fig 14-2 Pre-lubricating pump starter (DAAE005967A)

Technical data of pre-lubrication pumps:

WA20
400V / 50Hz 3.0kW, In = 6.0A

WA20
440V / 60 Hz 3.7kW In = 6.2A

14.1.8.2 Cooling water pre-heater and circulation pump

Pre-heating is done by an electric or steam pre-heater with a required heating power depending of the engine type. The temperature control of the pre-heater should be made automatic with a control thermostat. The heater and the circulation pump should be controlled from the pre-heater control output in the engine control system. For pre-heating unit see section "Pre-heating" in chapter "Cooling Water System".

14.2 UNIC C2

UNIC C2 is a fully embedded and distributed engine management system, which handles all control functions on the engine; for example start sequencing, start blocking, speed control, load sharing, normal stops and safety shutdowns.

The distributed modules communicate over a CAN-bus. CAN is a communication bus specifically developed for compact local networks, where high speed data transfer and safety are of utmost importance.

The CAN-bus and the power supply to each module are both physically doubled on the engine for full redundancy.

Control signals to/from external systems are hardwired to the terminals in the main cabinet on the engine. Process data for alarm and monitoring are communicated over a Modbus TCP connection to external systems.

Alternatively modbus RTU serial line RS-485 is also available.

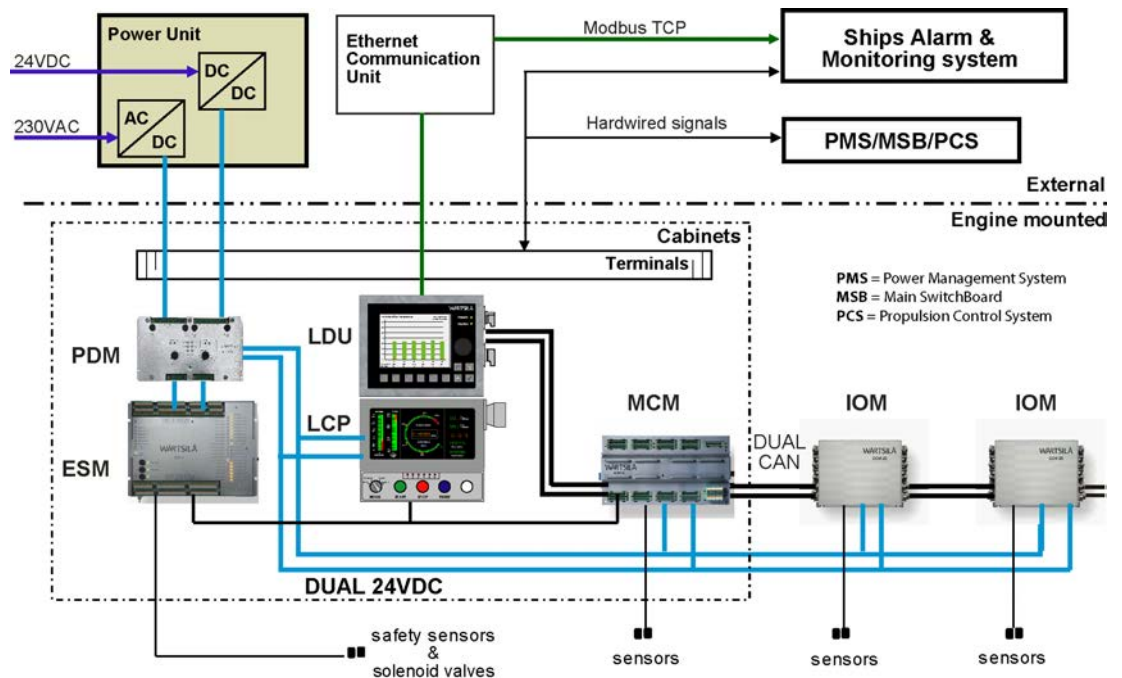

Fig 14-3 Architecture of UNIC C2

Short explanation of the modules used in the system:

MCM Main Control Module. Handles all strategic control functions (such as start/stop sequencing and speed/load control) of the engine.

ESM	Engine Safety Module handles fundamental engine safety, for example shutdown due to overspeed or low lubricating oil pressure.
LCP	Local Control Panel is equipped with push buttons and switches for local engine control, as well as indication of running hours and safety-critical operating parameters.
LDU	Local Display Unit offers a set of menus for retrieval and graphical display of operating data, calculated data and event history. The module also handles communication with external systems over Modbus TCP.
PDM	Power Distribution Module handles fusing, power distribution, earth fault monitoring and EMC filtration in the system. It provides two fully redundant supplies to all modules.
IOM	Input/Output Module handles measurements and limited control functions in a specific area on the engine.
CCM	Cylinder Control Module handles fuel injection control and local measurements for the cylinders.

The above equipment and instrumentation are prewired on the engine. The ingress protection class is IP54.

14.2.1 Local control panel and local display unit

Operational functions available at the LCP:

- Local start
- Local stop
- Local emergency speed setting selectors (mechanical propulsion):
 - Normal / emergency mode
 - Decrease / Increase speed
- Local emergency stop
- Local shutdown reset

Local mode selector switch with the following positions:

- Local: Engine start and stop can be done only at the local control panel
- Remote: Engine can be started and stopped only remotely
- Blow: In this position it is possible to perform a “blow” (an engine rotation check with indicator valves open and disabled fuel injection) by the start button
- Blocked: Normal start of the engine is not possible

The LCP has back-up indication of the following parameters:

- Engine speed
- Turbocharger speed
- Running hours
- Lubricating oil pressure
- HT cooling water temperature

The local display unit has a set of menus for retrieval and graphical display of operating data, calculated data and event history.

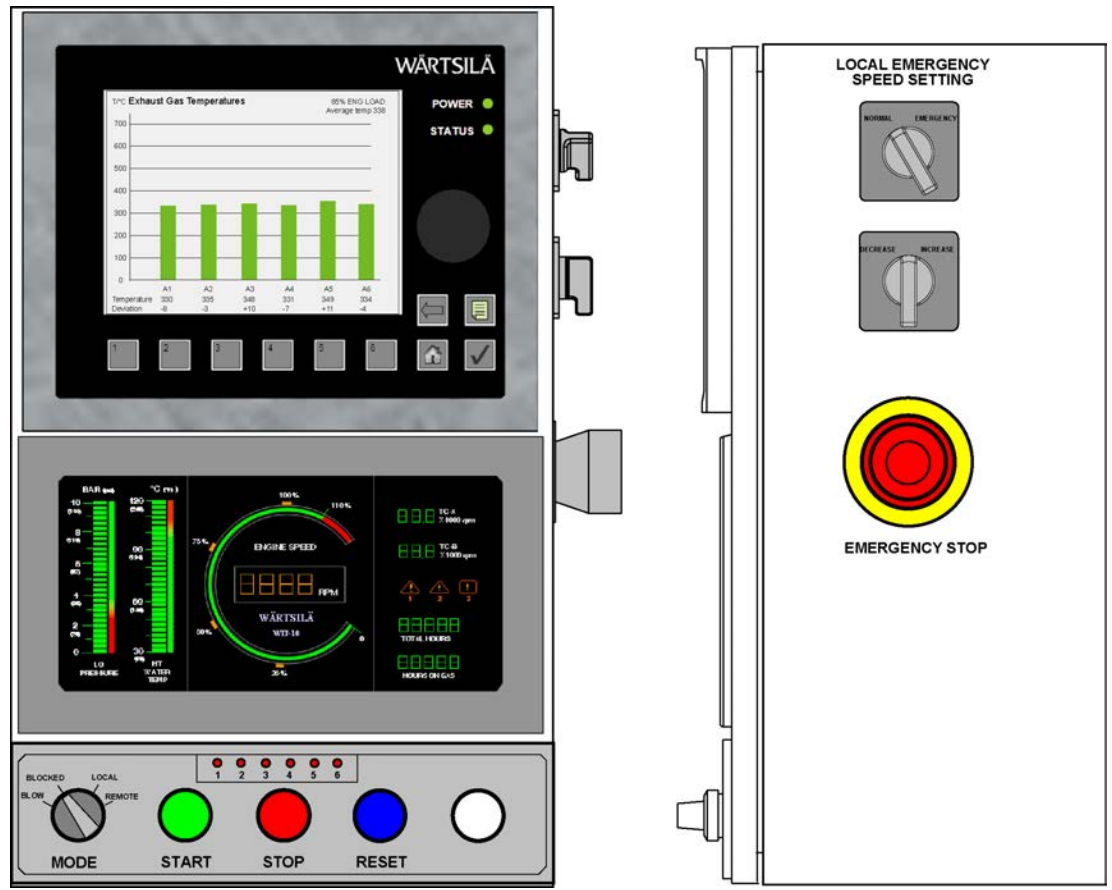

Fig 14-4 Local control panel and local display unit

14.2.2 Engine safety system

The engine safety module handles fundamental safety functions, for example overspeed protection. It is also the interface to the shutdown devices on the engine for all other parts of the control system.

Main features:

- Redundant design for power supply, speed inputs and stop solenoid control
- Fault detection on sensors, solenoids and wires
- Led indication of status and detected faults
- Digital status outputs
- Shutdown latching and reset
- Shutdown pre-warning
- Shutdown override (configuration depending on application)
- Analogue output for engine speed
- Adjustable speed switches

14.2.3 Power unit

A power unit is delivered with each engine. The power unit supplies DC power to the automation system on the engine and provides isolation from other DC systems onboard. The cabinet is designed for bulkhead mounting, protection degree IP44, max. ambient temperature 50°C.

The power unit contains redundant power converters, each converter dimensioned for 100% load. At least one of the two incoming supplies must be connected to a UPS. The power unit supplies the equipment on the engine with 2 x 24 VDC.

Power supply from ship's system:

- Supply 1: 230 VAC / abt. 250 W
- Supply 2: 24 VDC / abt. 250 W

14.2.4 Ethernet communication unit

Ethernet switch and firewall/router are installed in a steel sheet cabinet for bulkhead mounting, protection class IP44.

14.2.5 Cabling and system overview

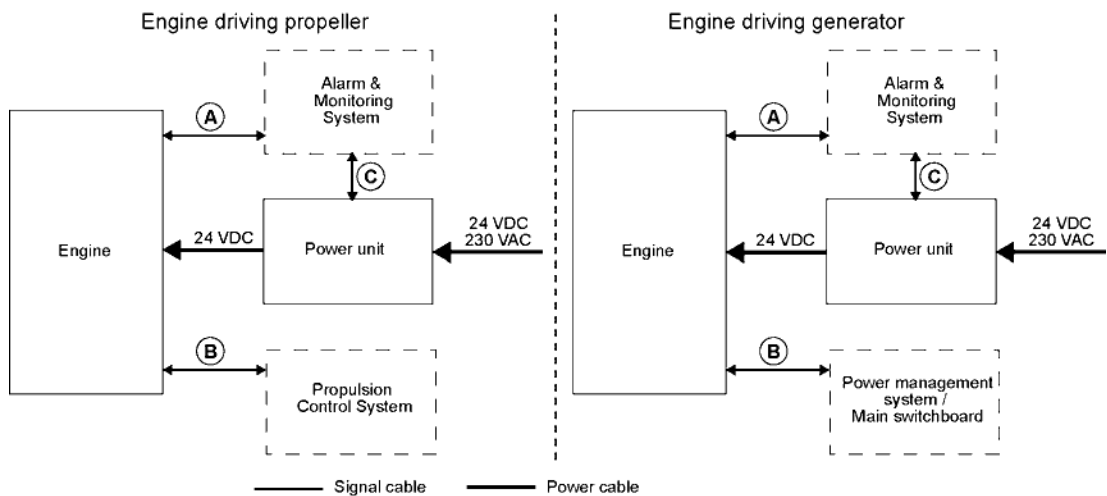

Fig 14-5 UNIC C2 overview

Table 14-4 Typical amount of cables

Cable	From <=> To	Cable types (typical)
A	Engine <=> Power Unit	2 x 2.5 mm ² (power supply) * 2 x 2.5 mm ² (power supply) *
B	Power unit => Communication interface unit	2 x 2.5 mm ² (power supply) *
C	Engine <=> Propulsion Control System Engine <=> Power Management System / Main Switchboard	1 x 2 x 0.75 mm ² 1 x 2 x 0.75 mm ² 1 x 2 x 0.75 mm ² 24 x 0.75 mm ² 24 x 0.75 mm ²
D	Power unit <=> Integrated Automation System	2 x 0.75 mm ²
E	Engine <=> Integrated Automation System	3 x 2 x 0.75 mm ²
F	Engine => Communication interface unit	1 x Ethernet CAT 5
G	Communication interface unit => Integrated automation system	1 x Ethernet CAT 5
H	Gas valve unit => Communication interface unit	1 x Ethernet CAT 5

NOTE



Cable types and grouping of signals in different cables will differ depending on installation.

* Dimension of the power supply cables depends on the cable length.

Power supply requirements are specified in section *Power unit*.

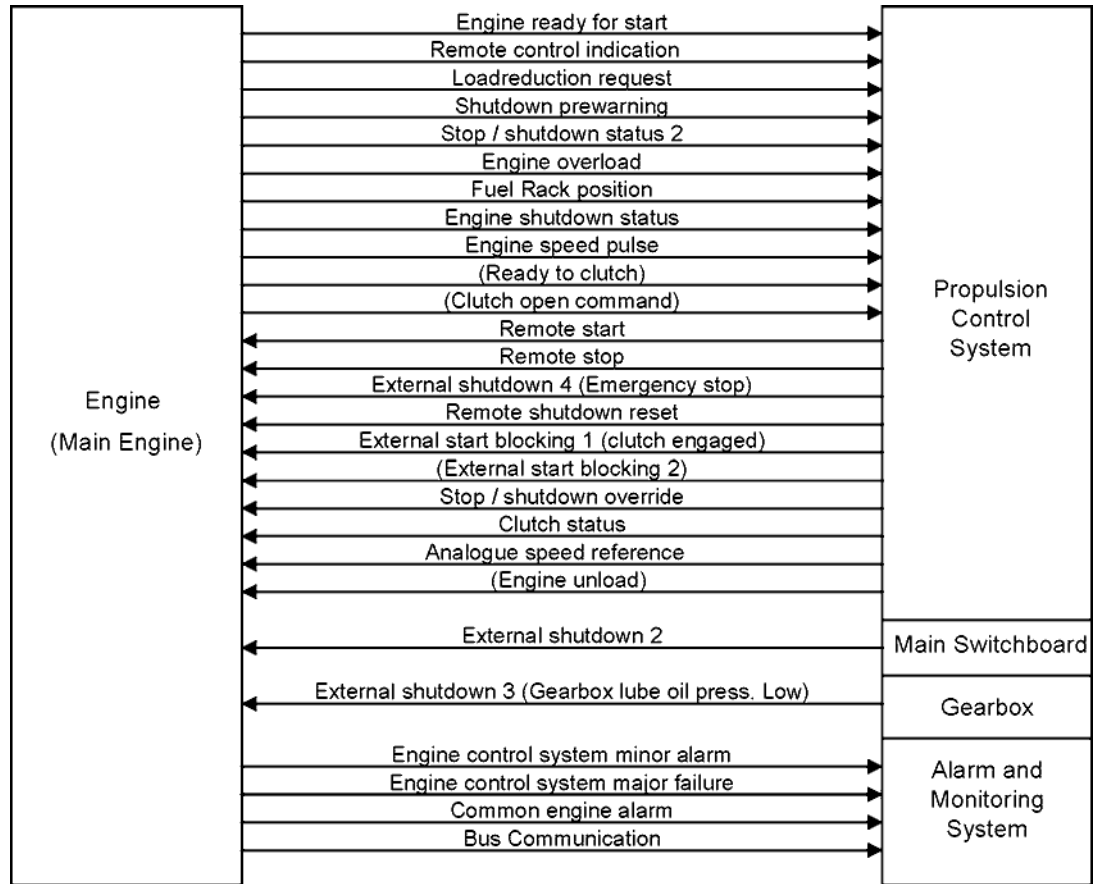

Fig 14-6 Signal overview (Main engine)

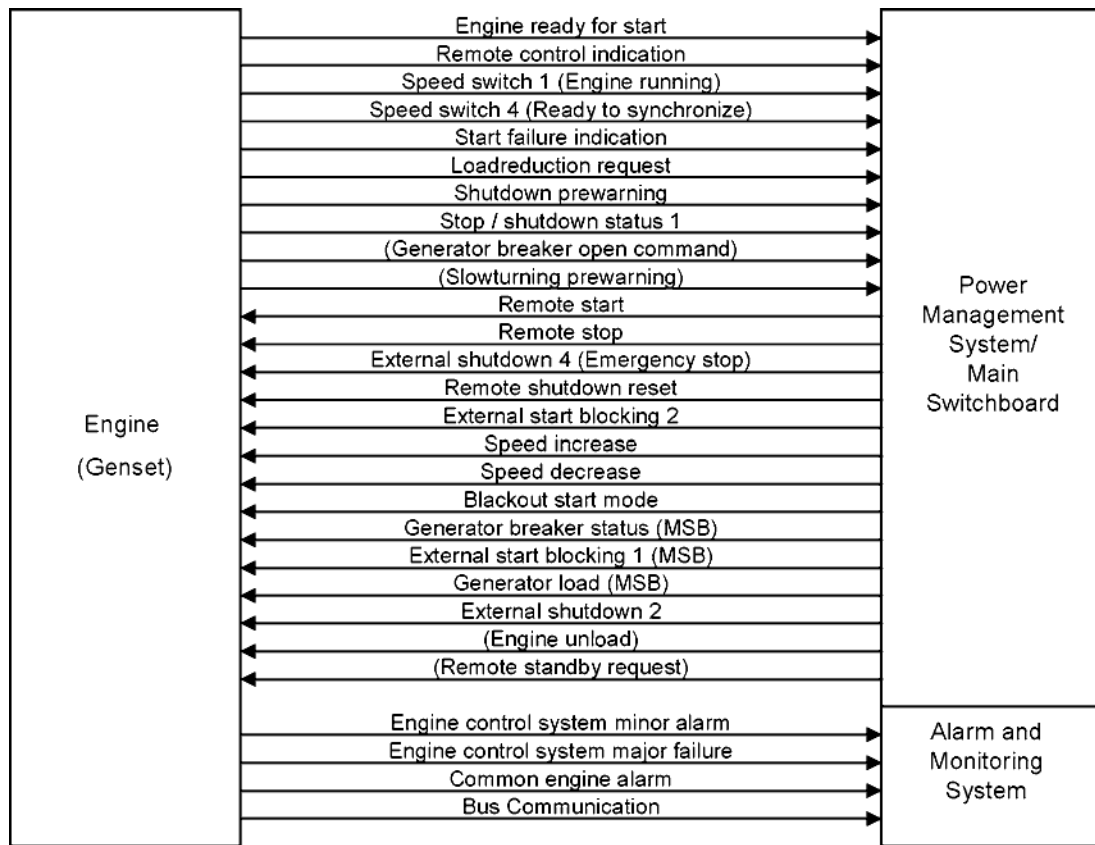

Fig 14-7 Signal overview (Generating set)

14.2.6 Function

14.2.6.1 Start

The engine has a pneumatic starting motor controlled by a solenoid valve. The solenoid valve can be energized either locally with the start button, or from a remote control station. In an emergency situation it is also possible to operate the valve manually.

Starting is blocked both pneumatically and electrically when the turning gear is engaged. Fuel injection is blocked when the stop lever is in stop position (conventional fuel injection).

Startblockings are handled by the system on the engine (main control module).

Startblockings

Starting is inhibited by the following functions:

- Turning gear engaged
- Stop lever in stop position
- Pre-lubricating pressure low
- Local engine selector switch in blocked position
- Stop or shutdown active
- External start blocking 1 (e.g. reduction gear oil pressure)
- External start blocking 2 (e.g. clutch position)
- Engine running

For restarting of a diesel generator in a blackout situation, start blocking due to low pre-lubricating oil pressure can be suppressed for 30 min.

14.2.6.2 Stop and shutdown

Normal stop is initiated either locally with the stop button, or from a remote control station. The control devices on the engine are held in stop position for a preset time until the engine has come to a complete stop. Thereafter the system automatically returns to “ready for start” state, provided that no start block functions are active, i.e. there is no need for manually resetting a normal stop.

Manual emergency shutdown is activated with the local emergency stop button, or with a remote emergency stop located in the engine control room for example.

The engine safety module handles safety shutdowns. Safety shutdowns can be initiated either independently by the safety module, or executed by the safety module upon a shutdown request from some other part of the automation system.

Typical shutdown functions are:

- Lubricating oil pressure low
- Overspeed
- Lubricating oil pressure low in reduction gear

Depending on the application it can be possible for the operator to override a shutdown. It is never possible to override a shutdown due to overspeed or an emergency stop.

Before restart the reason for the shutdown must be thoroughly investigated and rectified.

14.2.6.3 Speed control

Main engines (mechanical propulsion)

The electronic speed control is integrated in the engine automation system.

The remote speed setting from the propulsion control is an analogue 4-20 mA signal. It is also possible to select an operating mode in which the speed reference can be adjusted with increase/decrease signals.

The electronic speed control handles load sharing between parallel engines, fuel limiters, and various other control functions (e.g. ready to open/close clutch, speed filtering). Overload protection and control of the load increase rate must however be included in the propulsion control as described in the chapter "*Operating ranges*".

For single main engines a fuel rack actuator with a mechanical-hydraulic backup governor is specified. Mechanical back-up can also be specified for twin screw vessels with one engine per propeller shaft. Mechanical back-up is not an option in installations with two engines connected to the same reduction gear.

Generating sets

The electronic speed control is integrated in the engine automation system.

The load sharing can be based on traditional speed droop, or handled independently by the speed control units without speed droop. The later load sharing principle is commonly referred to as isochronous load sharing. With isochronous load sharing there is no need for load balancing, frequency adjustment, or generator loading/unloading control in the external control system.

In a speed droop system each individual speed control unit decreases its internal speed reference when it senses increased load on the generator. Decreased network frequency with higher system load causes all generators to take on a proportional share of the increased total load. Engines with the same speed droop and speed reference will share load equally. Loading and unloading of a generator is accomplished by adjusting the speed reference of the individual speed control unit. The speed droop is normally 4%, which means that the difference in frequency between zero load and maximum load is 4%.

In isochronous mode the speed reference remains constant regardless of load level. Both isochronous load sharing and traditional speed droop are standard features in the speed control and either mode can be easily selected. If the ship has several switchboard sections with tie breakers between the different sections, then the status of each tie breaker is required for control of the load sharing in isochronous mode.

14.2.7 Alarm and monitoring signals

Regarding sensors on the engine, please see the internal P&I diagrams in this product guide. The actual configuration of signals and the alarm levels are found in the project specific documentation supplied for all contracted projects.

14.2.8 Electrical consumers

14.2.8.1 Motor starters and operation of electrically driven pumps

Separators, preheaters, compressors and fuel feed units are normally supplied as pre-assembled units with the necessary motor starters included. Various electrically driven pumps require separate motor starters. Motor starters for electrically driven pumps are to be dimensioned according to the selected pump and electric motor.

Motor starters are not part of the control system supplied with the engine, but available as optional delivery items.

Pre-lubricating oil pump

The pre-lubricating oil pump must always be running when the engine is stopped. When engine stops, there is need for TC cooling by post-lubrication. Therefore the pre-lubrication pump shall run at least 90 minutes after an engine stop.

- The lubricating oil pressure should be between 0.6 – 0.7 bar and must be higher than the start blocking pressure
- Engines equipped with an air by-pass valve can, if possible, keep the air by-pass valve open when the engine is stopped to increase the cooling ability

The pump shall start when the engine stops, and stop when the engine starts. The engine control system handles start/stop of the pump automatically via a motor starter.

It is recommended to arrange a back-up power supply from an emergency power source. Diesel generators serving as the main source of electrical power must be able to resume their operation in a black out situation by means of stored energy. Depending on system design and classification regulations, it may be permissible to use the emergency generator.

For dimensioning of the pre-lubricating oil pump starter, the values indicated below can be used. For different voltages, the values may differ slightly.

Table 14-5 Electric motor ratings for pre-lubricating pump

Engine type	Voltage [V]	Frequency [Hz]	Power [kW]	Current [A]
Wärtsilä 20	3 x 400	50	3.0	6.0
	3 x 440	60	3.5	6.2

Stand-by pump, lubricating oil (if installed) (2P04)

The engine control system starts the pump automatically via a motor starter, if the lubricating oil pressure drops below a preset level when the engine is running. There is a dedicated sensor on the engine for this purpose.

The pump must not be running when the engine is stopped, nor may it be used for pre-lubricating purposes. Neither should it be operated in parallel with the main pump, when the main pump is in order.

Stand-by pump, HT cooling water (if installed) (4P03)

The engine control system starts the pump automatically via a motor starter, if the cooling water pressure drops below a preset level when the engine is running. There is a dedicated sensor on the engine for this purpose.

Stand-by pump, LT cooling water (if installed) (4P05)

The engine control system starts the pump automatically via a motor starter, if the cooling water pressure drops below a preset level when the engine is running. There is a dedicated sensor on the engine for this purpose.

Circulating pump for HT preheater (4P04)

The preheater pump shall start when the engine stops (to ensure water circulation through the hot engine) and stop when the engine starts. The engine control system handles start/stop of the pump automatically via a motor starter.

14.3 UNIC 2nd Generation

14.3.1 General Description

14.3.1.1 System Overview

The UNIC automation system is an embedded engine management system. The system has a modular design, and some parts and functions in the UNIC configuration are optional depending on application. The system is specifically designed for the demanding environment on engines, thus special attention has been paid to temperature and vibration endurance. This allows the system to be mounted directly on engine that provides a compact design. The number of inputs and outputs are determined to optimally suit this system arrangement, and the galvanic signal isolation is also made to match these needs.

The UNIC system handles all tasks related to start/stop management, engine safety, fuel management and speed/load control, as well as charge air, cooling, and combustion. The system utilizes modern bus technologies for safe transmission of sensor- and other signals. The UNIC automation system can be accessed with a software-based maintenance tool, which is used for tuning parameters, troubleshooting and for software installation.

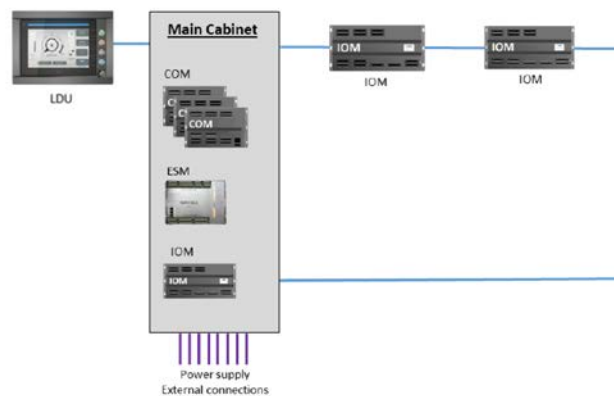

Fig 14-8 UNIC System Overview

14.3.1.2 Main Cabinet

The main cabinet is a main hub of the UNIC control system. All engine external systems are connected via the main cabinet. In addition, all the power supply connections for engine components and actuators are distributed through the main cabinet. The main cabinet holds an Engine Safety Module (ESM) and a number of Communication Modules (COM). Based on engine installation the additional Input / Output Modules (IOM) can be added to main cabinet.

The major parts inside the main cabinet are:

- Communication module, COM** The communication module is the main gateway to the UNIC system, supporting multiple interfaces such as Modbus, OPC, hardwired I/O, etc. COM is a key module for UNIC system communication and responsible for several control functions, software and configuration update management. Depending on engine application the number of COM modules in the main cabinet can vary from 2 to 5 units.

- **Engine Safety module, ESM** The engine safety module handles the most fundamental engine safety functions related to engine over-speed protection, low lube oil pressure and other safety functions required by classification societies. The ESM is able to shutdown the engine without relaying on any other system functions.
- **Input / Output module, IOM** When placed inside the main cabinet the IOM module extends the number of input/output channels in UNIC for the on-engine measurements.

14.3.1.3 Distributed Modules

Around the engine close to inputs and outputs being monitored and / or controlled there are specially designed terminal boxes (WTB) containing UNIC distributed modules. Communication bus HSR allow the distributed modules to communicate with the COM's inside the main cabinet.

- **Input / Output module, IOM** These modules are placed close to inputs and outputs around the engine. When distributed on the engine the main functions of IOM is to measure temperature, pressure and turbo speed. The collected information is then sent to COM for machinery protection evaluation or further distribution to local display and external systems. The IOM module also performs engine some control functions such as exhaust and air waste gate control, VIC solenoid activation.

14.3.1.4 Local Operator Panel

On engines equipped with a jerk-pump system the local control panel is placed close to the stop lever in order to provide support for the operator in case the lever needs to be operated based on information read from the display.

- **Local Display Unit, LDU** A configurable display showing all relevant data collected by UNIC. In addition to the display it contains 4 physical buttons used for various functions. Main use of the buttons are engine start, stop, shutdown reset and local/ remote control selection.
- **Emergency stop push button** An emergency stop push button is always located next to the LDU for stopping the engine quickly in any situation this is seen needed.

14.3.1.5 Software

Platform Software

Wärtsilä Modular Application Platform (WMAP) is the system software in the UNIC control system. The Wärtsilä control applications are implemented on top the WMAP.

The WMAP platform software ensures that safety, control and measurement functions of the system are performed in the strictly defined order.

Control Application

Certain UNIC functionality such as speed and load controller or engine mode control are implemented as control application modules. The control application modules are executed periodically with a defined time interval and in a defined order.

Maintenance and Monitoring Tool

Wärtsilä UNITool is the maintenance and monitoring tool used for engine troubleshooting, monitoring and tuning of the engine parameters. The UNIC software download as well as software configuration is also accomplished with UNITool.

14.3.2 UNIC Hardware

14.3.2.1 Mechanical Design

The UNIC system is designed to meet very high targets on reliability. This includes special measures for redundancy, fault tolerance as well as mechanical and electrical design. The sensors and actuators are designed to be reliable, easy to service and to calibrate. Flying lead design is introduced (wherever possible) to avoid failure prone connectors. Only cables suitable for the demanding engine environment are used on the engines. The well protected point-to-point cables provide the most reliable solution, as they ensure good protection against electrical disturbances, high mechanical strength as well as good protection against chemicals and temperature. Electronic modules which are distributed on the engine, are mounted in specially designed terminal boxes (WTB).

These enclosures are used to facilitate all interconnections on the engine, i.e. they are acting as an interface between the control modules and their peripheral devices.



Fig 14-9 Enclosure for Module Interconnections and Cabling

14.3.2.2 Power Supply

Overview

The required power supply domains are sourced from an off-engine power unit and routed to engine's main cabinet. From there the power supplies are distributed to correct consumers at the engine automation system. Depending on the engine type and functionalities, some of the power supplies may be combined to the same supply.

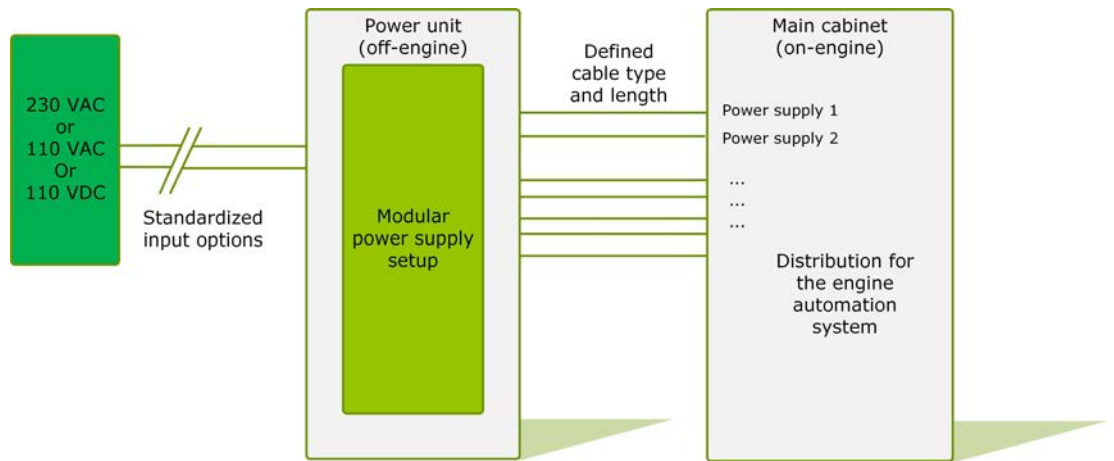

Fig 14-10 Overview of Power Supply Arrangement (One Engine)

Redundancy

UNIC engine automation has input for two supplies per power domain (PSS, PSDx, PSA). The system can operate with one supply per domain in case of failure in the redundant supply. When operating on redundant supplies these are arranged so that single failure can not cause system misbehaviour. In the system consumers, the redundant supplies are combined to one supply in the component design in a way that internal short circuit of the component does not interfere permanently the rest of the power supply system.

DCM is a power supply converter and it is located at the power unit with the circuit breakers

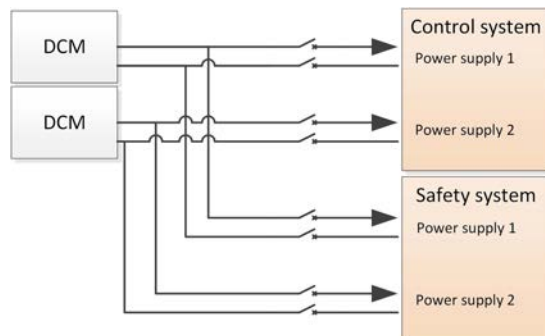

Fig 14-11 Example of the Redundancy and the Division of UNIC Power Supply System

Earth Fault Detection

Each pair of redundant power supply domains has a common earth fault detector in the power unit.

Fuse Selectivity

The UNIC system components are designed to withstand 20ms power cut without rebooting. This is the time window in which the fusing system must react to have at least one of the two redundant supplies recovered after the short circuit situation. The system’s selectivity consists of circuit breakers, fuses and dedicated current limitation. The whole chain is designed so that only the failed branch of the system shuts down in case of short circuit. Rest of the system can continue the operation normally.

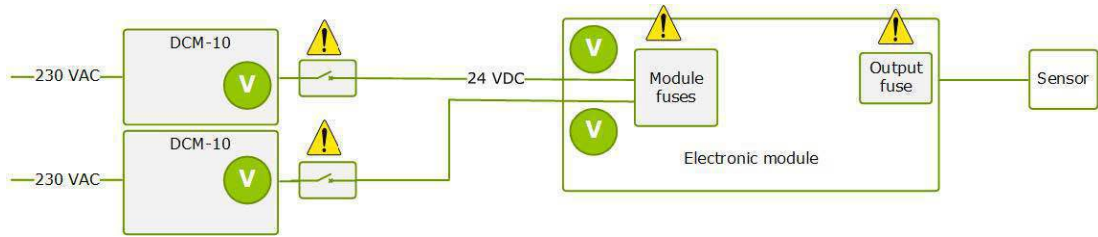

Fig 14-12 Fuse Selectivity Principle of Power Supply System

14.3.2.3 UNIC Modules

Local Display Unit Module

The LDU is an interface to the control and monitoring system of the engine.

Communication Module

The Communication Module (COM) is designed to primarily act as the interface of UNIC.

The module also measures the engine speed and position. External control systems can be connected to UNIC system via the COM module. For control and monitoring purposes it is also possible to connect a number of discrete and/ or analogue signals to the configurable in and output channels.

Input and Output Module

The Input and Output Module (IOM) is used for data acquisition of analogue/ binary/ frequency signals, and also for control, such as waste-gate valve control, by-pass valve control and LT/HT water thermostat valve control.

Power Supply

There are two redundant 24 VDC power supply inputs. Therefore a failure in one power supply will not affect the function of the module.

- Typical operating voltage: 24 VDC
- Operating voltage range: 18-32 VDC
- Protection: overvoltage, under voltage, transients, surge, electronic fuse

Diagnostics: Input current measurement, input voltage measurement

Inputs and Outputs

Input / Output type	Protection / Diagnostics	
Fast Digital Inputs [FDI]	Overcurrent, transient voltages	Frequency mode: 0...25 kHz input range. Digital mode: 0...+32 V input voltage range. 24 V/ 50 mA excitation voltage output
Analog Inputs [AI]	Overcurrent, transient voltages,unintentional connection to 32 V, wire break detection, short circuit detection	mA-mode range: 4...25 mA, 24 V/ 40 mA excitation voltage output
Analog Digital Input Output [ADIO]	Overcurrent, transient voltages,unintentional connection to 32 V. Wire break detection, short circuit detection (non in TC mode)	mA mode range: 0..24 mA, TC-mode range (K-type): -50...800 °C, PT1000n range: -60...200 °C, PT1000w range: 0...800 °C, PT100 range: -60...200 °C, Digital output mode, Digital input mode, 24 V/ 50 mA excitation voltage output
Identification Inputs [ID]	N/A	Module identification within the system. Active when connected to REF(0V).
High Side Drive [HSD]	Overcurrent, transient voltages. Wire break and short circuit detection	Current output range: 0...1500 mA, Current set-point mode, PWM control mode, ON/OFF mode with digital output and DC supply
Analog Output [AO]	Overcurrent, transient voltages, unintentional connection to 32 V. Wire break detection.	Isolated interface, mA mode range: 2..22mA

Fig 14-13 IOM module I/O types

High Availability Seamless Redundancy network

High Availability Seamless Redundancy (HSR) network interface is used for communication between UNIC modules which support HSR protocol.

Controller Area Network

Controller area network (CAN) interface can be used for communication with other CAN enabled devices.

LED Indication

LED indication	Description
Static green	Start delay
Flashing green	Starting up
Fading green	Operational (normal state)
Static yellow	Software running, but an internal module failure detected
Flashing yellow	Power supply failure, try rebooting the module
Flashing red	Major internal failure detected
Static blue	New module with no system software
Fading blue	Programming ongoing
Static white	The software not functioning correctly
Off	Module not powered or software not running

Fig 14-14 Status LED

Run Mode

A run mode can only be entered from a start mode if no stop, shutdown or emergency stop requests are active. The transition from start to run mode happens when an engine rotational speed is above a pre-set run mode speed limit.

Shutdown Mode

A shutdown mode can be entered from a stop mode, stand-by mode, start mode or a run mode.

Emergency Stop Mode

Emergency stop mode has the highest priority and can be entered from any other mode.

14.3.3.2 Engine Speed Measurement

Speed sensors mounted close to the flywheel measure the engine speed. The engine speed is used for the internal speed and load controller, engine speed-dependent control maps and over-speed protection. Two speed sensors installed on separate modules for full mechanical separation and redundancy. Any speed sensor failure or a COM module failure moves the engine speed calculation to the other COM module without affecting engine performance.

14.3.3.3 Speed/ Load Controller

The UNIC speed/load control sets the engine fuel demand.

The speed or load reference is calculated and used in the closed-loop speed/load controller to set the engine fuel demand.

Synchronizing/ Clutch-in

Synchronization/clutching in is needed before transferring from CB open mode to the other control modes.

Load Sharing

Load sharing is done to divide the load between the engines.

Speed/ Load Modes

The UNIC speed/load controller has four different speed load control modes.

CB open control

CB open control is active during engine start, and in run mode until the generator breaker or the clutch has been closed. Start fuel limiter is used in this mode. Binary/ analogue inputs are enabled for synchronisation purpose. The PID parameters are engine speed dependent.

Speed droop control and load sharing

Speed droop control and load sharing become active after the closure of the generator breaker or the clutch. Load sharing is based on a built-in droop curve, which means that the internal engine speed reference will decrease proportionally to the load increase. After a major load increase, the internal speed reference may need to be increased by the power management system (PMS) to ensure that the bus frequency is kept within a certain window regardless of the net load level. Control of the speed reference from a plant management system is necessary. The PID parameters are dependent on the engine speed and load.

Isochronous control and load sharing

Isochronous control and load sharing become active after closure of the generator breaker or the clutch when isochronous load sharing has been selected. In this control mode the load sharing is provided over load sharing CAN. The engine speed remains unaffected by a droop slope at all load levels without speed reference adjustments from a plant management system. The PID parameters are dependent on the engine speed and load.

True kW control

True kW control becomes active after the closure of the generator breaker when kW control has been selected. The mode is used normally for operation in parallel with the grid, but it can also be used in island mode, for a limited number of engines. Engine speed is used only to ensure that the speed range is within defined engine safety- and BMEP limits. The PID parameters are engine load dependent.

Fuel Demand Limiters

The fuel demand set by the speed/load controller can be limited using fuel demand limiters.

The following demand limiters are available:

- A start fuel limiter is used during engine start, and a clutch-in limiter when clutching in a single main engine application or the first engine of a tandem main engine application.
- The fuel demand can also be limited using engine load, engine speed or charge air pressure dependent limiters.

If several limiters are active simultaneously, the maximum fuel demand level is determined according to the lowest limiter value.

14.3.3.4 Air and Exhaust

Variable Inlet Valve Control

Variable Inlet valve Closing (VIC) controls the closing of the inlet valves.

The inlet valve closing can be delayed to reduce which improves low load running, emergency loading and transient operation. At medium and higher load the camshaft profile (increased timing) can be utilized to reduce the compression temperature which results in reduced NOx emissions and reduce the specific fuel-oil consumption (SFOC).

The VIC valve is activated based on engine load and speed. In addition, during positive load transients and active emergency loading rate situations, the VIC is also activated. For engine safety reasons the VIC is disabled if the charge air pressure is above a preset limit regardless of the state of the other activation components.

Waste-gate Valve Control

UNIC controls one or more waste-gate valves to regulate the amount of air fed into the engine by controlling the charge air pressure.

Charge air pressure control

The charge air pressure control is a closed loop control with an engine speed and load based charge air pressure set-point. The engine is fitted with charge air pressure sensor(s) which is used as feedback to the control. The waste-gate control limits the charge air pressure on higher engine loads.

Exhaust gas temperature control

The exhaust gas temperature control is used regulate the exhaust gas temperature to a load based set-point temperature to ensure optimal exhaust treatment done by the selective catalytic reduction (SCR) system. The exhaust gas temperature control is available as an additional control method for the waste-gate control. It is activated/ deactivated with an external input to the UNIC system.

14.3.3.5 Fuel Rack Actuator Control

The amount of fuel to be injected by each injector is set by a mechanical linkage called the fuel rack. UNIC controls the fuel rack position via analogue output. The position of the fuel rack is controlled based on the calculated fuel demand required to maintain the desired engine speed or load.

14.3.4 UNIC Machinery Protection

Most sensors connected to UNIC have some machinery protection specified. Depending on how critical an abnormal measurement is for the engine, different levels of protective actions are configured. UNIC machinery protection is divided in the following classes:

- Alarm
- Start Blocking
- Load Reduction Request
- Shutdown
- Emergency Stop

14.3.4.1 Alarm

When a monitored engine signal exceeds its pre-defined set-point, an alarm is activated. The alarm is presented in the external alarm system and in the local display. All alarms trigger the "common alarm" signal, which toggles off and on again each time a new alarm triggers it.

Sensor / signal failure alarm (SF)

All analogue input and output signals have pre-set min and max limits defined for the electrical signal. In case either of these are exceeded the signal is set to sensor / signal failure status. When a signal is set to SF status, it is no longer used by machinery protection.

Set point alarm (SP)

A set point alarm is activated when input signal value or internally calculated values (such as temperature or pressure deviation) exceeds a configured value i.e. set point.

14.3.4.2 Start Blocking

Engine starting is blocked when a start block is active. Start blocking signals are connected to the COM module or to an IOM module. It is not allowed to by-pass a start blocking since it may cause a serious hazard either for the engine and its surrounding or for associated systems.

14.3.4.3 Load Reduction Request

Load reduction request is an automatic safety measure initiated by UNIC, used to reduce the maximum load output of the engine under certain abnormal engine conditions. Whenever there is an abnormal situation on the engine or the generator, which endangers a secure or proper operation of the engine, a SP (Set Point) load reduction or SF (Sensor Failure) load reduction can be activated. The maximum available load output can be different depending of the type of abnormality. UNIC interacts with the external plant management system, particularly in case of speed droop control mode.

14.3.4.4 Shutdown and Emergency Stop

An engine shutdown or an emergency stop can be initiated by UNIC or by a protective safety system. Wärtsilä has an internal standard that defines engine shutdowns, unavoidable shutdowns and emergency stops which are anaged by the UNIC control system.

14.3.5 Protective Safety System

The main tasks of protective system on engine:

- Engine Shutdown in Case of an Overspeed Situation
- Engine Shutdown in Case of Too Low Lubricating Oil Pressure
- Engine Shutdown in Case of Too High HT Cooling Water Temperature

- Fault Detection on Sensors, Solenoid and Wires

14.3.5.1 Shutdown and Emergency Stop

The protective safety system showdowns are always communicated to UNIC, however protective system is cable of engine shutdown even if the UNIC system is not operational or communication between the two systems is broken. Critical sensors are connected to the Engine Safety Module (ESM), and their measurements can activate automatic shutdowns. All shutdowns initiated by ESM are communicated to UNIC via CANOpen communication bus. The shutdowns are latching and require a reset before the engine can be restarted.

As a minimum, the engine is equipped with the following sensors/signals that can cause an automatic shutdown or emergency stop:

- Emergency Stop Button
- Low Lubrication Oil Pressure, Engine Inlet
- Engine Speed (Overspeed Trip)

Emergency Stop Button

Pressing the local or (engine) external emergency stop button shuts down the engine instantly. Both the external emergency stop signal and the local HS723 emergency stop button activate "OS7305 External shutdown 4".

Low Lubricating Oil Pressure Shutdown

A dedicated safety pressure transmitter "PTZ201 LO press, engine inlet" is connected to the engine safety module (ESM). It activates the engine shutdown if the lubricating oil pressure is too low. If a transmitter failure is detected, the shutdown is blocked and a sensor failure is indicated.

High HT Water Temperature Shutdown

Dedicated safety sensors TEZ402 and TEZ403 (for V-engines) are connected to the ESM for the activation of shutdown in case of high HT water temperature. For V-engines, the ESM always uses the higher of the values received from the two sensors. If a sensor failure is detected, the shutdown is blocked and a sensor failure indicated.

Engine Overspeed Shutdown

The engine speed is measured with two independent speed sensors ST173 and ST174 that are connected to ESM module. The measured values are used to trig the internal overspeed trip circuits. The triggering point for the overspeed shutdown is set to 115% of the nominal engine speed.

15. Foundation

Engines can be either rigidly mounted on chocks, or resiliently mounted on rubber elements. If resilient mounting is considered, Wärtsilä must be informed about existing excitations such as propeller blade passing frequency. Dynamic forces caused by the engine are listed in the chapter *Vibration and noise*.

15.1 Steel structure design

The system oil tank may not extend under the reduction gear, if the engine is of dry sump type and the oil tank is located beneath the engine foundation. Neither should the tank extend under the support bearing, in case there is a PTO arrangement in the free end. The oil tank must also be symmetrically located in transverse direction under the engine.

The foundation and the double bottom should be as stiff as possible in all directions to absorb the dynamic forces caused by the engine, reduction gear and thrust bearing. The foundation should be dimensioned and designed so that harmful deformations are avoided.

The foundation of the driven equipment must be integrated with the engine foundation.

15.2 Mounting of main engines

15.2.1 Rigid mounting

Main engines can be rigidly mounted to the foundation either on steel chocks or resin chocks.

Prior to installation the shipyard must send detailed plans and calculations of the chocking arrangement to the classification society and to Wärtsilä for approval.

The engine has four feet integrated to the engine block. There are two Ø22 mm holes for M20 holding down bolts and a threaded M16 hole for a jacking screw in each foot. The Ø22 holes in the seating top plate for the holding down bolts can be drilled through the holes in the engine feet. In order to avoid bending stress in the bolts and to ensure proper fastening, the contact face underneath the seating top plate should be counterbored.

Holding down bolts are through-bolts with lock nuts. Selflocking nuts are acceptable, but hot dip galvanized bolts should not be used together with selflocking (nyloc) nuts. Two of the holding down bolts are fitted bolts and the rest are clearance (fixing) bolts. The fixing bolts are M20 8.8 bolts according DIN 931, or equivalent. The two Ø23 H7/m6 fitted bolts are located closest to the flywheel, one on each side of the engine. The fitted bolts must be designed and installed so that a sufficient guiding length in the seating top plate is achieved, if necessary by installing a distance sleeve between the seating top plate and the lower nut. The guiding length in the seating top plate should be at least equal to the bolt diameter. The fitted bolts should be made from a high strength steel, e.g. 42CrMo4 or similar and the bolt should have a reduced shank diameter above the guiding part in order to ensure a proper elongation. The recommended shank diameter for the fitted bolts is 17 mm.

The tensile stress in the bolts is allowed to be max. 80% of the material yield strength and the equivalent stress during tightening should not exceed 90% of the yield strength.

Lateral supports must be installed for all engines. One pair of supports should be located at the free end and one pair (at least) near the middle of the engine. The lateral supports are to be welded to the seating top plate before fitting the chocks. The wedges in the supports are to be installed without clearance, when the engine has reached normal operating temperature. The wedges are then to be secured in position with welds. An acceptable contact surface must be obtained on the wedges of the supports.

15.2.1.1 Resin chocks

The recommended dimensions of resin chocks are 150 x 400 mm. The total surface pressure on the resin must not exceed the maximum value, which is determined by the type of resin and the requirements of the classification society. It is recommended to select a resin that has a type approval from the relevant classification society for a total surface pressure of 5 N/mm². (A typical conservative value is p_{tot} 3.5 N/mm²).

During normal conditions, the support face of the engine feet has a maximum temperature of about 75°C, which should be considered when selecting the type of resin.

The bolts must be made as tensile bolts with a reduced shank diameter to ensure sufficient elongation since the bolt force is limited by the permissible surface pressure on the resin. For a given bolt diameter the permissible bolt tension is limited either by the strength of the bolt material (max. stress 80% of the yield strength), or by the maximum permissible surface pressure on the resin.

15.2.1.2 Steel chocks

The top plates of the foundation girders are to be inclined outwards with regard to the centre line of the engine. The inclination of the supporting surface should be 1/100 and it should be machined so that a contact surface of at least 75% is obtained against the chocks.

Recommended size of the chocks are 115 x 170 mm at the position of the fitted bolts (2 pieces) and 115 x 190 mm at the position of the fixing bolts (6 pieces). The design should be such that the chocks can be removed, when the lateral supports are welded to the foundation and the engine is supported by the jacking screws. The chocks should have an inclination of 1:100 (inwards with regard to the engine centre line). The cut out in the chocks for the fixing bolts shall be 24...26 mm (M20 bolts), while the hole in the chocks for the fitted bolts shall be drilled and reamed to the correct size (\varnothing 23 H7) when the engine is finally aligned to the reduction gear.

The design of the holding down bolts is shown in figure [Chocking of main engines \(V69A0238C\)](#). The bolts are designed as tensile bolts with a reduced shank diameter to achieve a large elongation, which improves the safety against loosening of the nuts.

15.2.1.3 Steel chocks with adjustable height

As an alternative to resin chocks or conventional steel chocks it is also permitted to install the engine on adjustable steel chocks. The chock height is adjustable between 30...50 mm for the approved type of chock. There must be a chock of adequate size at the position of each holding down bolt.

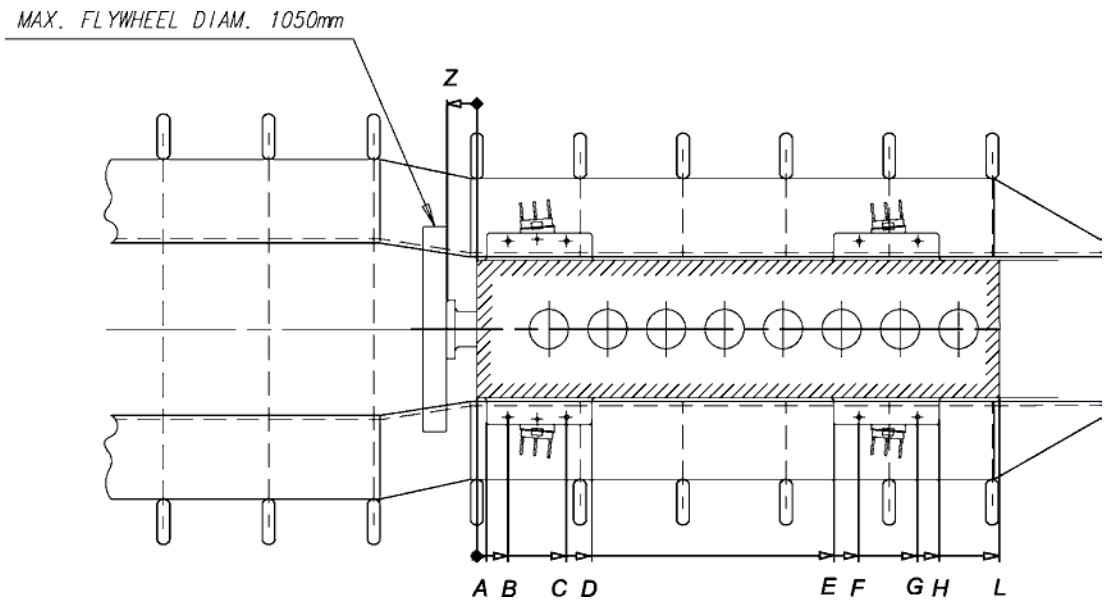

Fig 15-1 Main engine seating, view from above (DAAE017514a)

Engine	Dimensions [mm]									
	A	B	C	D	E	F	G	H	L	Z
W 4L20	50	160	460	590	930	1060	1360	1470	1480	155
W 6L20	50	160	460	590	1530	1660	1960	2070	2080	155
W 8L20	50	160	460	590	1830	1960	2260	2370	2680	155
W 9L20	50	160	460	590	2130	2260	2560	2670	2980	155

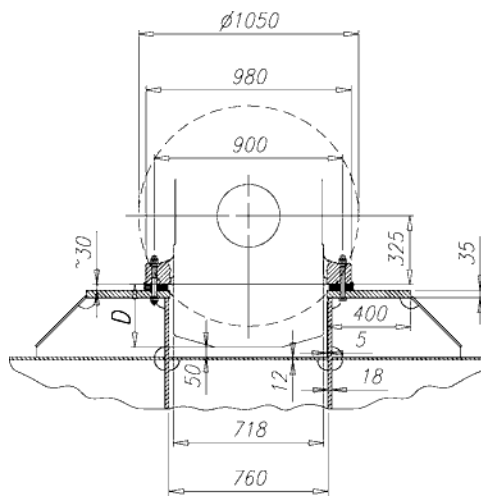

Fig 15-2 Main engine seating, end view (DAAE017514a)

Engine type	(D) Deep sump [mm]	(D) Wet sump [mm]	(D) Dry sump [mm]
4L	-	400	-
6L	500	300	300
8L	500	300	300
9L	500	300	300

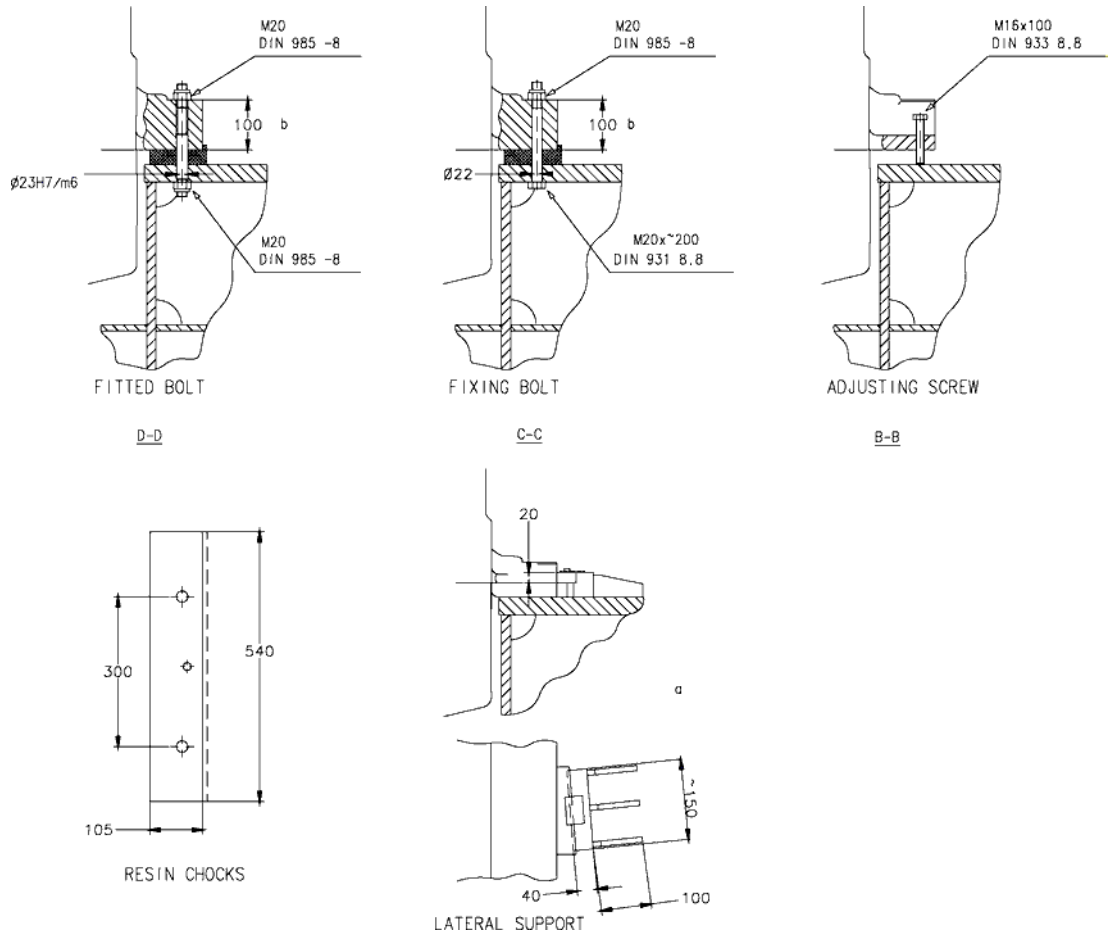

Fig 15-3 Chocking of main engines (V69A0238C)

15.2.2 Resilient mounting

In order to reduce vibrations and structure borne noise, main engines can be resiliently mounted on rubber mounts. The transmission of forces emitted by a resiliently mounted engine is 10-20% compared to a rigidly mounted engine.

For resiliently mounted engines a speed range of 750-1000 rpm is generally available.

Conical rubber mounts are used in the normal mounting arrangement and additional buffers are thus not required. A different mounting arrangement can be required for wider speed ranges (e.g. FPP installations).

Resilient mounting is not available for W 4L20 engines.

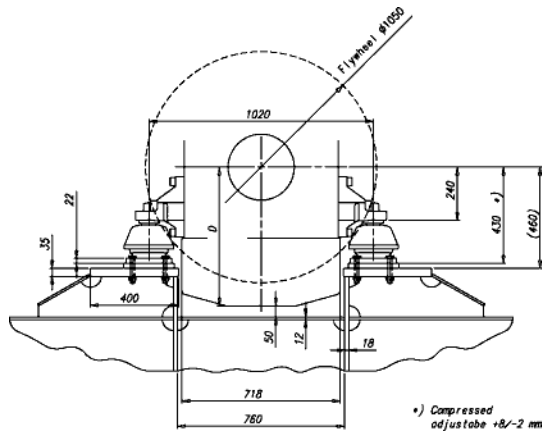

Engine type	(D) Deep sump [mm]	(D) Wet sump [mm]	(D) Dry sump [mm]
6L	825	625	625
8L	825	625	625
9L	825	625	625

Fig 15-4 Resilient mounting (DAAE003263A)

15.3 Mounting of generating sets

15.3.1 Generator feet design

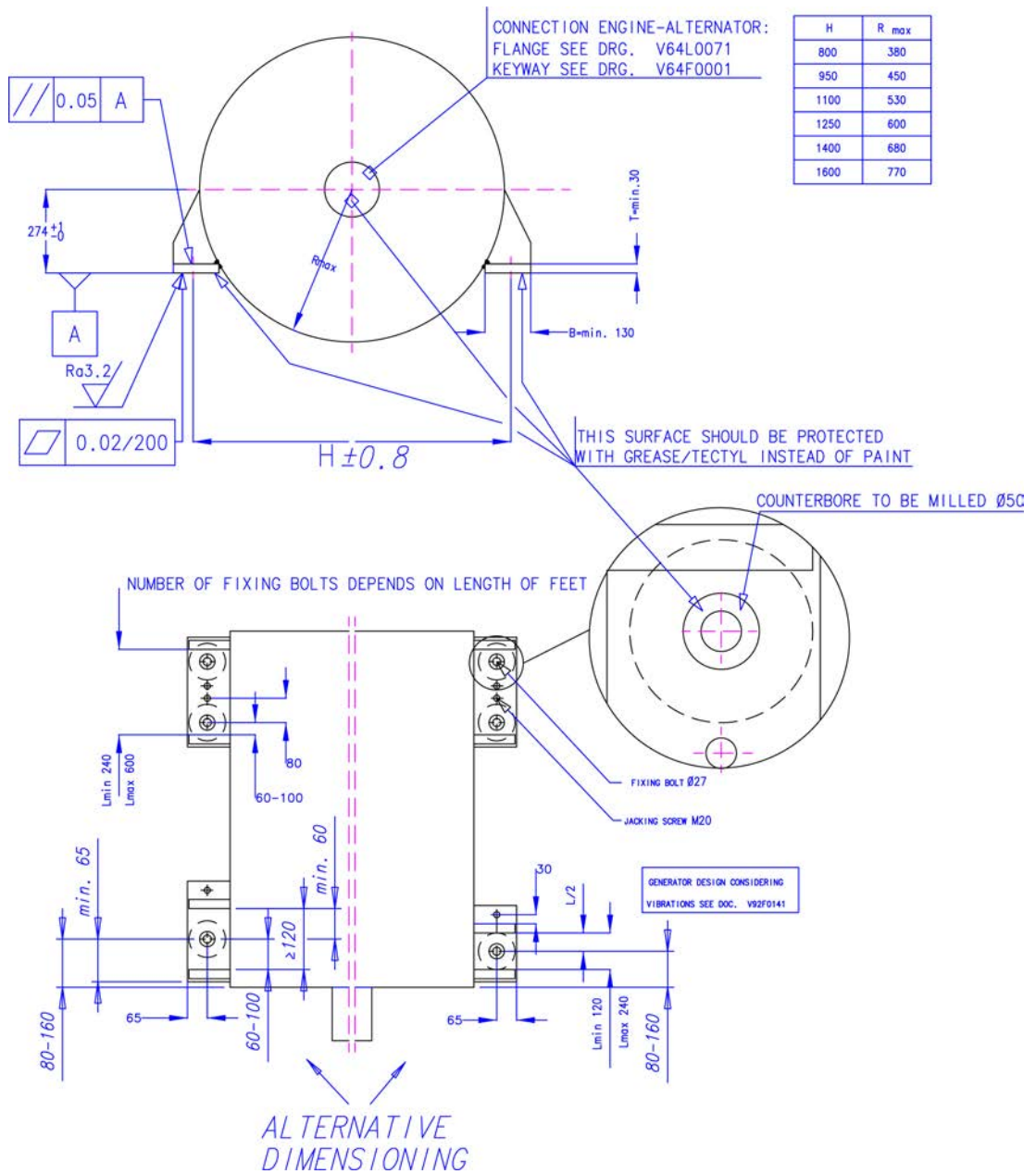

Fig 15-5 Instructions for designing the feet of the generator and the distance between its holding down bolt (V92F0134E)

15.3.2 Resilient mounting

Generating sets, comprising engine and generator mounted on a common base frame, are usually installed on resilient mounts on the foundation in the ship.

The resilient mounts reduce the structure borne noise transmitted to the ship and also serve to protect the generating set bearings from possible fretting caused by hull vibration.

The number of mounts and their location is calculated to avoid resonance with excitations from the generating set engine, the main engine and the propeller.

NOTE

i To avoid induced oscillation of the generating set, the following data must be sent by the shipyard to Wärtsilä at the design stage:

- main engine speed [rpm] and number of cylinders
- propeller shaft speed [rpm] and number of propeller blades

The selected number of mounts and their final position is shown in the generating set drawing.

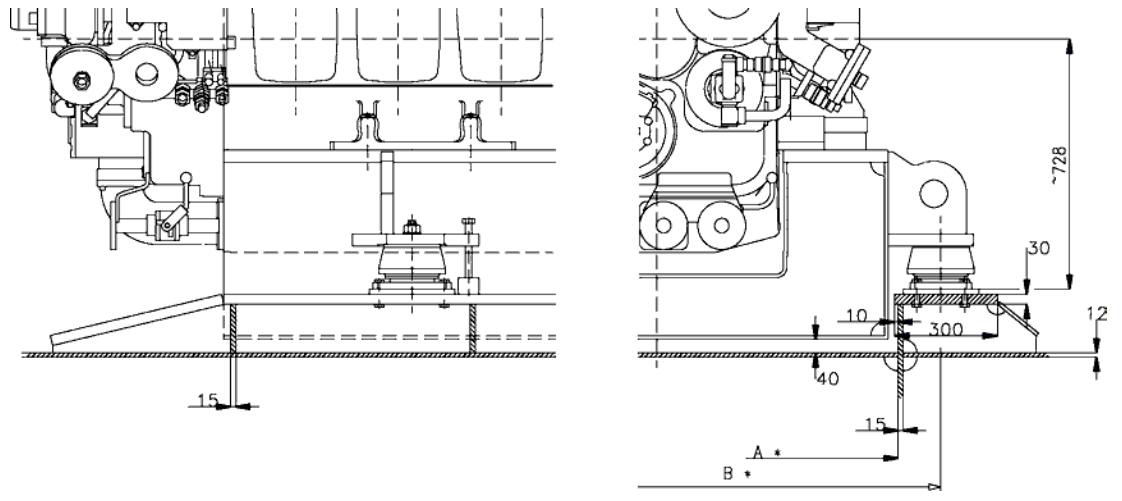

Fig 15-6 Recommended design of the generating set seating (V46L0720G)

Engine type	A*	B*
4L	1330 / 1480	1580 / 1730
6L	1330 / 1480 / 1630	1580 / 1730 / 1880
8L	1480 / 1630	1730 / 1880
9L	1480 / 1630 / 1860	1730 / 1880 / 2110

* *Dependent on generator width*

15.3.3 Rubber mounts

The generating set is mounted on conical resilient mounts, which are designed to withstand both compression and shear loads. In addition the mounts are equipped with an internal buffer to limit movements of the generating set due to ship motions. Hence, no additional side or end buffers are required.

The rubber in the mounts is natural rubber and it must therefore be protected from oil, oily water and fuel.

The mounts should be evenly loaded, when the generating set is resting on the mounts. The maximum permissible variation in compression between mounts is 2.0 mm. If necessary, chocks or shims should be used to compensate for local tolerances. Only one shim is permitted under each mount.

The transmission of forces emitted by the engine is 10-20% when using conical mounts.

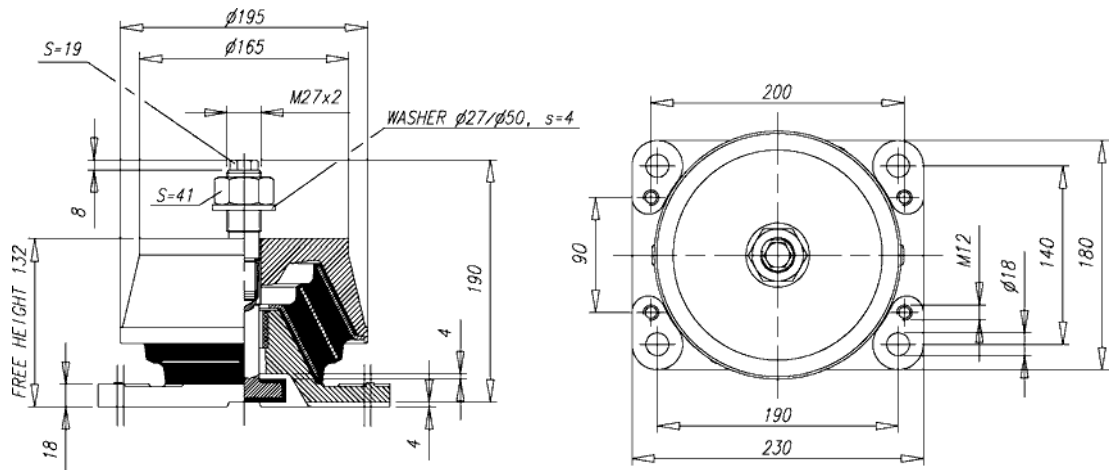

Fig 15-7 Rubber mounts (V46L0706C)

15.4 Flexible pipe connections

When the engine or the generating set is resiliently installed, all connections must be flexible and no grating nor ladders may be fixed to the generating set. When installing the flexible pipe connections, unnecessary bending or stretching should be avoided. The external pipe must be precisely aligned to the fitting or flange on the engine. It is very important that the pipe clamps for the pipe outside the flexible connection must be very rigid and welded to the steel structure of the foundation to prevent vibrations, which could damage the flexible connection.

16. Vibration and Noise

Generating sets comply with vibration levels according to ISO 8528-9. Main engines comply with vibration levels according to ISO 10816-6 Class 5.

16.1 External forces & couples

Some cylinder configurations produce external forces and couples. These are listed in the tables below.

The ship designer should avoid natural frequencies of decks, bulkheads and superstructures close to the excitation frequencies. The double bottom should be stiff enough to avoid resonances especially with the rolling frequencies.

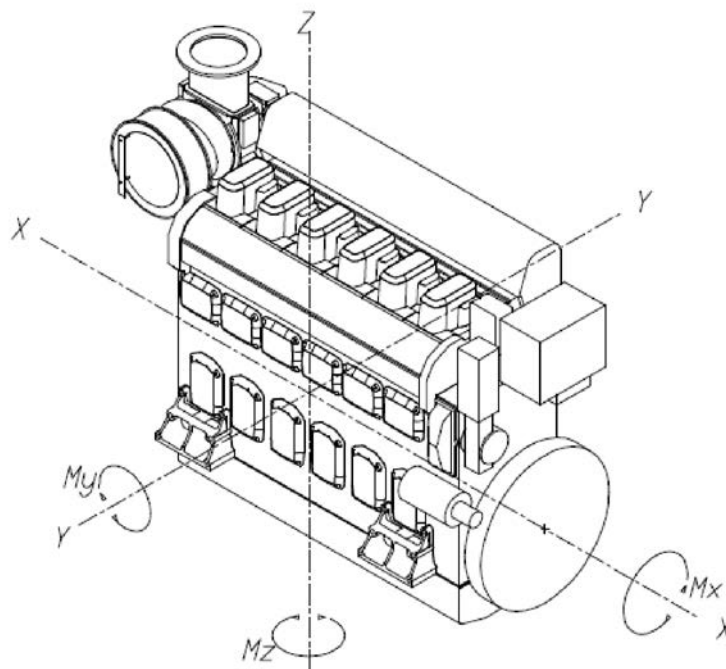

Fig 16-1 External forces & couples

External forces

$F_z = 0, F_y = 0$ for all others than 4 and 8 cylinder engines.

Table 16-1 External forces

Engine	Speed [RPM]	Freq. [Hz]	F_y [kN]	Freq. [Hz]	F_z [kN]
4L20	900	30	--	30	--
		60	--	60	1
		--	--	--	--
	1000	33.3	--	33.3	--
		67	--	67	1
		--	--	--	--

Engine	Speed [RPM]	Freq. [Hz]	F _y [kN]	Freq. [Hz]	F _z [kN]
8L20	900	60	--	60	2
		--	--	--	--
		--	--	--	--
	1000	67	--	67	3
		--	--	--	--
		--	--	--	--
	1200	80	--	80	4
		--	--	--	--
		--	--	--	--

-- couples and forces = zero or insignificant.

External couples

$M_z = 0$, $M_y = 0$ for all others than 9 cylinder engines.

Table 16-2 External couples

Engine	Speed [RPM]	Freq. [Hz]	M_y [kNm]	Freq. [Hz]	M_z [kNm]
9L20	720	12	4.4	12	4.4
		24	3	--	--
		48	0.3	--	--
	750	12.5	4.7	12.5	4.7
		25	3.3	--	--
		50	0.3	--	--
	900	15	7.0	15	7.0
		30	4.8	--	--
		60	0.4	--	--
	1000	17	8	17	8
		33	6	33	--
		67	1	67	--
	1200	20	12	20	12
		40	8	40	--
		80	1	80	--

-- couples and forces = zero or insignificant.

Table 16-3 Torque variations at 100% load

Engine	Speed [RPM]	Freq. [Hz]	M _X [kNm]	Freq. [Hz]	M _X [kNm]	Freq. [Hz]	M _X [kNm]
4L20	900	30	9.9	60	9.8	90	3.5
	1000	33.3	6.6	67	9.6	100	3.5
6L20	900	45	15.4	90	5.2	135	0.4
	1000	50	10	100	5	150	1
	1200	60	6	120	5	180	1
8L20	900	60	19.6	120	1.5	180	0.5
	1000	67	17	133	2	--	--
	1200	80	16	160	2	--	--
9L20	900	67.5	17.8	135	0.6	203	0.4
	1000	75	16	150	1	--	--
	1200	90	16	180	1	--	--

-- couples and forces = zero or insignificant.

900 rpm, 185 kW/cyl

1000 rpm, 200 kW/cyl

1200 rpm, 220 kW/cyl

Table 16-4 Torque variations at 0% load

Engine	Speed [RPM]	Freq. [Hz]	M _X [kNm]	Freq. [Hz]	M _X [kNm]	Freq. [Hz]	M _X [kNm]
4L20	720	24	4.8	48	1.6	72	0.8
	750	25	5.6	50	1.5	75	0.8
	900	30	10	60	1.4	90	0.9
	1000	33.3	13	66.7	1.3	100	0.9
6L20	720	36	1.4	72	1.2	108	0.3
	750	37.5	1.9	75	1.2	112.5	0.3
	900	45	4.7	90	1.3	135	0.4
	1000	50	6	100	1	150	--
	1200	60	11	120	1	180	--
8L20	720	48	3.1	96	0.7	--	--
	750	50	3.1	100	0.7	--	--
	900	60	2.8	120	0.7	--	--
	1000	67	3	133	1	--	--
	1200	80	2	160	1	--	--
9L20	720	54	3.5	108	0.5	--	--
	750	56.3	3.5	112.5	0.5	--	--
	900	67.5	3.6	135	0.5	--	--
	1000	75	4	150	1	--	--
	1200	90	4	180	1	--	--

-- couples and forces = zero or insignificant.

16.2 Mass moments of inertia

The mass-moments of inertia of the propulsion engines (including flywheel, coupling outer part and damper) are typically as follows:

Engine	J [kgm ²]
W 4L20	90...120
W 6L20	90...150
W 8L20	110...160
W 9L20	100...170

16.3 Structure borne noise

Typical structure borne noise levels above and below the resilient mounts are presented as vibration velocity in dB, reference 1x10⁻⁶ mm/s, per octave band.

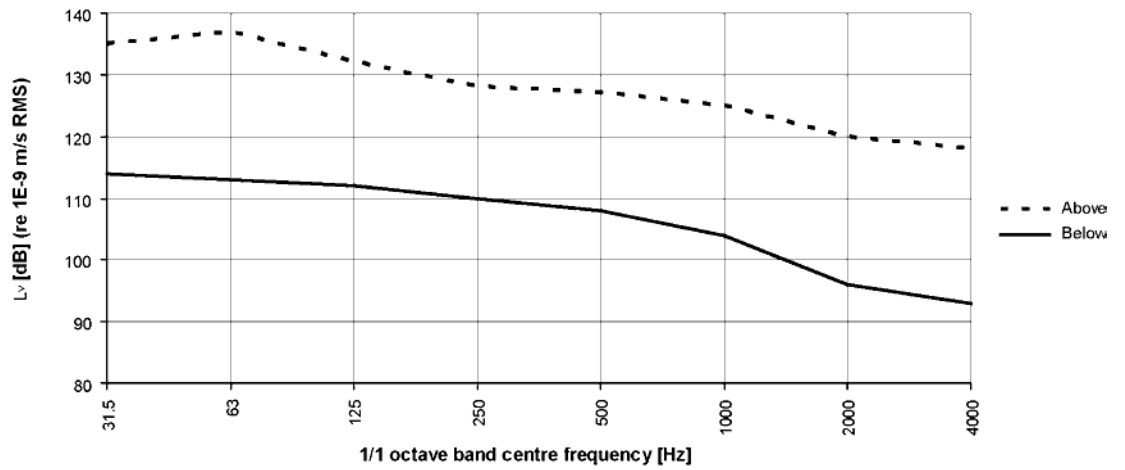

Fig 16-2 Main engines, typical structure borne noise levels above and below resilient mounts (DAAB814306)

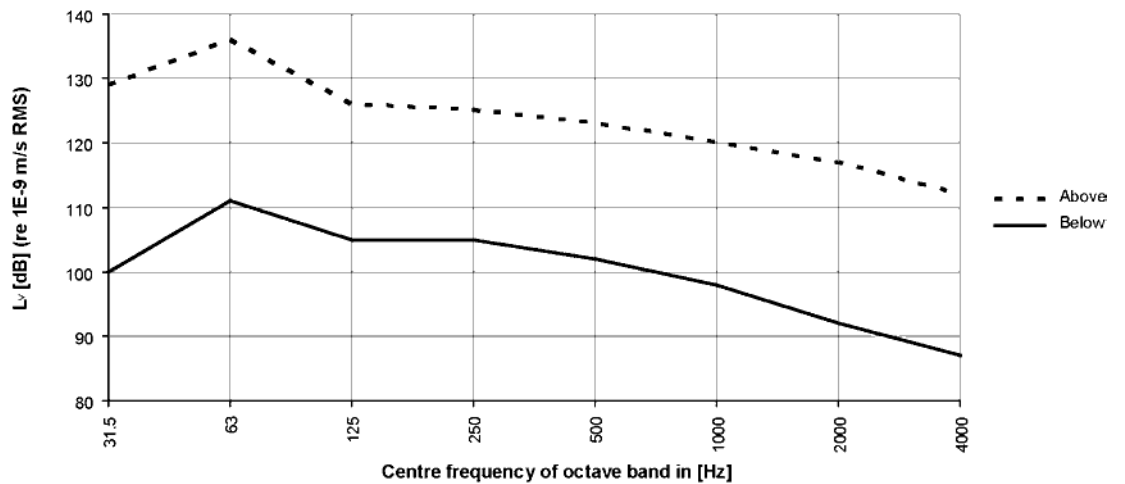

Fig 16-3 Generating sets, typical structure borne noise levels above and below resilient mounts (DBAB120103)

16.4 Air borne noise

The airborne noise of the engines is measured as sound power level based on ISO 9614-2. The results represent typical engine A-weighted sound power level at full load and nominal speed.

Table 16-5 W20 Engine A-weighted Sound Power Level in Octave Frequency Band [dB, ref. 1pW]

[Hz]	125	250	500	1000	2000	4000	8000	Total
8L	84	98	109	111	111	115	105	118
9L	97	106	110	113	113	116	111	120

Table 16-6 W20_1200rpm Engine A-weighted Sound Power Level in Octave Frequency Band [dB, ref. 1pW]

[Hz]	125	250	500	1000	2000	4000	8000	Total
6L	91	100	110	115	115	112	107	120
8L	86	99	109	114	113	115	106	120
9L	99	106	111	114	114	116	112	121

16.5 Exhaust noise

The results represent typical exhaust sound power level emitted from turbocharger outlet to free field at engine full load and nominal speed.

Table 16-7 W20 Free Field Exhaust Gas Sound Power Level in Octave Frequency Band [dB, ref. 1pW]

[Hz]	32	63	125	250	500	1000	2000	4000	Total
8L	135	141	143	135	137	122	118	112	146
9L	142	152	151	141	132	122	116	114	155

Table 16-8 W20_1200rpm Free Field Exhaust Gas Sound Power Level in Octave Frequency Band [dB, ref. 1pW]

[Hz]	32	63	125	250	500	1000	2000	4000	Total
6L	135	146	146	145	147	129	121	113	152
8L	135	142	143	136	139	122	118	112	147
9L	142	152	151	141	132	123	116	114	155

This page intentionally left blank

17. Power Transmission

17.1 Flexible coupling

The power transmission of propulsion engines is accomplished through a flexible coupling or a combined flexible coupling and clutch mounted on the flywheel. The crankshaft is equipped with an additional shield bearing at the flywheel end. Therefore also a rather heavy coupling can be mounted on the flywheel without intermediate bearings.

The type of flexible coupling to be used has to be decided separately in each case on the basis of the torsional vibration calculations.

In case of two bearing type generator installations a flexible coupling between the engine and the generator is required.

17.1.1 Connection to generator

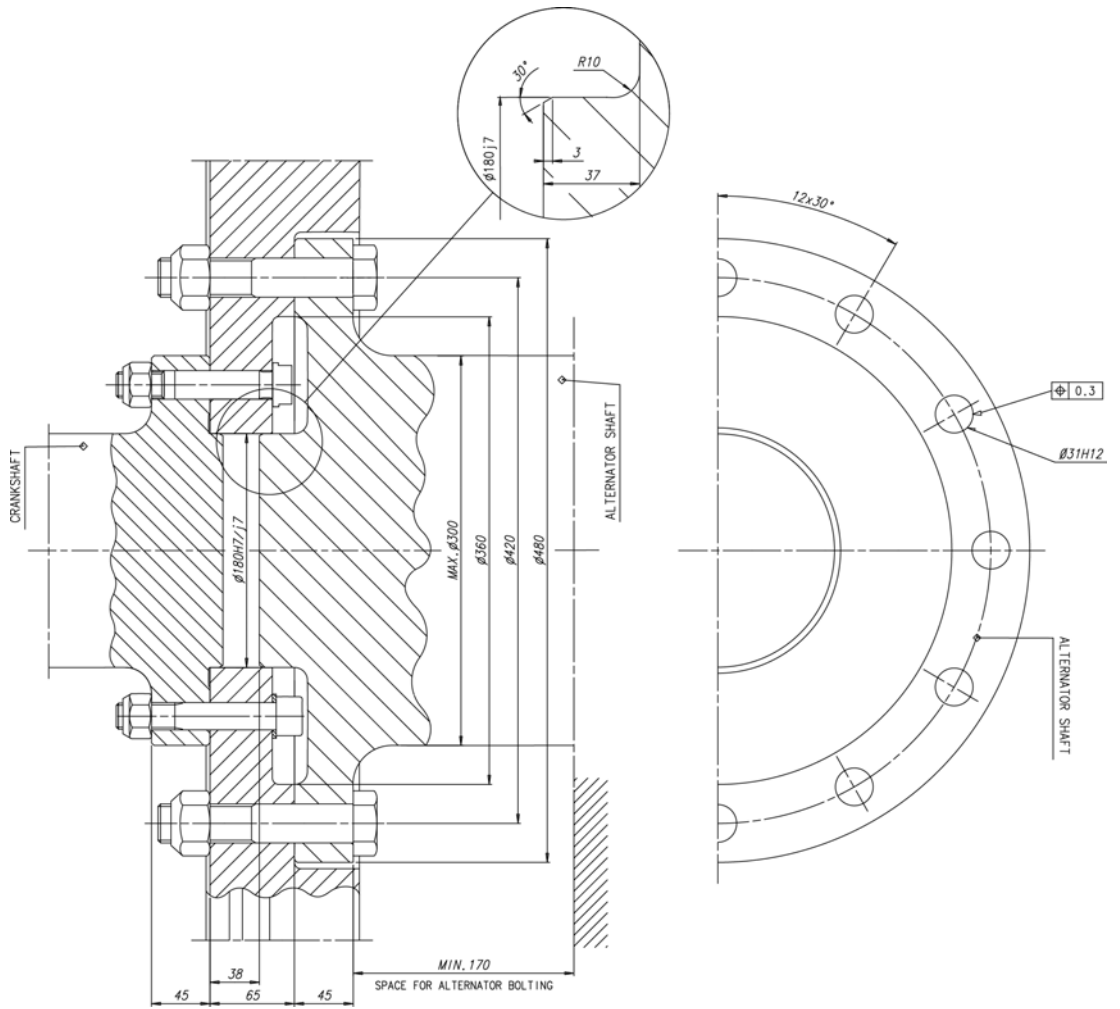

Fig 17-1 Connection engine/single bearing generator (V64L0071B)

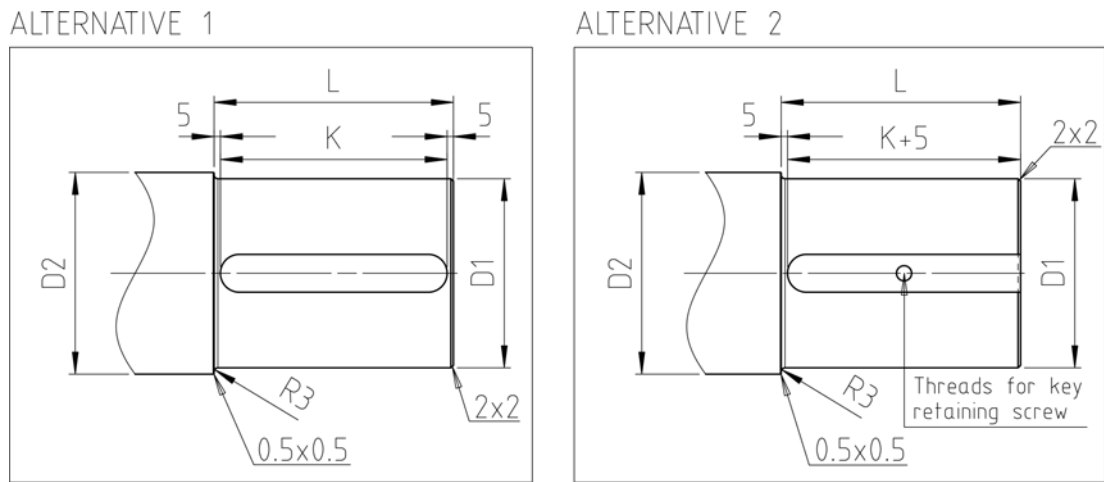

Fig 17-2 Connection engine/two-bearing generator (V64F0001C)

Engine	Dimensions [mm]			
	D ₁	L	K	min D
W 4L20	120	150	140	130
W 6L20	150	190	180	160
W 8L20	150	190	180	160
W 9L20	150	190	180	160

17.2 Clutch

In many installations the propeller shaft can be separated from the diesel engine using a clutch. The use of multiple plate hydraulically actuated clutches built into the reduction gear is recommended.

A clutch is required when two or more engines are connected to the same driven machinery such as a reduction gear.

To permit maintenance of a stopped engine clutches must be installed in twin screw vessels which can operate on one shaft line only.

17.3 Shaft locking device

A shaft locking device should also be fitted to be able to secure the propeller shaft in position so that wind milling is avoided. This is necessary because even an open hydraulic clutch can transmit some torque. Wind milling at a low propeller speed (<10 rpm) can due to poor lubrication cause excessive wear of the bearings.

The shaft locking device can be either a bracket and key or an easier to use brake disc with calipers. In both cases a stiff and strong support to the ship's construction must be provided.

To permit maintenance of a stopped engine clutches must be installed in twin screw vessels which can operate on one shaft line only. A shaft locking device should also be fitted to be able to secure the propeller shaft in position so that wind milling is avoided. This is necessary because even an open hydraulic clutch can transmit some torque. Wind milling at a low propeller speed (<10 rpm) can due to poor lubrication cause excessive wear of the bearings.

The shaft locking device can be either a bracket and key or an easier to use brake disc with calipers. In both cases a stiff and strong support to the ship's construction must be provided.

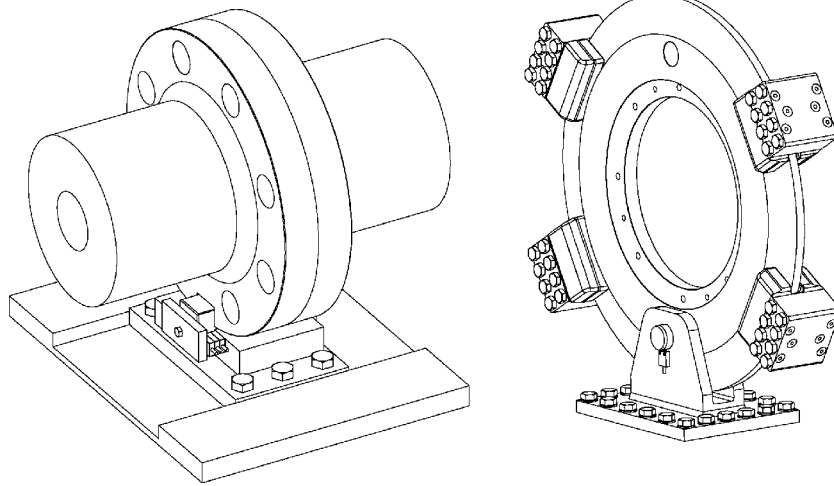

Fig 17-3 Shaft locking device and brake disc with calipers

17.4 Power-take-off from the free end

At the free end a shaft connection as a power take off can be provided. If required full output can be taken from the PTO shaft.

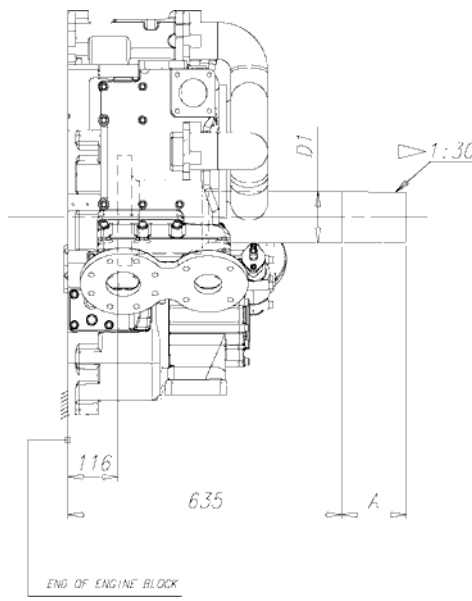

Fig 17-4 PTO alternative 1 (DAAE079074A)

Rating [kW]	Dimensions [mm]	
	D1	A
700 ¹⁾	80	105
2300 ¹⁾	120	150

Rating is dependent on coupling hub. Max. output may also be restricted due to max coupling weight 135 kg. 1320 kW always accepted.

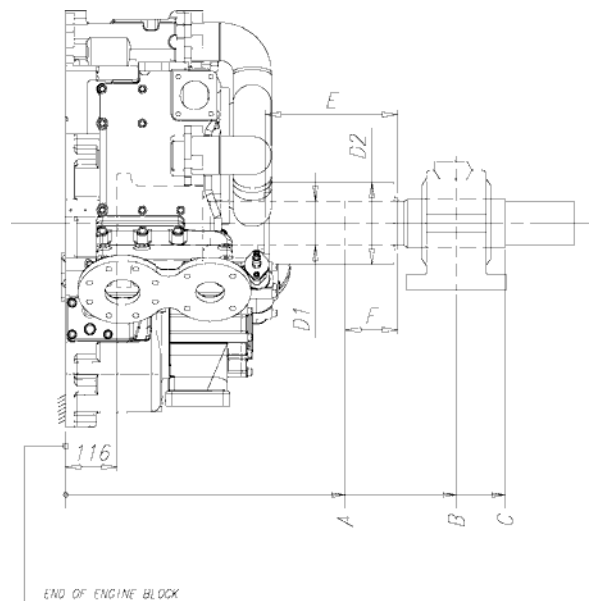

Fig 17-5 PTO alternative 2 (DAAE079045)

Rating [kW] ¹⁾	Dimensions [mm]						
	D1	D2	A	B	C	E	F
1700 ¹⁾	100	170	610	860	970	280	108
2200 ¹⁾	110	185	630	880	990	300	118

External support bearing is not possible for resiliently mounted engines.

¹⁾ PTO shaft design rating, engine output may be lower

17.5 Input data for torsional vibration calculations

A torsional vibration calculation is made for each installation. For this purpose exact data of all components included in the shaft system are required. See list below.

Installation

- Classification
- Ice class
- Operating modes

Reduction gear

A mass elastic diagram showing:

- All clutching possibilities
- Sense of rotation of all shafts
- Dimensions of all shafts
- Mass moment of inertia of all rotating parts including shafts and flanges
- Torsional stiffness of shafts between rotating masses
- Material of shafts including tensile strength and modulus of rigidity
- Gear ratios
- Drawing number of the diagram

Propeller and shafting

A mass-elastic diagram or propeller shaft drawing showing:

- Mass moment of inertia of all rotating parts including the rotating part of the OD-box, SKF couplings and rotating parts of the bearings
- Mass moment of inertia of the propeller at full/zero pitch in water
- Torsional stiffness or dimensions of the shaft
- Material of the shaft including tensile strength and modulus of rigidity
- Drawing number of the diagram or drawing

Main generator or shaft generator

A mass-elastic diagram or an generator shaft drawing showing:

- Generator output, speed and sense of rotation
- Mass moment of inertia of all rotating parts or a total inertia value of the rotor, including the shaft
- Torsional stiffness or dimensions of the shaft
- Material of the shaft including tensile strength and modulus of rigidity
- Drawing number of the diagram or drawing

Flexible coupling/clutch

If a certain make of flexible coupling has to be used, the following data of it must be informed:

- Mass moment of inertia of all parts of the coupling
- Number of flexible elements
- Linear, progressive or degressive torsional stiffness per element
- Dynamic magnification or relative damping
- Nominal torque, permissible vibratory torque and permissible power loss

- Drawing of the coupling showing make, type and drawing number

Operational data

- Operational profile (load distribution over time)
- Clutch-in speed
- Power distribution between the different users
- Power speed curve of the load

17.6 Turning gear

The engine can be turned with a manual ratchet tool after engaging a gear wheel on the flywheel gear rim. The ratchet tool is provided with the engine.

This page intentionally left blank

18. Engine Room Layout

18.1 Crankshaft distances

Minimum crankshaft distances have to be followed in order to provide sufficient space between engines for maintenance and operation.

18.1.1 Main engines

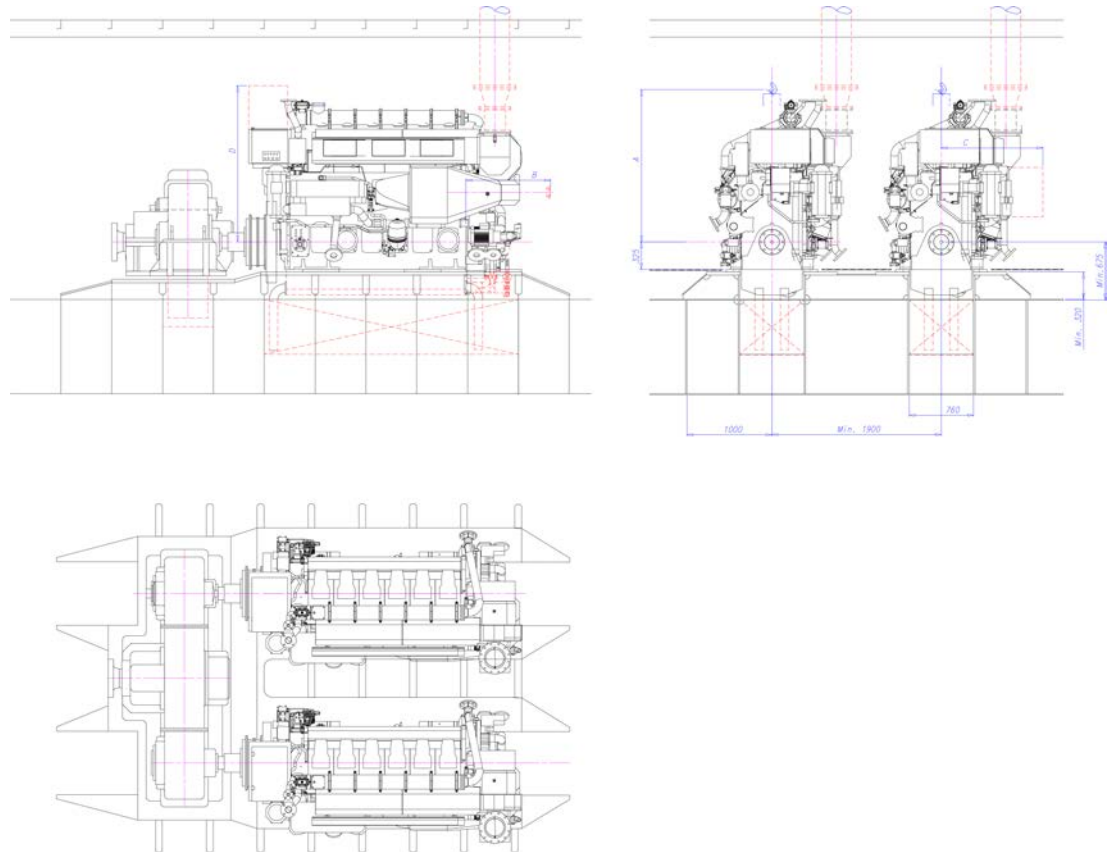

Fig 18-1 Crankshaft distances main engines (DAAF017589)

Engine	A	B	C	D
W 4L20 or W 6L20	1800	1000	1200	1845
W 8L20	1800	1300	1200	1845
W 9L20	1800	1300	1200	1845

All dimensions in mm.

A - Minimum height when removing a piston

- B - Camshaft overhaul distance
- C - Charge air cooler overhaul distance
- D - Space necessary for access to the connection box

18.1.2 Generating sets

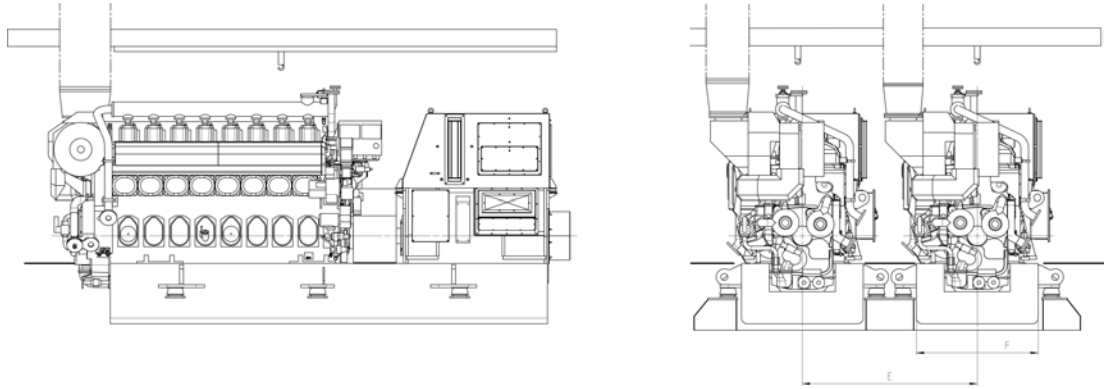

Fig 18-2 Crankshaft distances generating sets (DAAE007434D)

Table 18-1 Standard genset

Engine type	E*	F
W 4L20	1970 / 2040	1270 / 1420
W 6L20	1970 / 2040 / 2170	1270 / 1420 / 1570
W 8L20	2040 / 2170 / 2250	1420 / 1570 / 1700
W 9L20	2040 / 2200 / 2400	1420 / 1570 / 1700

Table 18-2 Double flexible installed genset

Engine type	E*	F
W 4L20	2450	1350
W 6L20	2450	1350
W 8L20	2450	1350
W 9L20	2450	1350

E = MIN. DISTANCE BETWEEN ENGINES DEPENDENT ON COMMON BASE PLATE

F = WIDTH OF THE COMMON BASE PLATE DEPENDENT ON WIDTH OF THE ALTERNATOR

* In case of extra wide lifting lugs needed, 230mm should be added to dimension E. Depending on final generator selection

* Dimension E should be checked at all times with each project specific configuration due to generator service space

All dimensions in mm.

18.2 Space requirements for maintenance

18.2.1 Working space reservation

It is recommended to reserve about one meter of free working space.

No obstructions should be built in way of:

- Crankcase and camshaft covers
- Camshaft withdrawal space
- Engine driven pump service space
- Charge air cooler withdrawal space
- Piston overhauling height
- Turbocharger maintenance space
- Electrical junction box door

Free route for hauling parts to and from engine to be foreseen.

See chapter "*Transport Dimensions and Weights*" for dimensions of maintenance items.

18.2.2 Lifting equipment

It is essential for efficient and safe working conditions that the lifting equipment are applicable for the job and they are correctly dimensioned and located.

The required engine room height depends on space reservation of the lifting equipment and also on the lifting and transportation arrangement. The minimum engine room height can be achieved if there is enough transversal and longitudinal space, so that there is no need to transport parts over insulation box or rocker covers.

Separate lifting arrangement for overhauling turbocharger is required (unless overhead travelling crane, which also covers the turbocharger is used). Turbocharger lifting arrangement is usually best handled with a chain block on a rail located above the turbocharger axis.

18.2.3 Maintenance platforms

In order to enable efficient maintenance work on the engine, it is advised to build the maintenance platforms on recommended elevations. The width of the platforms should be at minimum 800 mm to allow adequate working space. The surface of maintenance platforms should be of non-slippery material (grating or chequer plate).

NOTE



Working Platforms should be designed and positioned to prevent personnel slipping, tripping or falling on or between the walkways and the engine

18.3 Transportation and storage of spare parts and tools

Transportation arrangement from engine room to storage and workshop has to be prepared for heavy engine components. This can be done with several chain blocks on rails or alternatively utilising pallet truck or trolley. If transportation must be carried out using several lifting equipment, coverage areas of adjacent cranes should be as close as possible to each other.

Engine room maintenance hatch has to be large enough to allow transportation of main components to/from engine room.

It is recommended to store heavy engine components on slightly elevated adaptable surface e.g. wooden pallets. All engine spare parts should be protected from corrosion and excessive vibration.

On single main engine (SME) installations it is important to store heavy engine parts close to the engine to make overhaul as quick as possible in an emergency situation.

18.4 Required deck area for service work

During engine overhaul some deck area is required for cleaning and storing dismantled components. Size of the service area is dependent of the overhauling strategy chosen, e.g. one cylinder at a time, one bank at a time or the whole engine at a time. Service area should be plain steel deck dimensioned to carry the weight of engine parts.

18.4.1 Service space requirement

18.4.1.1 Service space for engines with turbocharger in driving end

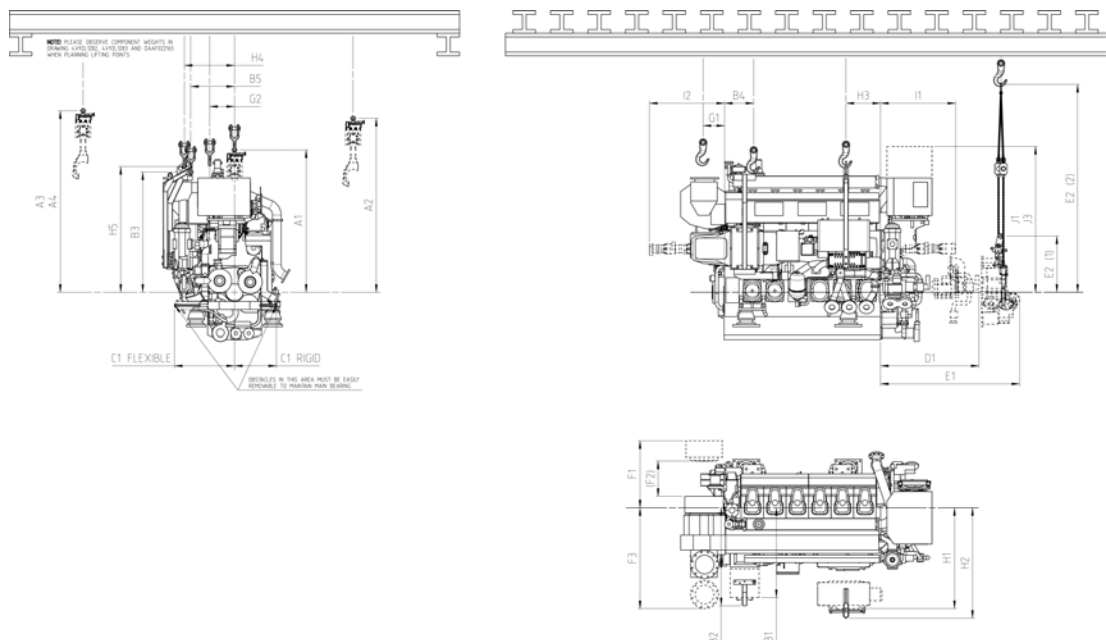

Fig 18-3 Service space for engines with turbocharger in driving end (V69C0301E)

Service spaces in mm		6L	8L	9L
A1	Height for overhauling piston and connecting rod	1800		
A2	Height for transporting piston and connecting rod freely over adjacent cylinder head covers	2300		
A3	Height for transporting piston and connecting rod freely over exhaust gas insulation box	2300	2400	2400
B1	Width for dismantling charge air cooler and air inlet box	1200		
B2	Width for dismantling charge air cooler and air inlet box sideways by using lifting tool	1310		
B3	Height of the lifting eye for the charge air cooler lifting tool	1600		
B4	Recommended lifting point for charge air cooler lifting tool	390		
B5	Recommended lifting point for charge air cooler lifting tool	585		

Service spaces in mm		6L	8L	9L
C1	Removal of main bearing side screw, flexible / rigid mounting	800 / 560		
D1	Distance needed for dismantling lubricating oil and water pumps	635		
E1	Distance needed for dismantling pump cover with fitted pumps	With PTO: lenght + 515 Without PTO: 650		
E2	Height of lifting eye for the pump cover with fitted pumps, with lifting tool 1/ alternative lifting tool 2	750 / 2770		
F1	The recommended axial clearance for dismantling and assembly of silencers	650	710	710
F2	Minimum axial clearance	100		
F3	Recommended distance for dismantling the gas outlet elbow	990	1170	1170
G1	Recommended lifting point for the turbocharger	300		
G2	Recommended lifting point sideways for the turbocharger	345		
H1	Width for dismantling lubricating oil module and/or plate cooler	1250		
H2	Width for dismantling lubricating oil module with lifting tool	1380		
H3	Recommended lifting point for dismantling lubricating oil module and/or plate cooler	445		
H4	Recommended lifting point sideways for dismantling lube oil module and/or plate cooler	1045		
H5	Height of lifting eye for dismantling lube oil module with lifting tool	1675		
I1	Camshaft overhaul distance (free end)	1000	1300	1300
I2	Camshaft overhaul distance (flywheel end)	1000	1300	1300
J3	Space necessary for access to connecting box	2150		

18.4.1.2 Service space for engines with turbocharger in free end

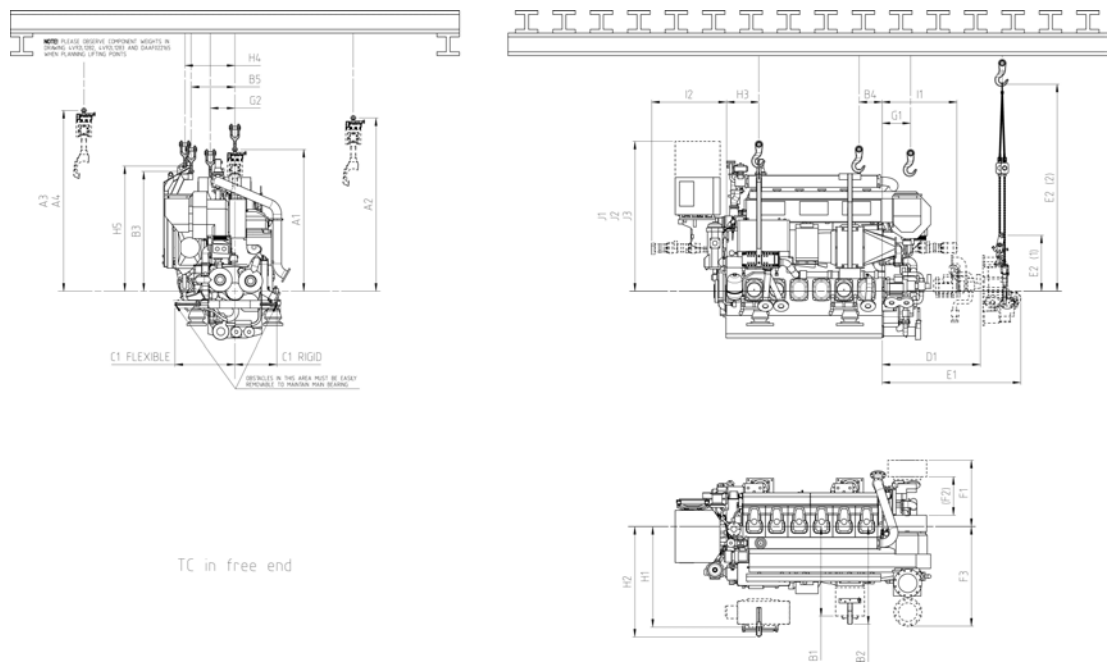

Fig 18-4 Service space for engines with turbocharger in free end (V69C0302F)

Service spaces in mm		4L	6L	8L	9L
A1	Height for overhauling piston and connecting rod	1800			
A2	Height for transporting piston and connecting rod freely over adjacent cylinder head covers	2300			
A3	Height for transporting piston and connecting rod freely over exhaust gas insulation box	2230	2300	2400	2400
A4	Height needed for transporting piston and connecting rod freely over 60°C exhaust gas insulation box (SOLAS)	-	-	-	2720
B1	Width for dismantling charge air cooler and air inlet box	1200			
B2	Width for dismantling charge air cooler and air inlet box sideways by using lifting tool	1310			
B3	Height of the lifting eye for the charge air cooler lifting tool	1600			
B4	Recommended lifting point for charge air cooler lifting tool	260	550		
B5	Recommended lifting point for charge air cooler lifting tool	585			
C1	Removal of main bearing side screw, flexible / rigid mounting	800 / 560			
D1	Distance needed for dismantling lubricating oil and water pumps	635			
E1	Distance needed for dismantling pump cover with fitted pumps	With PTO: length + 515 Without PTO: 650			
E2	Height of the lifting eye for the pump cover with fitted pumps, with lifting tool 1/ alternative lifting tool 2	750 / 2770			
F1	The recommended axial clearance for dismantling and assembly of silencers	590	650	750	750
F2	Minimum axial clearance	100			
F3	Recommended distance for dismantling the gas outlet elbow	890	990	1120	1120
G1	Recommended lifting point for the turbocharger	350			
G2	Recommended lifting point sideways for the turbocharger	320			
H1	Width for dismantling lubricating oil module and/or plate cooler	1250			
H2	Width for dismantling lubricating oil module with lifting tool	1480			
H3	Recommended lifting point for dismantling lubricating oil module and/or plate cooler	445			
H4	Recommended lifting point sideways for dismantling lube oil module and/or plate cooler	1045			
H5	Height of lifting eye for dismantling lube oil module with lifting tool	1675			
I1	Camshaft overhaul distance (free end)	700	1000	1300	1300
I2	Camshaft overhaul distance (flywheel end)	700	1000	1300	1300
J3	Space necessary for access to connecting box	2120			

18.4.1.3 Service space for generating sets

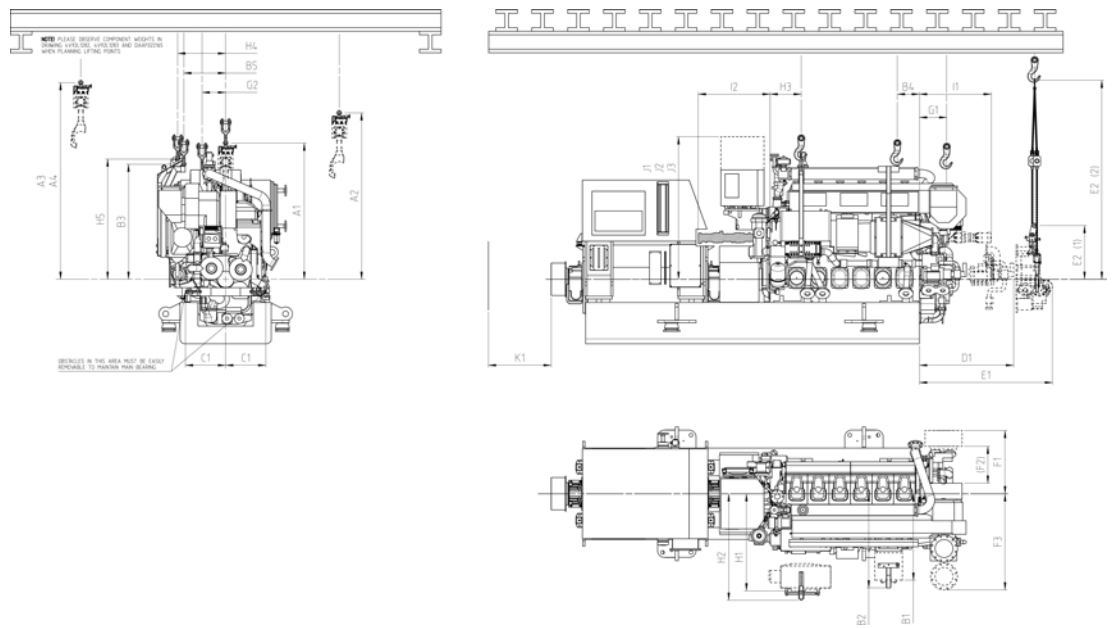

Fig 18-5 Service space for generating sets (DAAE006367E)

Service spaces in mm		4L	6L	8L	9L
A1	Height for overhauling piston and connecting rod	1800			
A2	Height for transporting piston and connecting rod freely over adjacent cylinder head covers	2300			
A3	Height for transporting piston and connecting rod freely over exhaust gas insulation box	2230	2300	2400	2400
A4	Height needed for transporting piston and connecting rod freely over 60°C exhaust gas insulation box (SOLAS)	-	-	-	2720
B1	Width for dismantling charge air cooler and air inlet box	1200			
B2	Width for dismantling charge air cooler and air inlet box side-ways by using lifting tool	1310			
B3	Height of the lifting eye for the charge air cooler lifting tool	1600			
B4	Recommended lifting point for charge air cooler lifting tool	260	550		
B5	Recommended lifting point for charge air cooler lifting tool	585			
C1	width for removing main bearing side screw	560			
D1	Distance needed for dismantling lubricating oil and water pumps	635			
E1	Distance needed for dismantling pump cover with fitted pumps	650			
E2	Height of the lifting eye for the pump cover with fitted pumps, with lifting tool 1/ alternative lifting tool 2	750 / 2770			
F1	The recommended axial clearance for dismantling and assembly of silencers	590	650	750	750
F2	Minimum axial clearance	100			
F3	Recommended distance for dismantling the gas outlet elbow	890	990	1120	1120
G1	Recommended lifting point for the turbocharger	350			
G2	Recommended lifting point sideways for the turbocharger	320			

Service spaces in mm		4L	6L	8L	9L
H1	Width for dismantling lubricating oil module and/or plate cooler	1250			
H2	Width for dismantling lubricating oil module with lifting tool	1480			
H3	Recommended lifting point for dismantling lubricating oil module and/or plate cooler	445			
H4	Recommended lifting point sideways for dismantling lube oil module and/or plate cooler	1045			
H5	Height of lifting eye for dismantling lube oil module with lifting tool	1670			
I1	Camshaft overhaul distance (free end)	700	1000	1300	1300
I2	Camshaft overhaul distance (flywheel end)	700	1000	1300	1300
J3	Space necessary for access to connecting box	2120			
K1	Service space for generator	500			

19. Transport Dimensions and Weights

19.1 Lifting of engines

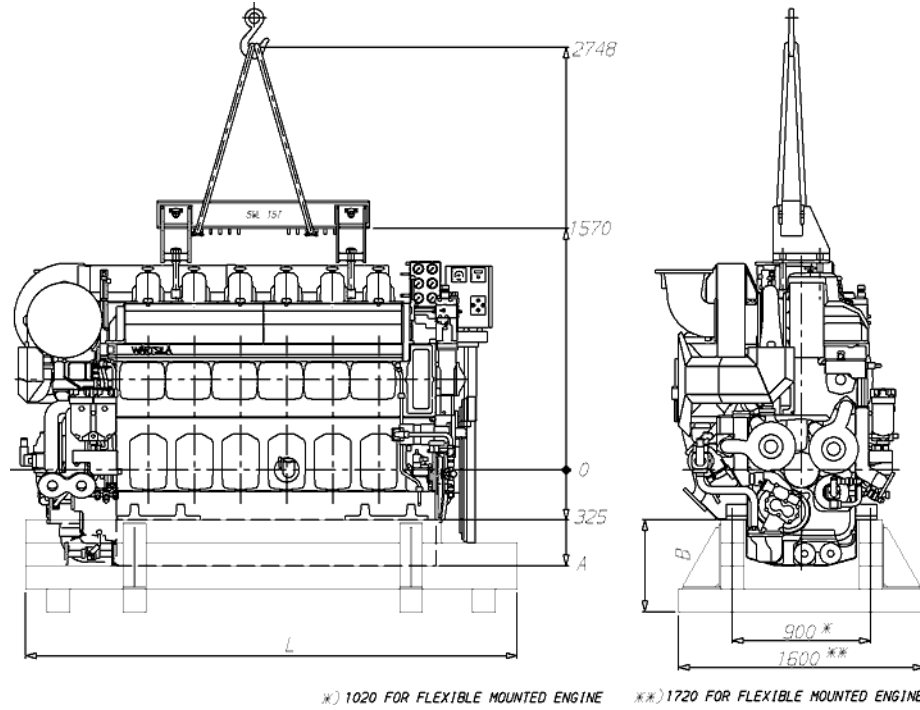
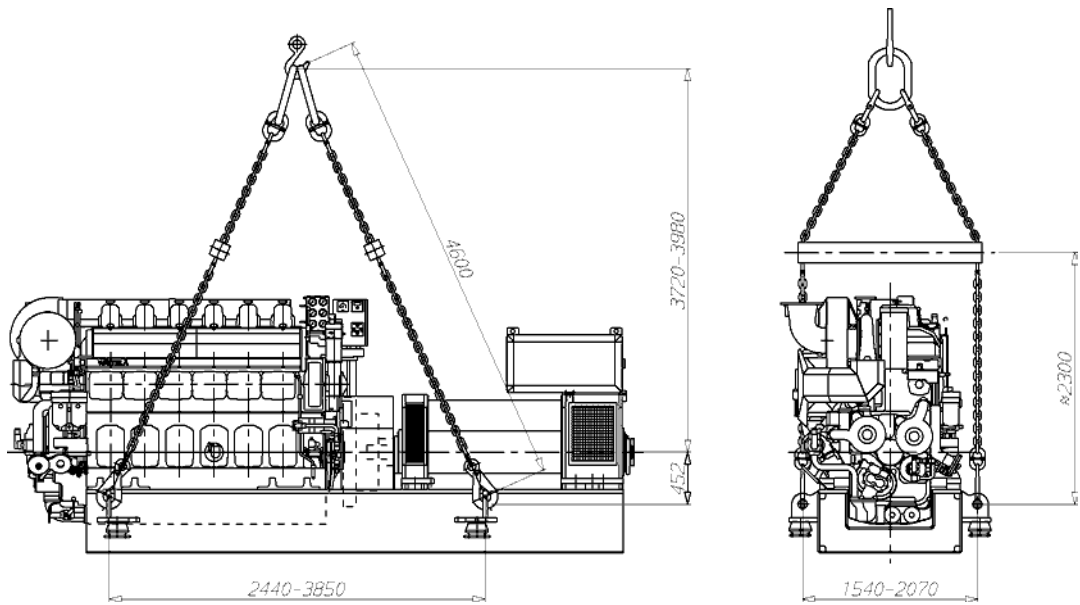

Fig 19-1 Lifting of main engines (V83D0285C)

Engine	L [mm]	Dry sump		Wet sump	
		A [mm]	B [mm]	A [mm]	B [mm]
W 4L20	2600	725	600	725	600
W 6L20	3200	624	600	824	675
W 8L20	3500	624	600	824	675
W 9L20	4100	624	600	824	675

**NOTE**

Maximum load 30 tonnes.

Fig 19-2 Lifting of generating sets (V83D0300D)

19.2 Engine components

19.2.1 Turbocharger and cooler inserts (DAAE031768C)

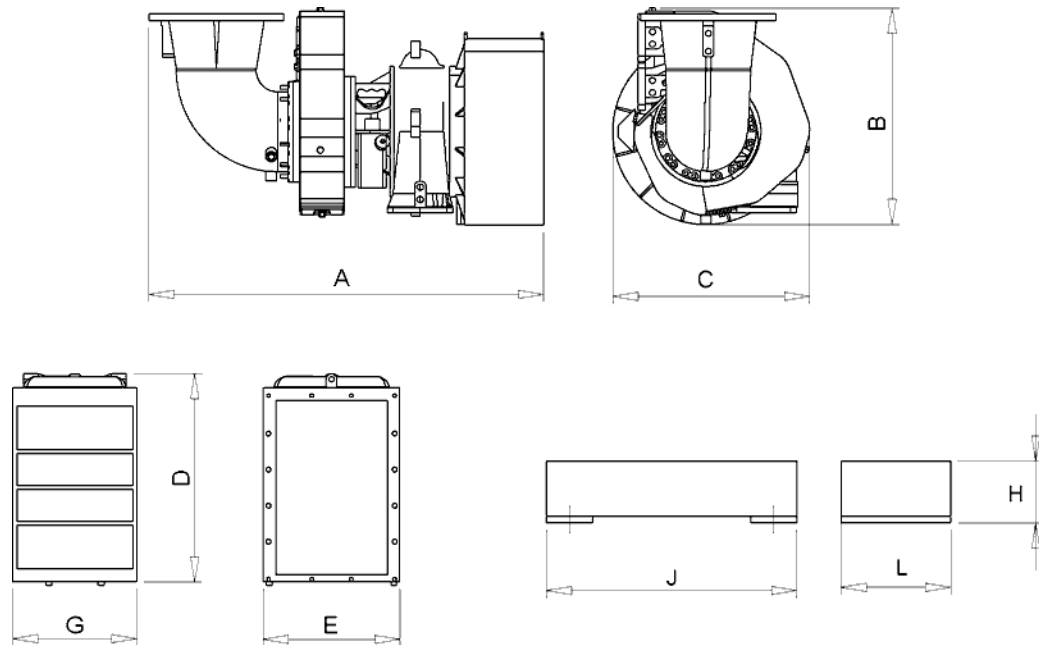

Engine	Turbocharger				Charge air cooler			
	A* [mm]	B* [mm]	C* [mm]	Weight* [kg]	D [mm]	E [mm]	G [mm]	Weight [kg] 900,1000 / 1200rpm
W4L20	936	536	490	160	568	340	285	126 / -
W6L20	1096	603	546	293	578	380	345	152 / 140
W8L20	1357	716	666	368	578	380	345	156 / 150
W9L20	1357	716	666	370	578	380	345	159 / 150

Engine	Lubricating oil cooler insert			
	H [mm]	J [mm]	L [mm]	Weight [kg]
W4L20	109	694	304	53
W6L20	150	694	304	64
W8L20	201	694	304	77
W9L20	238	694	304	87

NOTE



* Max. dimension/ weight.

19.2.2 Major spare parts (V92L1275A)

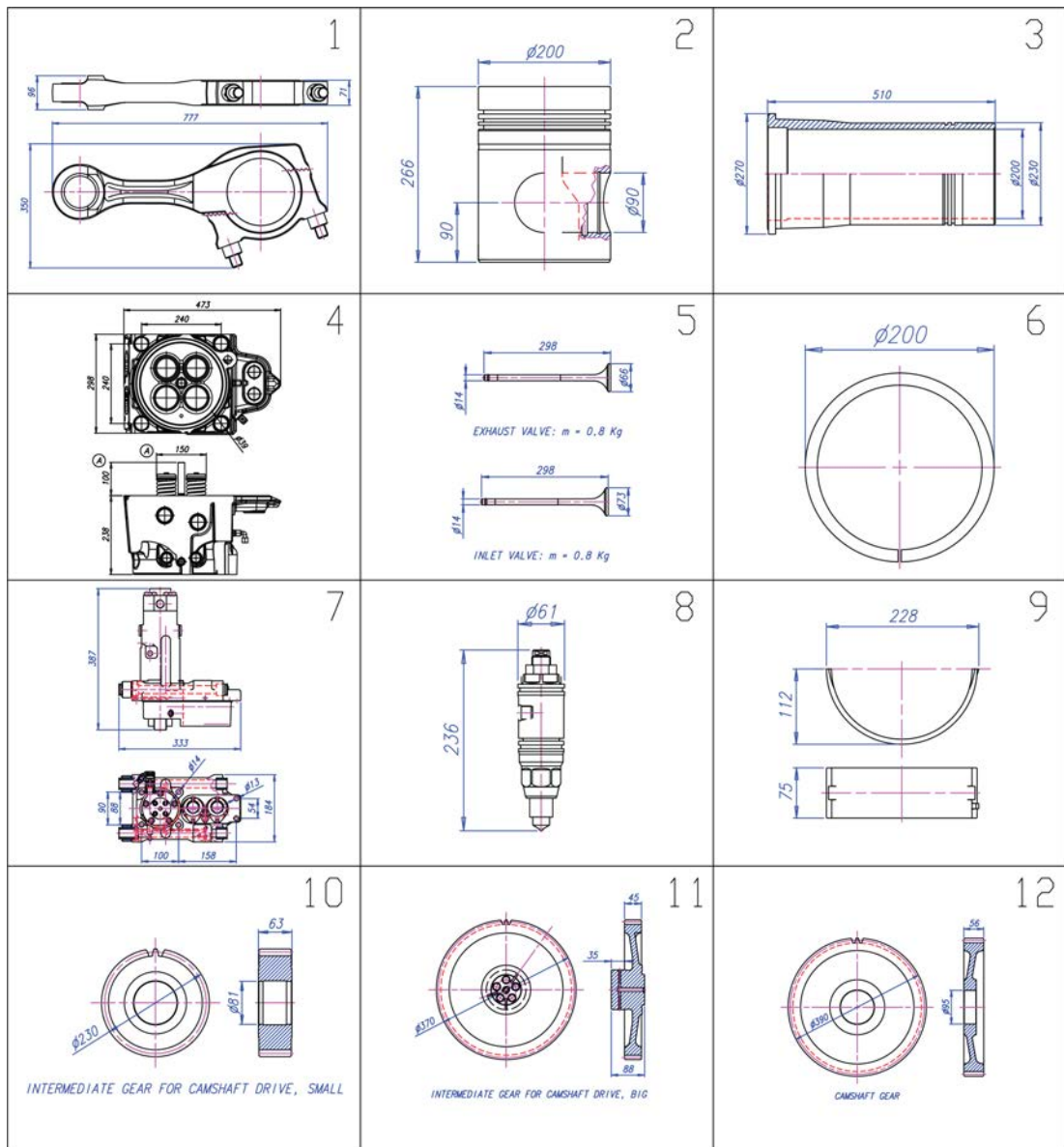

Item	Weight (kg)	Item	Weight (kg)
1 Connecting rod	39	7 Injection pump	27
2 Piston	21	8 Injection valve	3.2
3 Cylinder liner	41	9 Main bearing shell	1.4
4 Cylinder head	94	10 Smaller intermediate gear	11.4
5 Valve	0.8	11 Bigger intermediate gear	23.5
6 Piston ring	0.2	12 Camshaft drive gear	25

20. Product Guide Attachments

This and all other product guides can be accessed on the internet, at www.wartsila.com. Product guides are available both in web and PDF format. Engine outline drawings are available not only in 2D drawings (in PDF, DXF format), but also in 3D models in near future. Please consult your sales contact at Wärtsilä for more information.

Engine outline drawings are not available in the printed version of this product guide.

This page intentionally left blank

21. ANNEX

21.1 Unit conversion tables

The tables below will help you to convert units used in this product guide to other units. Where the conversion factor is not accurate a suitable number of decimals have been used.

Length conversion factors

Convert from	To	Multiply by
mm	in	0.0394
mm	ft	0.00328

Mass conversion factors

Convert from	To	Multiply by
kg	lb	2.205
kg	oz	35.274

Pressure conversion factors

Convert from	To	Multiply by
kPa	psi (lbf/in ²)	0.145
kPa	lbf/ft ²	20.885
kPa	inch H ₂ O	4.015
kPa	foot H ₂ O	0.335
kPa	mm H ₂ O	101.972
kPa	bar	0.01

Volume conversion factors

Convert from	To	Multiply by
m ³	in ³	61023.744
m ³	ft ³	35.315
m ³	Imperial gallon	219.969
m ³	US gallon	264.172
m ³	l (litre)	1000

Power conversion

Convert from	To	Multiply by
kW	hp (metric)	1.360
kW	US hp	1.341

Moment of inertia and torque conversion factors

Convert from	To	Multiply by
kgm ²	lbf ft ²	23.730
kNm	lbf ft	737.562

Fuel consumption conversion factors

Convert from	To	Multiply by
g/kWh	g/hph	0.736
g/kWh	lb/hph	0.00162

Flow conversion factors

Convert from	To	Multiply by
m ³ /h (liquid)	US gallon/min	4.403
m ³ /h (gas)	ft ³ /min	0.586

Temperature conversion factors

Convert from	To	Multiply by
°C	F	$F = 9/5 \text{ °C} + 32$
°C	K	$K = C + 273.15$

Density conversion factors

Convert from	To	Multiply by
kg/m ³	lb/US gallon	0.00834
kg/m ³	lb/Imperial gallon	0.01002
kg/m ³	lb/ft ³	0.0624

21.1.1 Prefix

Table 21-1 The most common prefix multipliers

Name	Symbol	Factor	Name	Symbol	Factor	Name	Symbol	Factor
tera	T	10 ¹²	kilo	k	10 ³	nano	n	10 ⁻⁹
giga	G	10 ⁹	milli	m	10 ⁻³			
mega	M	10 ⁶	micro	μ	10 ⁻⁶			

21.2 Collection of drawing symbols used in drawings

INTERNATIONAL STANDARD ISO 10628 and ISO 14617			INTERNATIONAL STANDARD ISO 10628 and ISO 14617			INTERNATIONAL STANDARD ISO 10628 and ISO 14617		
POS Reg. No.	SYMBOL	DESCRIPTION	POS Reg. No.	SYMBOL	DESCRIPTION	POS Reg. No.	SYMBOL	DESCRIPTION
1 2101		Valve (general)	10 X2113		Check valve globe type	17 X2131		Control valve with electric motor actuator
2 X8068		Valve, globe type	11 X8078		Swing check valve (Form 1)	18 X2103		Two-way valve with solenoid actuator
3 X8071		Valve, ball type	12 X8165		Swing check valve (Form 2)	19		Two-way valve with double-acting cylinder actuator (pneumatic)
4 X8074		Valve, gate type	13 X2124		Safety valve, spring loaded, globe type	20 X2104		Two-way valve with electric motor actuator
5 X8075		Valve, butterfly type (Form 1)	14 X1021		Manual operation of valve	21 X2101		Two-way valve with diaphragm actuator (pneumatic)
6 X8075		Valve, butterfly type (Form 2)	15 X2001		Weight-loaded safety valve detained in open position after operation	22		Two-way control valve with diaphragm actuator (pneumatic)
7 X8076		Valve, needle type	16 X2134		Float-operated control valve	23 X2002		Spring-loaded safety two-way valve with automatic return after operation
8 X8087		Valve, control type, continuously operated						
9 X8077		Check valve (general), (Two-way non-return valve; flow from left to right)						

Fig 21-1 List of symbols (DAAF406507 - 1)

INTERNATIONAL STANDARD ISO 10628 and ISO 14617			INTERNATIONAL STANDARD ISO 10628 and ISO 14617			INTERNATIONAL STANDARD ISO 10628 and ISO 14617		
POS Reg. No.	SYMBOL	DESCRIPTION	POS Reg. No.	SYMBOL	DESCRIPTION	POS Reg. No.	SYMBOL	DESCRIPTION
24		Manually operated control valve	33 X8070		Valve, three way globe type	40		Three-way control valve with diaphragm actuator
25 X2112		Combinated non-return valve and manually actuated stop valve. Flow from left to right	34 X8073		Valve, three way ball type	41		Self-operating pressure reducing three-way control valve
26		Spring-loaded non-return valve. Flow from left to right	35		Three-way control valve with electrical motor actuator	42		Self-operating thermostatic three-way control valve
27 X2133		Self-operating pressure reducing control valve	36 X2103		Three-way valve with solenoid actuator	43		Self-contained thermostat valve
28		Pressure control valve (spring loaded)	37 X2107		Three-way valve with double-acting cylinder actuator (pneumatic)	44 2102		Valve, angle type (general)
29		Pressure control valve (remote pressure sensing)	38		Three-way valve with electric motor actuator	45 X8069		Valve, angle globe type
30		Pneumatically actuated valve, spring-loaded cylinder actuator	39 X2102		Three-way valve with diaphragm actuator			
31		Quick-closing valve						
32 2103		Valve, three way type (general)						

Fig 21-2 List of symbols (DAAF406507 - 2)

INTERNATIONAL STANDARD ISO 10628 and ISO 14617			INTERNATIONAL STANDARD ISO 10628 and ISO 14617			INTERNATIONAL STANDARD ISO 10628 and ISO 14617		
POS Reg. No.	SYMBOL	DESCRIPTION	POS Reg. No.	SYMBOL	DESCRIPTION	POS Reg. No.	SYMBOL	DESCRIPTION
46 X8072		Valve, angle ball type	55 772		Orifice plate	62		Valve 2/2 Pneum/Pneum
47 X2125		Safety valve, spring loaded, globe angle type	56 X2182		Shuttle valve with "AND-function"	63		Valve 2/2 Pneum/Spring
48		Weight loaded angled valve detained in open position after operation	57		Valve 2/2 Pneum/Pneum	64		Valve 2/2 Solenoid/Spring
49		Spring-loaded safety angled valve with automatic return after operation	58		Valve 2/2 Pneum/Spring	65		Valve 2/2 Lever/Spring
50		Non-return angled two-way valve. Flow from left to right	59		Valve 2/2 Solenoid/Spring	66		Valve 2/2 Manual/Spring
51		Non-return angled two-way valve hand operating. Flow from left to right	60		Valve 2/2 Lever/Spring	67		Valve 2/2 Pneum/Pneum
52 2181		Self-operating release valve (steam trap)	61		Valve 2/2 Manual/Spring			
53 X2212		Adjustable restrictor (valve)						
54 2031		Restrictor						

Fig 21-3 List of symbols (DAAF406507 - 3)

INTERNATIONAL STANDARD ISO 10628 and ISO 14617			INTERNATIONAL STANDARD ISO 10628 and ISO 14617			INTERNATIONAL STANDARD ISO 10628 and ISO 14617		
POS Reg. No.	SYMBOL	DESCRIPTION	POS Reg. No.	SYMBOL	DESCRIPTION	POS Reg. No.	SYMBOL	DESCRIPTION
68		Valve 2/2 Pneum/Spring	77		Electrically driven compressor	84 X8079		Heat exchanger (general), condenser
69		Valve 2/2 Solenoid/Spring	78 2302		Compressor, vacuum pump (general)	85 X2674		Pneumatic-air lubricator
70		Valve 2/2 Lever/Spring	79 2301		Pump, liquid type (general)	86 X8111		Cooling tower, dry with induced draught
71		Valve 2/2 Manual/Spring	80 2401		Hydraulic pump	87 2521		Cooling tower (general) (Deerator)
72		Turbogenerator	81		Manual hydraulic pump	88 2040		Funnel
73		Turbogenerator with gear transmission	82 X2071		Boiler feedwater vessel with deerator	89		Trough or drip tray with drain funnel
74		Turbocharger	83 2501		Heating or cooling coil			
75 C0082		Electric motor (general)						
76		Electrically driven pump						

Fig 21-4 List of symbols (DAAF406507 - 4)

INTERNATIONAL STANDARD ISO 10628 and ISO 14617			INTERNATIONAL STANDARD ISO 10628 and ISO 14617			INTERNATIONAL STANDARD ISO 10628 and ISO 14617		
POS Reg. No.	SYMBOL	DESCRIPTION	POS Reg. No.	SYMBOL	DESCRIPTION	POS Reg. No.	SYMBOL	DESCRIPTION
90 517		Flanged dummy cover (Blind flange pair)	99 564		Quick-release coupling element of female type	106		Air vent + flame arrestor
91 511		Flanged connection	100 563		Quick-release coupling element of male type	107 2036		Flame arrestor
92 518		End cap	101 X411		Hose	108 X322		Pipeline with thermal insulation
93 514		Screwed joint	102 532		Expansion sleeve	109 X8174		Piping, heated or cooled and insulated
94 516		Reducer	103 533		Compensator (Expansion bellows)	110 X2619		High speed centrifuge (Separator)
95		Joint with change of pipe dimension, pipe reducer eccentric	104 2038		Siphon	111 X2614		Centrifuge with perforated shell (Centrifugal filter)
96 565		Quick-release coupling element which fits into another coupling element of the same type	105 2039		Vent (outlet to the atmosphere for steam/gas)			
97 567		Quick-release coupling element of female type with automatic closing when decoupled						
98 566		Quick-release coupling element of male type with automatic closing when decoupled						

Fig 21-5 List of symbols (DAAF406507 - 5)

INTERNATIONAL STANDARD ISO 10628 and ISO 14617			INTERNATIONAL STANDARD ISO 10628 and ISO 14617			INTERNATIONAL STANDARD ISO 10628 and ISO 14617		
POS Reg. No.	SYMBOL	DESCRIPTION	POS Reg. No.	SYMBOL	DESCRIPTION	POS Reg. No.	SYMBOL	DESCRIPTION
112 X8116		Liquid filter (general)	121 X8123		Screening device, sieve, strainer, general	128 X2069		Vessel with dished ends and heating / cooling jacket
113 X8117		Liquid filter, bag, candle or cartridge type	122 X8031		Gravity separator, settling chamber	129 2033		Silencer
114		Automatic filter with by-pass filter	123 X2618		Separator, cyclone type	130 2034		Viewing glass
115 X8019		Suction filter	124 X8090		Strainer	131		Receiver, pulse damper
116 X8119		Liquid rotary filter, drum or disc type	125 2073		Pressure vessel with diaphragm, for example expansion vessel	132		Indicating measuring instrument P = Pressure 106 T = Temperature 107 Y = Density 102 F = Flow rate 108
117		Duplex filter	126 2062		Pressure or vacuum vessel	133		Local instrument
118		Candle filter with rotating drum with by-pass	127 301		Tank, vessel			
119 X8122		Gas filter (general)						
120 X8022		Gas filter, bag, candle or cartridge type						

Fig 21-6 List of symbols (DAAF406507 - 6)

INTERNATIONAL STANDARD ISO 10628 and ISO 14617			INTERNATIONAL STANDARD ISO 10628 and ISO 14617			INTERNATIONAL STANDARD ISO 10628 and ISO 14617		
POS Reg. No.	SYMBOL	DESCRIPTION	POS Reg. No.	SYMBOL	DESCRIPTION	POS Reg. No.	SYMBOL	DESCRIPTION
134		Local panel	141 X1032		Automatic operation of valve with two stable positions open and close	148		
135		Signal to control board	142			149		
136		TI = Temperature indicator TE = Temperature sensor TEZ = Temperature sensor shut-down PI = Pressure indicator PS = Pressure switch PT = Pressure transmitter PSZ = Pressure switch shut-down FOIS = Differential pressure indicator and alarm LS = Level switch QS = Flow switch TSZ = Temperature switch	143			150		
137 X2122		Overflow safety valve	144			151		
138 X1048		Flow rate indication	145			152		
139 X1056		Recording of flow rate with summation of volume	146			153		
140 X1036		Automatic operation of valve with infinite number of stable positions	147					

Fig 21-7 List of symbols (DAAF406507 - 7)

Wärtsilä is a global leader in complete lifecycle power solutions for the marine and energy markets. By emphasising technological innovation and total efficiency, Wärtsilä maximises the environmental and economic performance of the vessels and power plants of its customers.

www.wartsila.com

