



Image for demonstration purposes

Generating Set
Base Frame - Diesel

GE.DZ.021/020.BF+011

1500 rpm - Trifase - 50Hz - 400V
 Multifunction panel without switching on board



Standard equipment

Exhaust

Exhaust manifold protection
 Silenced muffler -15dB(A)

Fuel Supply

Single wall daily tank with bunded base
 Automatic shutdown system for low fuel level
 Fuel gauge

Handling

Loadable side by side for truck transportation

Base Frame

Anti-vibrating mounting pads
 Anti pollution Bunded base

Engine

High coolant temperature and low oil pressure shutdown system
 External oil drain points
 Engine liquids (oil and antifreeze)
 Rotating parts protection

Alternator

AVR Automatic Voltage Regulator
 Impregnation for marine environment
 IP23

Panel & connection

Emergency Stop button
 Protection by controller
 Cable output from the bottom
 IP44 wiring
 Start-up battery (pre-charged)
 Grounding point

Documentation

CE conformity declaration
 User and Maintenance manual
 Wirings diagrams

Normatives

All Generating sets are compliant to CE Marking
 2014/30/UE Electromagnetic compatibility
 2000/14/CE Noise Emission for outdoor use
 Factory-designed systems built according to ISO 9001:2015
 CEI EN 60204-1:2018 - Electrical equipment of machines

Primary data

General Information

Speed	RPM	1500
Frequency	Hz	50
PRP	KVA	21
PRP - Prime power	KW	16,8
LTP - Standby power	KVA	22
LTP - Standby power	KW	17,6
Standard Voltage	V	400/230
Current	A	30,35
Voltage for current calculation	V	400
COSFI	0,8	0,8

General electrical protection

Rated current	A	63
Type		Magnetothermal switch on panel board
Poles	N	4P
Optional/notes		Opening coil
Protection device		Control module

Fuel Consumption

TYPE		Diesel
Standard Fuel Tank capacity	lt	90
Autonomy @ 75% load	h	22
Fuel consumption at 100% load	lt/h	5,5
Fuel consumption at 75% load	lt/h	4,1
Fuel consumption at 50% load	lt/h	3

General data

Rated capacity	Ah	1x70
Auxiliary Voltage	V	12
Exhaust gas temperature	°C	510
Exhaust gas flow	l/s	65,2
Combustion air flow	l/s	23,8
Cooling fan airflow	mc/s	0,5
Exhaust diameter	mm	50

Weight and Dimensions

Dimensions (L x W x H)	cm	148x88x122
Weight with liquids (excluding optionals and fuel)	Kg (+/-3%)	564

Engine

Factory		Deutz
Model		F3M 2011
Emissions stage		Stage 2
Speed governor		Mechanic
Cooling	<i>Tipo</i>	Oil
Active net power	<i>Kwm</i>	19
Nominal net power	<i>CV</i>	25,8
Cycle	<i>Tipo</i>	4 strokes
Injection	<i>Tipo</i>	Indirect
Aspiration	<i>Tipo</i>	Natural
Numbers of cylinders	<i>N</i>	3
Cylinders arrangement		L
Bore	<i>mm</i>	94
Stroke	<i>mm</i>	112
Total displacement	<i>lt</i>	2,331
Engine oil features		15W40-API CI-4/CH-4 ACEA E5-E7
Total oil capacity	<i>lt</i>	8,5
Total coolant capacity	<i>lt</i>	8,5
ISO 8528-5 class		G2

Alternator

*** May vary based on stock availability. However, a primary brand will be used.**

Factory		Stamford
Model		SOL2-G1
PRP continuous power	<i>KVA</i>	20
Voltage Regulator (voltage accuracy)	<i>+/- %</i>	1
Poles	<i>N°</i>	4
Phases	<i>N°</i>	3+N
Standard windings connection		Star Series
Stator/rotor impregnation		H (Outdoor Temp 40°C)
Efficiency	<i>%</i>	86,8
Engine coupling		Elastic disk
Short circuit current		>= 300% (3In)
Protection degree	<i>IP</i>	23
Cooling system		Self ventilating
Maxium overspeed	<i>rpm</i>	2250
Waveform distortion	<i>%</i>	<5
Exciter		Diode bridge

Standard operating environmental conditions

Ambient temperature	<i>°C</i>	25
Relative Humidity	<i>%</i>	30
Max altitude	<i>mt</i>	1000

Control Systems on board QLE-B-SC-3F-4P-63-01

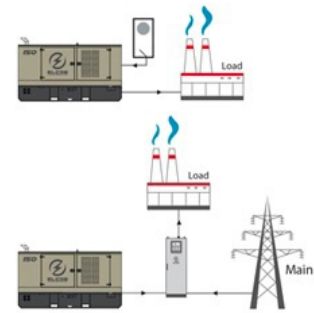

operating scheme - schema di funzionamento

QLE Multifunction panel without switching on board

The QLE command and control panel offers outstanding protection, monitoring and control for small and middle size generator sets. Elcos's control module MC2 Plus offers advanced features to meet the most demanding on-site application. Elcos's control module MC2 Plus is designed to offer an easy user interface. Variant without transfer switch. The panel directly manages the QLTS and QC panels. The output line is protected by a magnetothermic breaker with opening coil. The overload and short-circuit protection is managed by the control board.

Mechanical features

Protection degree	IP	55
-------------------	----	----

Battery charger

Model		ELCOS - CB1
Maximum output current	A	2,5
Output DC voltage (selectable)	V _{dc}	12-24
Input AC voltage (selectable)	V _{ac}	220-260
Frequency	Hz	50-60

Data Communication

Data connection port		RS-485
Communication protocol		Mod-bus RTU-8N1

Remotable functions in terminal box

GS start	Genset contactor close/open command (1)
Mains contactor close/open command (2)	Remote horn - DC output
Programmable output - Volt free output	

(1) Ready to load function (ARS mode without QC or QLTS panel)(1) Genset contactor open and close command (AMF mode with QC or QLTS panel)(2) Mains contactor open and close command (AMF mode with QC or QLTS panel)

Control Module



Model	MC2 Plus
Operating mode	AMF - ARS

Specifics

Applications

Emergency to the Mains
Stand-alone
Construction site/Rental
Self-production

ENGINE MEASURES

Fuel tank level %
Total run time
Battery voltage
Start-ups counter
Engine speed

ALTERNATOR MEASURES

Generator Voltage L1, L2, L3
Generator Voltage L1-N, L2-N, L3-N
Generator frequency
Generator current L1, L2, L3
Generator Apparent Power kVA
Generator Active Power kW

COMMUNICATION PORTS

Can-bus port
RS485 port with Mod-bus RTU communication
USB port for parameters saving and firmware update

EQUIPMENT

Microprocessor Logic
Back-lit display
Programmable from display
16 event log
Icons management
STOP button
START button
TEST button
Reset alarm button
Alarm mute button

PRE-ALARMS/ ALARMS

Common Alarm
Fuel reserve (pre-alarm)
Low fuel level (alarm)
Charge alternator failed (dinamo)
Low oil pressure (alarm)
Oil sensor failed (alarm)
High coolant temperature (alarm)
Battery undervoltage
Battery overvoltage
GS failure to start
GS failure to stop
Can-bus Failure
No Can-bus communication
Genset overload L1, L2, L3 phases
Genset short circuit
Genset overvoltage
Genset undervoltage
Genset high frequency
Genset low frequency
overspeed
Earth fault (alarm)
Maintenance request
Emergency button pressed
Remote emergency active
Genset negative phase sequence

VISUALIZATIONS ON CONTROL

MODULE/DISPLAY

Pre-alarms
Alarms
Engine measures
Alternator measures
Operating mode
Genset status
Genset contactor status
Glow plugs status

CONTROL MODULE FUNCTIONS

Remote Start and Stop
Manual Start and stop
Emergency stop button on panel board
Remote emergency stop
Remote test on load
Scheduled start-ups
MODBUS commands (Start, Stop, Reset, Test)

(2) Present according to the engine equipment and to the ECU type (ECU - Canbus)

(3) Present only with the residual current device mounted on genset board

(5) Present with special function activated

OPTIONAL

Fuel Supply



O.G-ACO-AT-C3V-01

External fuel tank connections with 3-way valve for supply from internal or external tank (10/100 kVA)



O.G-ACO-AT-CI-01

External tank connections for supply only from external tank (g without tank) GE 10/100



O.G-ACO-BT-P1700-400

400 Lt Oversized Fuel Tank on board for BF/PRO (10/20 kVA), (Increased weight and size)

Electrical on board



O.Q-QLE-K-DIF-M3

Adjustable differential protection only for MC2-PLUS controller for Gen Sets 10/500 kVA (+011 variant)



O.Q-QLE-QBM-COM-AMF25

Additional price for QBM COMAP AMF25 panel replacing the standard QLE-A.



O.Q-QLE-QBM-DSE-7320

Additional price for QBM DSE7320 panel replacing the standard QLE-A.



O.Q-QLE-QPE-MC4

Additional price for QPE-C panel with MC4 replacing the standard QLE-A.



O.Q-QPE-SAS-02

Auto Start-Stop at load request (QPE, QLE panels)

Engine



O.G-MOT-K-40C-01

Engine liquids suitable for -40°C ambient temperature for Gen Sets 10/40 kVA



O.G-MOT-PO-01

Oil change pump for Gen Sets 10/100 kVA



O.G-MOT-SC-AC-EL-01

Engine pre-heater 230V with thermostat on board for Gen Sets 10/100 kVA (BF/PRO/SS/RB)



O.G-MOT-SC-AC-EL-02

Super hot engine heater 230V with thermostat on board for Gen Sets 10/100 kVA



O.G-MOT-SE-PO-LR

Oil pressure level and engine temperature sensors (from 10 to 100kVA)

ATS Panels



QC1.0060A

Separate ATS panel, 4P - 60A contactors (40 kVA 400V - 30 kVA 230V) Dim. 60 x 25 x 80 cm - 47 kg. (ex QC1.040)

QLTS.060A

Wall-mounted ATS switching panel 60A 4P (40 kVA 400V - 20 kVA 230V) Dim. 40 x 16 x 40 cm - 12 kg.

 **Exhaust**

O.G-SCA-KS-50

Exhaust flex pipe for drainage (length 3 mt.)

O.G-SCA-MR-02

Residential muffler -35 dBA (10/20 kVA)

O.G-SCA-PF-01

Spark arrester for Gen Sets 10/40 kVA

PRP

Engines of this rating provide unlimited hours of usage in a variable load application. The average load factor should not exceed 70% of the engine's prime power rating with a maximum number of 500 operational hours at 100% prime power rating. An overload capability of 10% is available, however, is limited to a period of 1 in every 12 hours

LTP

Limited-time running power is defined as the maximum power available, under the agreed operating conditions, for which the generating set is capable of delivering for up to 500h of operation per year with the maintenance intervals. The overload is not allowed.

Sheet:	PRO1700.BF	OPEN FRAME	Exhaust side:	-	Type:	STANDARD	Rev:	01	Last Update:	15-04-2022	Page 1/2
--------	------------	------------	---------------	---	-------	----------	------	----	--------------	------------	----------

OVERALL DIMENSIONS [mm]

REAR VIEW

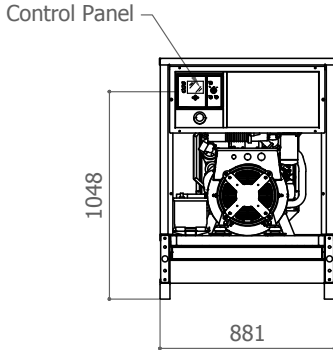

LEFT SIDE VIEW

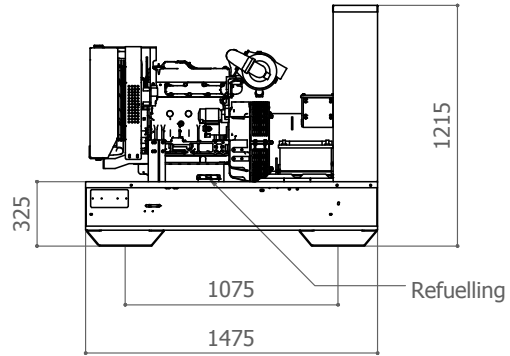

FRONT VIEW

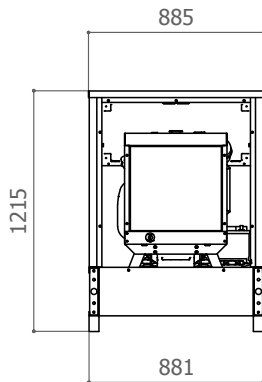

RIGHT SIDE VIEW

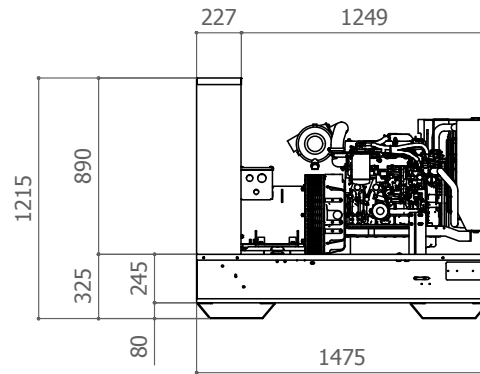

TOP VIEW

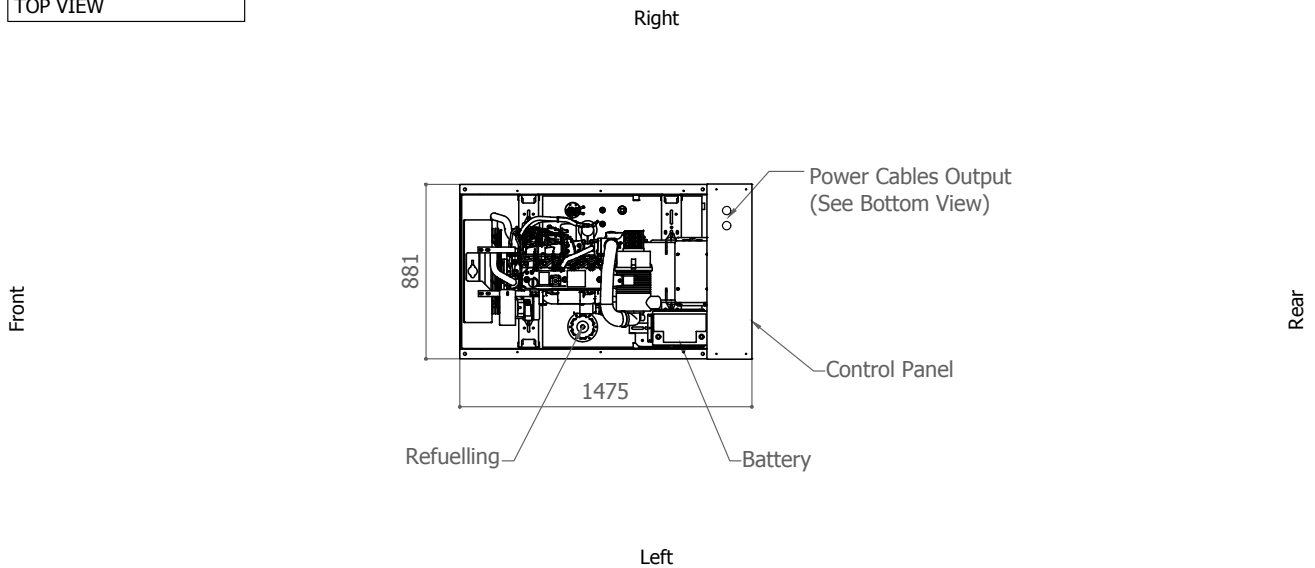

IMPORTANT:

- 1) Form and dimension refer to the generating set on catalogue
- 2) Form and dimension are subject to change in order to update or improve the products
- 3) This document can not be copied or transmitted without ELCOS S.r.l. approval

Sheet:	PRO1700.BF	OPEN FRAME	Exhaust side:	-	Type:	STANDARD	Rev:	01	Last Update:	15-04-2022	Page 2/2
--------	------------	------------	---------------	---	-------	----------	------	----	--------------	------------	----------

BOTTOM VIEW

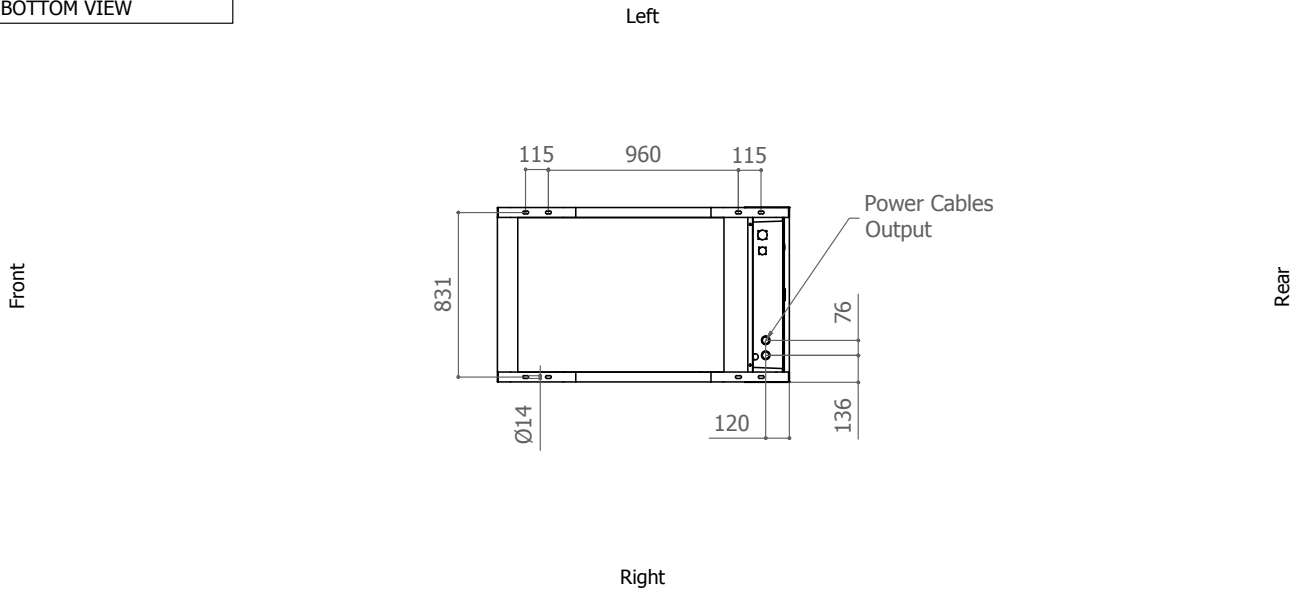

3D VIEW

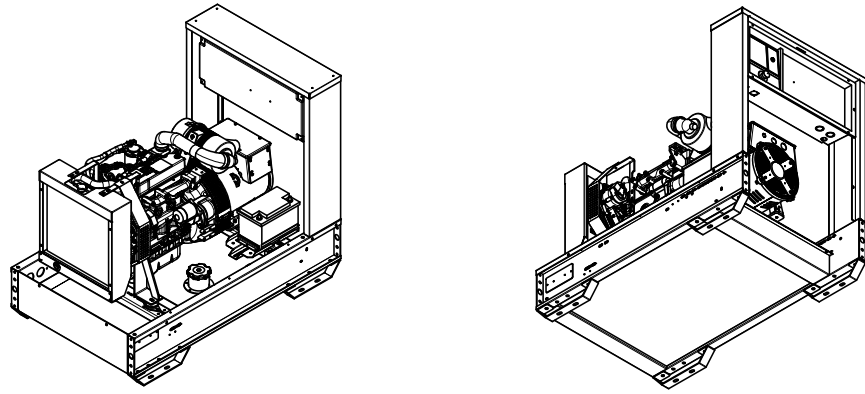

VENTILATION OF THE ROOM

The windows area in the generating set room needs to be (recommended):
 Aspiration: 0.26 m2
 Expulsion: 0.21m2
ATTENTION: for a correct ventilation the expulsion air and the exhaust gas needs to be conveyed in the open-air

- IMPORTANT:**
- 1) Form and dimension refer to the generating set on catalogue
 - 2) Form and dimension are subject to change in order to update or improve the products
 - 3) This document can not be copied or trasmitted without ELCOS S.r.l. approval

Data and technical specifications are subject to change in order to update or improve the products